

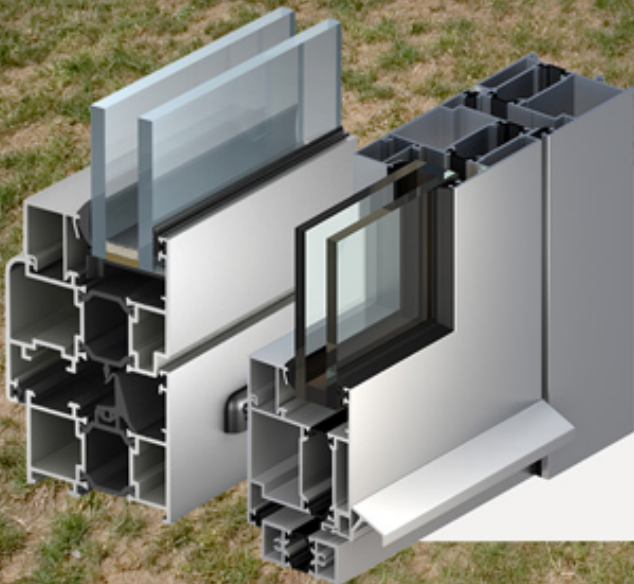

W62

**THERMALLY BROKEN
WINDOWS
& DOORS**





Key Features

- W62 system is a high thermal performance, architectural window and door system
- Various width sight lines
- Glazing choice from 5/8" to 1 9/16"
- Thermally broken components ensure high thermal performance
- Designed for integration with high performance curtain wall system F50
- Return panels and variable angles available
- Premium window and door hardware
- Tested to latest high performance air, water, structural and thermal standards
- Fixed, project in, tilt and turn, hopper windows
- Swing in, swing out single and double doors
- Over 200 colors available including 22 anodized finishes+ 2 wood grain patterns
- Moisture management system
- Simple and proven Eurogrove window solution

Optional Features

- Tilt and slide hardware
- Automatic saddle
- Plastic adaptor for easy flashing installation
- Shaped operable windows
- Dual color extrusions
- Multi point locks for entrance doors

Product Applications

- Ideal for commercial and residential applications where high thermal performance is desired
- Ideal for storefronts

COLOR AND FINISH GROUPS

NOTE – All RAL Colors from RAL K7 CLASSIC color chart <http://www.ralcolor.com/>
Please request a sample of a specific color from PGA for accurate color pick up.
PGA takes no responsibility for any color deviation from given reference because the colors of finished products depend solely on the coating components supplied by third parties. PGA products are painted with Swiss made coating powders by IGP.

0 Mill finish

1 All RAL K7 CLASSIC colors and Anodic: A00 – Clear, A01 – Light Bronze, A03 – Bronze, A05 – Black, A06 – Beige, A07 – Brown

2 Anodic: A20 – Champagne, A21 – 10K Gold, A22 – 14K Gold, A40-Light Copper, A41-Copper. Powder coated: RAL 1026, 1035, 1036, 2005, 2007, 2013, 3024, 3026, 3032, 3033, 4011, 4012, 5025, 5026, 6035, 6036, 6038, 7048, 8029, 9022, 9023

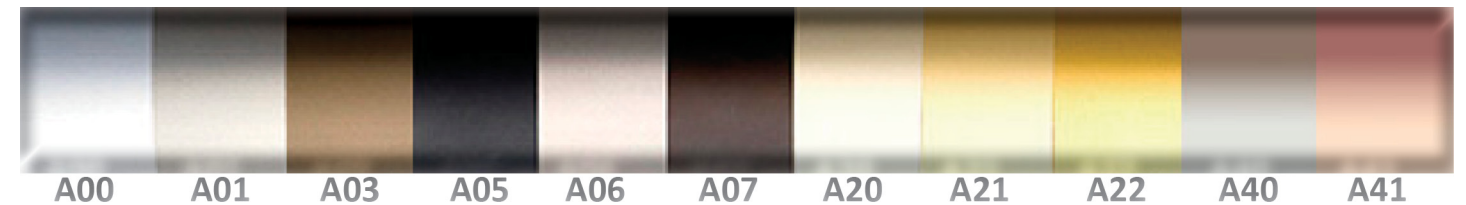

THE SAMPLES PRESENTED ON THIS PAGE ARE TO SERVE AS A REFERENCE STANDARD TO IDENTIFY THE COLOR SELECTED BY THE SPECIFIER. THE APPEARANCE OF AN ANODIZED OR POWDER COATED FINISH IS INFLUENCED BY MORE THAN DEPTH OF COLOR. OTHER FACTORS INCLUDE ALLOY, TEMPER, GLOSS AND SURFACE STRUCTURE. PROGRADE DISCLAIMS ANY RESPONSIBILITY OR LIABILITY AND MAKES NO WARRANTIES EXPRESS OR IMPLIED OF ANY KIND IN CONNECTION WITH THE MATERIAL AND INFORMATION CONTAINED HEREIN.

HOW TO USE THIS CATALOG

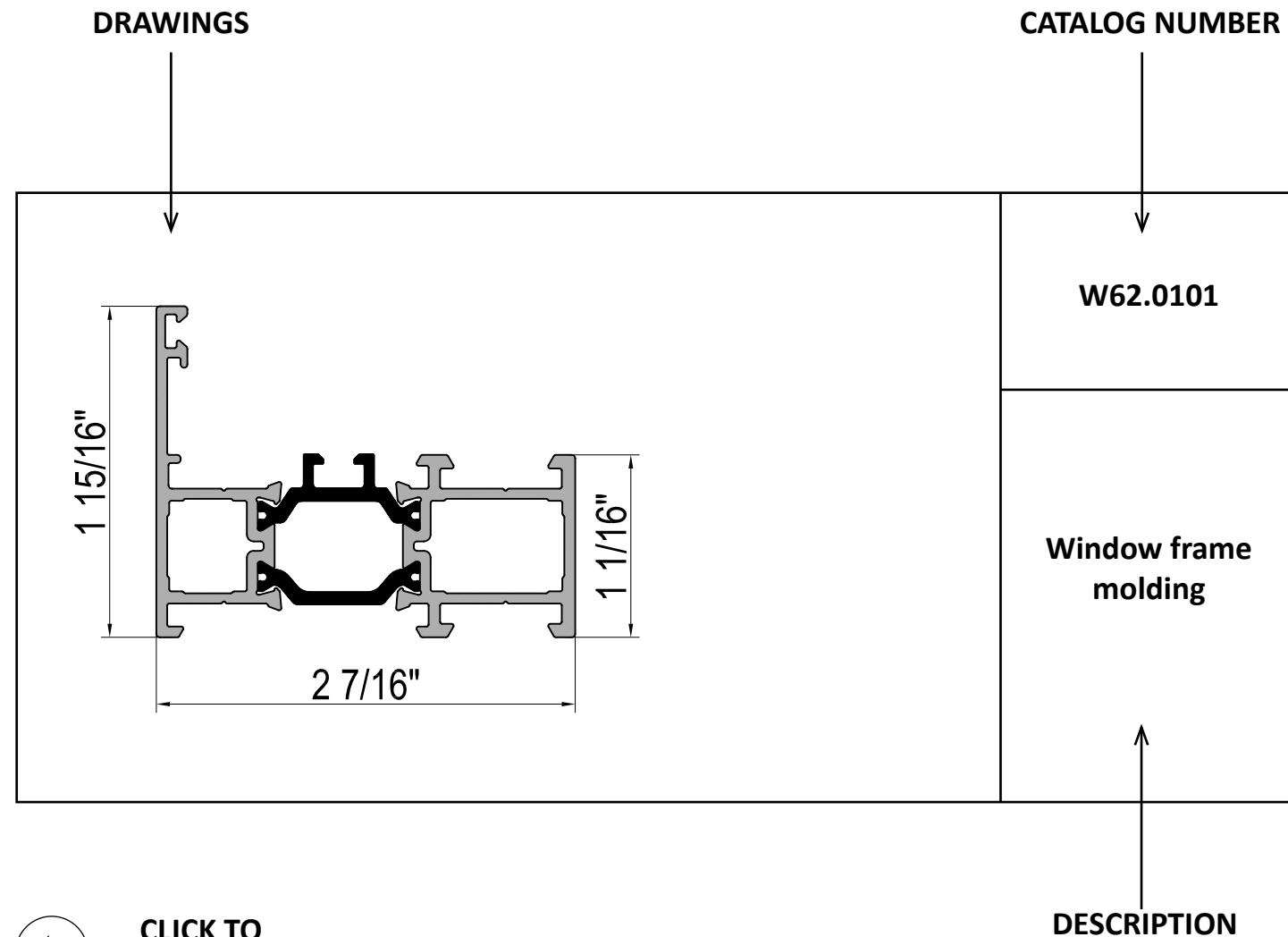

CLICK TO GO BACK



CLICK TO SEE SECTION

1

LIMITED WARRANTY

This is to certify that PROFESSIONAL GRADE ALUMINUM, CORP (PGA) warrants to its dealers, customers and all subsequent purchasers and owners of the project incorporating PGA products, subject to every term, condition and limitation stated herein, that the products supplied by PGA shall be free from material defect in materials and workmanship for a period of one (1) year from the date of substantial completion of the project, provided however, that the limited warranty period shall begin in no event later than three (3) months from the date of shipment. This limited warranty ("Limited Warranty") applies only if PGA'S products are installed and maintained according to PGA'S recommended practices and installation instructions, and only if PGA is notified in writing within thirty (30) days after such defect either (i) appears or (ii) should have been discovered after the exercise of reasonable diligence. Failure of the claiming party to notify PGA within such period shall automatically relieve PGA of any and all responsibility and/or liability under this Limited Warranty.

THE WARRANTIES SET FORTH IN THIS LIMITED WARRANTY AND REMEDY ARE IN LIEU OF ALL OTHER REPRESENTATIONS, WARRANTIES OR OTHER AGREEMENTS, EXPRESSOR IMPLIED, STATUTORY OR OTHERWISE, WHICH ARE HEREBY DISCLAIMED, INCLUDING, BUT NOT LIMITED TO, ANY IMPLIED WARRANTY OR CONDITION OF MERCHANTABILITY OR FITNESS FOR A PARTICULAR PURPOSE.

This Limited Warranty does not cover, and PGA hereby disclaims all liability for the installation of PGA products, any particular application or selection of the product for any particular project or design, any parts, gaskets, glazing materials, components or sealants of other manufacturers used with PGA products, or any lack of performance of PGA'S products attributable to such items. This Limited Warranty also does not cover, and PGA hereby disclaims all liability for, any product which has been subject to abuse, alteration, neglect, misuse, abnormal use, accident, fire, war, flood, earthquakes, acts of God, or to which parts, not supplied by PGA have been added, or to defects caused by depreciation or normal wear. All decisions regarding the

existence of defects in material and workmanship and the occurrence of any of the matters described in the preceding paragraphs or affecting this Limited Warranty shall be made by PGA and shall be final and binding upon all parties.

The sole and exclusive remedy with respect to this Limited Warranty or with respect to any other claim relating to defect or any other condition or use of the products supplied by PGA, however caused, and whether such claim is based upon breach of representation, warranty, condition, contract (fundamental or otherwise), tort (including negligence), strict liability or any other theory is limited to, at PGA'S option, repair or replacement of such products or repayment by PGA of the purchase price paid for it. The remedy with respect to claims made relating to PGA fenestration and door products excludes the replacement of glass, gaskets, hardware, immediate framing, temporary enclosures or any related labor or installation costs. In no event does PGA'S warranty cover the cost of labor or sundry materials required to remove and/or replace any defective product.

The products repaired, replaced or otherwise restored shall be warranted to the same extent and to the expiration date from the original date of shipment, and this Limited Warranty shall not be deemed to have been extended from the date of such warranty work. At no time does this Limited Warranty confer upon the claiming party or any other party the right to proceed with repair, replacement or restoration, without the written notice and agreement by a duly authorized officer of PGA. Any such work undertaken by the claiming party or any other party shall be for the claiming party's own account and shall result in this Limited Warranty becoming null and void.

PGA'S AGGREGATE TOTAL CUMULATIVE LIABILITY UNDER THIS LIMITED WARRANTY IS LIMITED TO THE DOLLAR AMOUNT OF THE PURCHASER'S ORIGINAL PAYMENT MADE TO PGA FOR PRODUCT FURNISHED BY PGA. IN CONSIDERATION OF THIS LIMITED WARRANTY, PGA SHALL NOT BE LIABLE FOR SPECIAL DIRECT, INDIRECT, INCIDENTAL OR CONSEQUENTIAL DAMAGES OF ANY KIND, INCLUDING BUT NOT LIMITED TO LOSS OF USE, LOSS OF PROFITS OR GOODWILL, DAMAGES FOR NEGLIGENCE IN THE MANUFACTURE, DESIGN OR INSTALLATION OF THE PRODUCT, OR OTHER COMMERCIAL LOSS OR INJURY.

This is the only warranty made in connection with the sale and distribution of the PGA products. No representative, dealer or any other person is authorized to make or makes any warranty, representation or promise with respect to the PGA products. No terms or conditions other than those stated herein, and no agreement or understanding, oral or written, in any way purporting to modify this warranty shall be binding on PGA unless made in writing and signed by a duly authorized officer of PGA.

Laws and building and safety codes governing the design and use of glaze entrance, window and curtain wall products vary widely. PGA does not control the selection of product configurations, operating hardware or glazing materials, and assumes no responsibility therefor.

OTHER TERMS AND CONDITIONS

DETERMINATION OF PRICE: Prices shown do not include Provincial Sales Tax or Goods & Services Tax or any other tax or government charge upon the production, sale or shipment of material which is effective within the life of the sales contract, all of which will be paid by the customer. All prices are subject to change without notice, and are not guaranteed against change. Inventory adjustments will not be made. Stenographic and clerical errors made by PGA on an acknowledgement or invoice shall be subject to correction.

NOTE: In the event that a discrepancy arises between the index and the body of the price catalog, the information contained in the body of the catalog will take precedence.

PRICE PROTECTION: In the event of a price decrease, unshipped orders, with the exception of special sales contracts covered by a lot or job estimates, will be invoiced at the new and lower prices. In the event of a price increase, orders on hand will be invoiced at the prices in effect when the orders were received, provided, however, those shipments are made at PGA'S convenience thereafter. PGA quotations on specific jobs made in writing by PGA are valid (or firm) for thirty (30) days.

ACCEPTANCE OF ORDERS: All orders are subject to approval and acceptance by a duly authorized representative of PGA.

The acceptance of orders constitutes a complete and binding contract which cannot be modified or canceled without written consent of both parties, except that all orders are accepted subject to delays caused by strikes, fires or any other causes (including those set out in the section "Force Majeure" below) beyond the control of PGA. All orders are accepted subject to governmental regulation on material usage, whenever applicable.

MINIMUM ORDER SIZE: Will depend on product and minimal quantity will be advised at the time of quotation.

PAYMENT: PGA stated payment terms are COD, unless otherwise approved in writing by a duly authorized representative of PGA. Early payment discounts are available. Please contact PGA for additional information.

CREDIT CARD PAYMENT (U.S. Customers Only): PGA will accept credit card payments. Credit Card invoices are paid in advance upon acceptance of invoice. Early payment discounts are available with credit card payments. Please contact PGA for additional information.

FREIGHT CHARGES AND RISK OF LOSS: Unless stated otherwise, all items are shipped F.O.B. PGA manufacturing facility.

CLAIMS: No claims due to errors, shortages or rejection because of defects or defective materials ascertainable on visual inspection will be considered unless reported to PGA within ten (10) days after receipt of shipment. Claims for damages resulting from delays or use of defective materials will not be honored.

DELIVERY: Orders should include complete shipping instructions. PGA reserves the right to ship as it deems advisable unless specific instructions are given. PGA will use

reasonable efforts to meet delivery dates but such dates are deemed approximate and PGA shall be allowed a reasonable variance from all such dates.

FORCE MAJEURE: PGA shall not be liable for delays or inability to perform due to strikes, labor disputes, lockouts, fire, flood, war, declared or undeclared, insurrections, riots, acts of God, embargoes by foreign nations, inability to obtain or unusual delay in obtaining materials, shortages of power needed to operate PGA facilities, governmental regulations or priorities, or any other cause beyond the control of PGA. In case of any delays in receipt or shortages of materials or shortages of power needed to operate PGA facilities, PGA reserves the right in its sole discretion to determine the assignment of materials, and the order of priority in filling orders. PGA also reserves the right in its sole discretion to cancel order by written notice in the event PGA believes that by reason of the foregoing it will not be able to meet the scheduled completion date.

INDEMNIFICATION: Customer is solely responsible for proper selection and installation of PGA products as well as the incorporation of PGA products into other products (if this is applicable). Customer agrees that it will use PGA products only for their intended uses and according to specifications and limitations established by PGA from time to time. Customer shall indemnify and hold PGA harmless from and against any and all damages arising out of or relating to improper selection, application, use or incorporation of products or abuse of products.

Laws and building and safety codes governing the design and use of glazed entrance, window and curtain wall products vary widely. PGA does not control the selection of product configurations, operating hardware or gazing materials, and assumes no responsibility therefor. It is the responsibility of the customer to determine at the time of order entry or revision, whether PGA material and products meet any federal, state, provincial and /or local law interpretation and regulations, including those relating to building construction, safety and to the Americans with Disabilities Act of 1990 and any other similar federal, state, provincial or local statutes.

ORDER CANCELLATION AND CHANGE CHARGES: In the event a customer changes an order or cancels or partially cancels an order that has already been accepted by PGA, PGA may assess a charge to the customer for costs incurred in performance of that portion of the order that has been changed or cancelled up to and until the time PGA receives notice of the change or cancellation.

Customer orders for special materials (those not described in the effective price book), or for products fabricated specifically to customer's dimensions or other specifications, or where special materials or services are procured by PGA for use on customer's order, or where drafting or take-off services have been performed, will be subject to charges for cancellation or change for those costs incurred in performance of that portion of the order that has been cancelled or changed up to and until the time PGA receives notice of the change or cancellation.

BALANCE DUE MATERIALS: Any portion of an order not included in an original shipment because of shortage of stock or other cause beyond PGA'S control will be invoiced at the same price and on the same terms as if included in the original shipment.

INSTALLATION: PGA hereby disclaims all liability for, and is not responsible or liable for, any damages or costs that may result from improper installation of its products. It is the responsibility of the customer purchasing a PGA product to ensure that the PGA product is installed properly and in accordance with PGA'S printed instructions. This responsibility is retained by customer even though the product may be resold for installation by a third party. PGA will not be liable for damages and costs that result from improper installation of PGA products, regardless of who actually performs the installation.

SAMPLES: Samples are available at cost (net). Standard samples are shipped from PGA's headquarters located at: **701 39TH Street Brooklyn, NY 11232.**

SPECIAL LENGTH CHARGES: For special length painted material requirements, consult with a PGA officer for pricing.

DOORS AND WINDOWS: PGA offers furnished to order products as well as a full range of components for doors and windows. Please contact PGA for a quote for finished product as well as assembly components.

HARDWARE: PGA uses only premium European hardware by DR. HAHN, FAPIM, SAVIO, ICSA, GIESSE. PGA normally doesn't install custom hardware, however depending on quantity this might be applicable to some orders. Please contact PGA for more information. Please contact PGA for more information.

EQUIPMENT AND TOOLS: Any equipment or tools for aluminum profiles processing manufactured by third parties and supplied by PGA are covered by respective manufacturer's warranty.

SHOP DRAWINGS: PGA products may be detailed by PGA to confirm specifications. In such cases, drawings will be submitted to the customer for approval. PGA will fabricate in accordance with dimensions and specifications shown on the customer approved drawings but will take no responsibility for failure of the customer to check drawings against job site conditions or for any other purpose. Special entrances cannot be scheduled for production until the approved detail, with the customer's signature, has been received, and all special hardware is in PGA'S possession. Changes made to any drawing after approval of details by customer may involve additional charges on the order.

GOVERNING LAW: The sale of PGA products hereunder with shipping addresses located in the United States shall be governed by the laws of New York State, excluding its laws related to choice or conflicts of law.

ILLUSTRATIONS: The illustrations within this catalog are for part identification only, and do not indicate size or proportions by comparison.

ENTIRE AGREEMENT: The Limited Warranty and Remedy and Other Terms and Conditions set forth the entire agreement between the customer and PGA relating to the sale of PGA'S products to customer.

FREIGHT CLAIM PROCEDURE GUIDE

INTRODUCTION: PGA strives to ship its product on safe, cost-effective carriers who understand the challenges of handling architectural aluminum products. Due to the typical order size of our shipments, much of our product ships via the LTL or Less-than-Truckload system. Although our order sizes warrant LTL shipping, our product's dimensions and finishes do not. PGA ships its product under FOB Origin freight terms. The transfer of ownership of the freight takes place at the origin (shipping point or PGA facility). Based upon those shipping terms, the freight is owned by the customer while it is in transit from PGA to its destination, regardless of freight payment terms (Prepaid or Collect). PGA makes every effort possible to assist with loss and damage freight claims for our customers, but it is the responsibility of freight owner to file any freight claims that occur while it is in transit. The following information is provided to assist our customers with the freight claims process.

LESS-THAN-TRUCKLOAD DEFINED: Less-than-Truckload carriage is characterized as multiple shipments consolidated into a single system that will be sorted and transported through a terminal network and relay points for delivery to multiple destinations. These establishments are generally characterized by the following network activities: local pickup, local terminal operations (sorting), line-haul (terminal to terminal), destination terminal operations (sorting), and local delivery. Freight can experience the sorting or cross-docking process at several terminal locations prior to reaching its destination terminal. The majority of freight damage occurs in this multiple-handling process. A Less-than-Truckload shipment is one which does not completely fill a truck or which weighs less than the weight required for the application of a full truckload freight rate. The historical definition for LTL freight is shipments under 10,000 pounds and not exceeding 28 linear feet of a trailer, but would differ from carrier to carrier.

LESS-THAN TRUCKLOAD PRICING: Generally, LTL freight rates are dependent upon weight, distance, freight classification and freight discounts. LTL carriers classify freight based upon the guidelines of the National Motor Freight Traffic Association (NMFTA).

The Classification is a system that catalogues and equitably groups all commodities moving in commerce into 18 classes (classes 50 through 500) according to their "transportability," as reflected by the four composite transportation characteristics prescribed by the ICC and the Department of Transportation's Surface Transportation Board. These characteristics are as follows: 1) density; 2) stow ability; 3) ease or difficulty in handling; and 4) liability. These freight classes establish equitable relationships between commodities and allow for fair pricing guidelines. The volume of freight a shipper has to offer affects price discounts as well. PGA has freight rate contracts with many carriers, and we apply that discount to your shipment when possible. PGA'S stock lengths fall under the Aluminum group. The classification of our 22'-4" aluminum extrusions falls under Aluminum: Lineal Shapes or Molding with a NMFC freight class of 60. Our assembled doors and windows ship under a NMFC freight class of 100 and our unassembled door frames ship under a NMFC freight class of 100. Our hardware and rubber weather strip/gasket both fall under a NMFC freight class of 70.

RECEIPT OF FREIGHT: It is extremely important that you take the time to receive your shipment properly. You should be receiving a PGA Packing List with each shipment. The Packing List allows you to effectively check your material into your facility, as it is unloaded. Visually inspect the condition of the freight while it is on the trailer. Any noticeable packaging damage should be addressed with the carrier's agent or driver and noted on the Bills of Lading (or Delivery Receipt) signed by both you and the driver. It is highly recommended that each and every customer invest in a digital camera to take pictures of the damage while it is still on the carrier's trailer. Photographs of the freight's condition immediately upon arrival to your facility greatly enhance the validity of the claim and expedite the process.

Following the visual inspection of the freight on the trailer, unload the freight. Prior to the driver leaving the dock, check your shipment carefully to see that it is in good order and all accounted for. Check for signs of damage that were concealed while on the carrier's trailer. Under NMFC rules, officially you do not have the right to open the packaging prior to signing for the freight (Delivery Receipt). It has not officially been

released to you. Some carriers may use this against you when filing a claim. So with the driver present and with his consent, open and inspect any damaged packaging and check for concealed damage to the material. You may wish to call the carrier terminal prior to doing this to get official direction in this inspection process. Write a precise description of the missing or damaged freight on both the carrier's copy and your copy of the Delivery Receipt. Based upon the PGA'S terms of sale, the customer owns the freight while it is in transit. A carrier's driver may suggest that you simply refuse the shipment if it contains damage. Based on the freight terms, you own this material, and refusing it will cause more complications between you and the carrier. Do not refuse a PGA shipment due to the FOB terms of sale, otherwise the carrier will be calling you with regard to additional handling and service fees.

SHIPMENT SHORTAGE/LOSS: If you feel part of your shipment is missing, verify the quantities against what is indicated on your Delivery Receipt and Packing List. Write a precise description of the shortage on both your copy and the carrier's copy, signed by both you and the driver. Make sure to have the following information available for the call:

- Freight Bill Number
- Billing Date on the Delivery Receipt
- Name of the Shipper
- Name of the Consignee
- Number of total pieces and missing pieces
- Weight of the shipment
- Delivery Date
- Precise description of the missing items
- Any part number, box number, or serial number listed on the missing piece(s)
- Any additional information to assist the carrier in locating the material (size, shape, color, etc)

VISIBLE DAMAGE: If the packaging of your shipment contains visible damage, take pictures and ask driver to make note of damaged packaging. Ask the driver to inspect

the material with you as you open the packaging. Again, write a precise description of the damaged freight on both the carrier's copy and your copy of the Delivery Receipt.

CONCEALED DAMAGE: If later you determine that there was freight damage to your material, report it to the carrier by calling them immediately. Reporting freight damage must be done within fifteen (15) days, but doing so immediately will reduce the impression that you caused the damage while the material was in your possession. Ask for an inspection of the material by a representative of the carrier. While you wait for an inspection, make every attempt to leave the material as it was when you first discovered the concealed damage or loss. A representative of the carrier will discuss the damage and loss with you over the phone and determine whether or not a formal inspection and written report will be required. An inspector may be dispatched to your facility, or the inspection will be waived and you may be asked to do an inspection yourself. Keep a written statement documenting the inspection. Many carriers have a Waiver of Inspection that allows you to document your own inspection of the material. It is not a claim form, and should not be considered acceptance of a claim.

CLAIM DEFINED: A claim is a written demand for payment by the owner of a shipment to the carrier for loss or damage occurring during transit. A carrier is required to acknowledge a claim within thirty (30) days. A claim and its supporting documentation is required to be filed within nine (9) months of delivery or expected delivery. According to the NMFC, all submitted claims must be acknowledged by the carrier with thirty (30) days. They must rule (pay, refuse to pay, or pending) on a claim within one hundred and twenty (120) days. If pending, they must provide an update every sixty (60) days regarding the status of the claim and the reason for failure to resolve claim. Most claims are settled (not necessarily paid) within 30 days.

CLAIMS PROCESSING: Lost or damaged material occurs during the shipping process. Carriers are responsible for any lost or damaged goods that arrive at your facility, and claims obviously affect the financial well being of the carrier. They have highly trained

claims processors that know the ins and outs of freight damage loopholes. Carriers will make every effort possible to create a basis to deny a freight claim. Claim forms can be found on carrier websites. Carriers can also send you a blank claim form via facsimile. A specific form is not mandatory. Either way, the following information must accompany the freight claim:

- The Vendor invoice for the goods shipped [price paid (after discounts, deductions, etc.)]
- A copy of the Freight Bill Invoice from the carrier
- A copy of the Bill of Lading
- Detailed repair invoices (if damaged goods have been repaired)
- An inspection report of the damaged goods (either done by a carrier representative or one performed by you – Waiver of Inspection, Concealed Loss Report, etc.)

The claim should be submitted and all communication with the carrier regarding the claim should be documented. Make copies of all documents sent to the carrier.

NOTE: Products illustrated in this catalog are part of standard systems available from PGA. We have the option to work on any custom product requested by the client. Prices need to be discussed at time of ordering. Our engineers possess unique knowledge on special applications of PGA products and integration of products by third parties into PGA systems. If you need more information regarding utilizing of system components please contact Professional Grade Aluminum for further assistance.

WINDOW

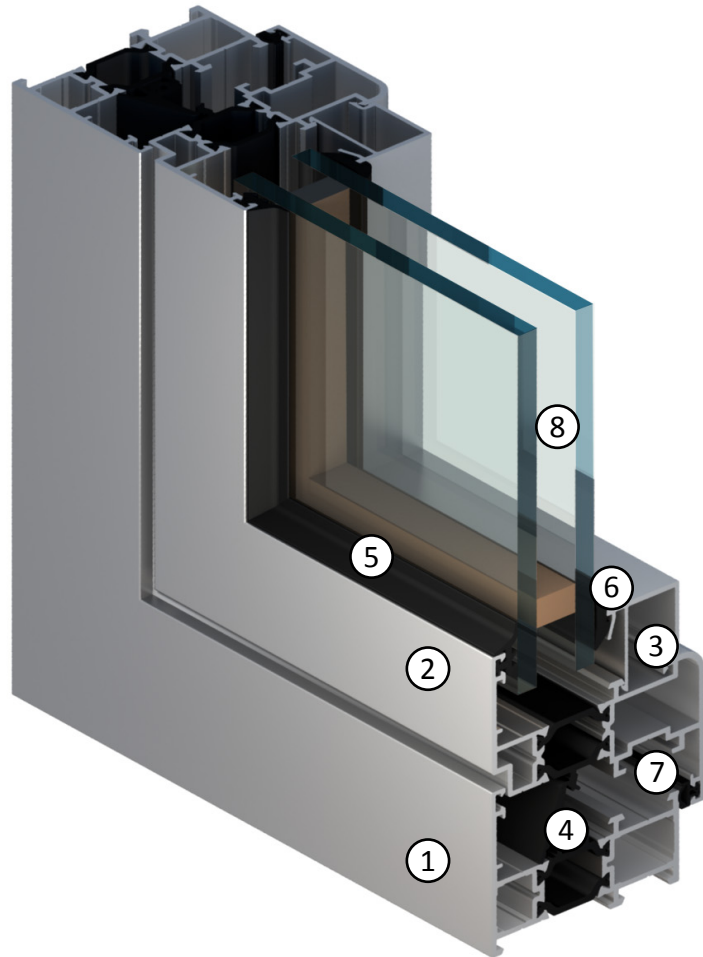

- 1. Frame molding
- 2. Sash molding
- 3. Snap molding
- 4. Gasket
- 5. Gasket
- 6. Gasket
- 7. Gasket
- 8. Insulated glass unit

DOOR

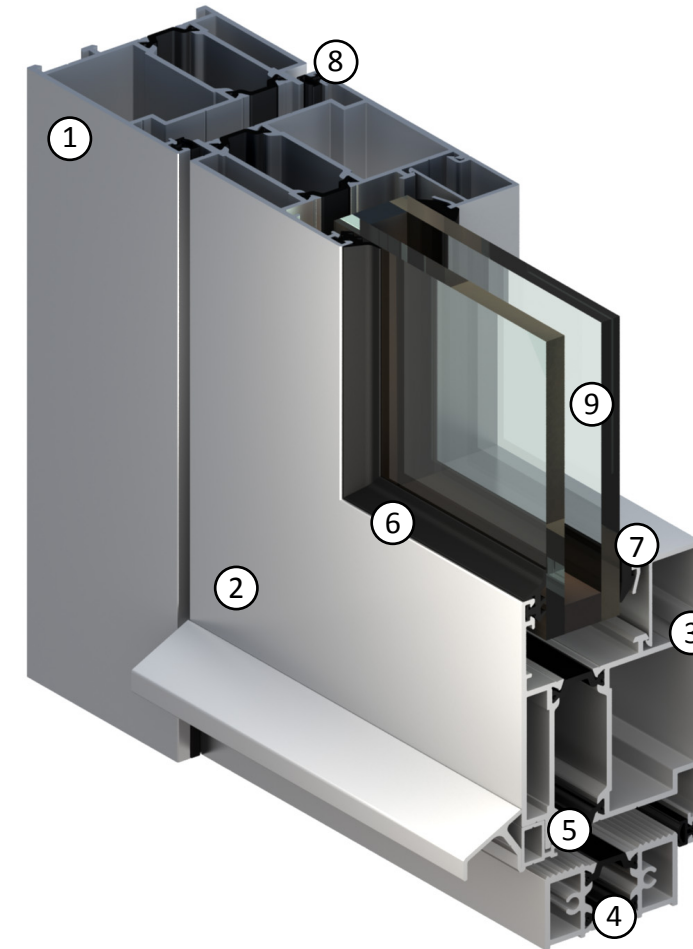

- 1. Door frame molding
- 2. Door panel molding
- 3. Snap molding
- 4. Saddle molding
- 5. Door wipe holder molding
- 6. Gasket
- 7. Gasket
- 8. Gasket
- 9. Insulated glass unit

**SYSTEM EXTRUSIONS
22"-4' NOMINAL LENGTH**

NOT TRUE SIZE
SCALE 1 : 2

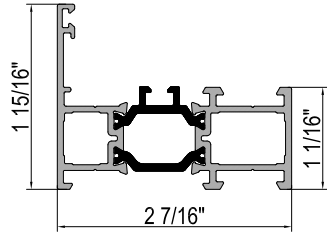
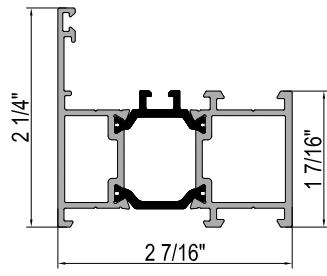
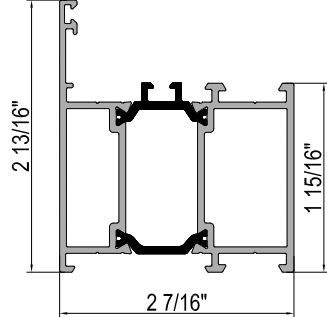
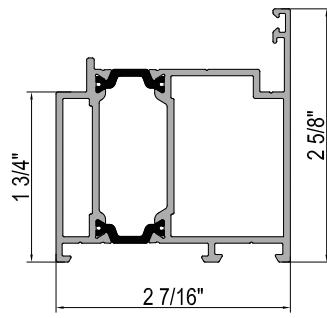
Drawing	Catalog number/ Description
	W62.0101 Window frame molding
	W62.0102 Window frame molding
	W62.0103 Window frame molding
	W62.0104 Door frame molding

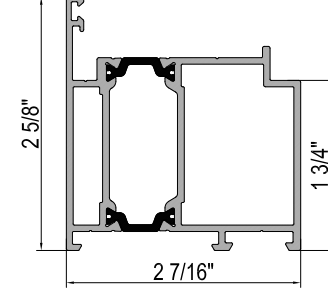
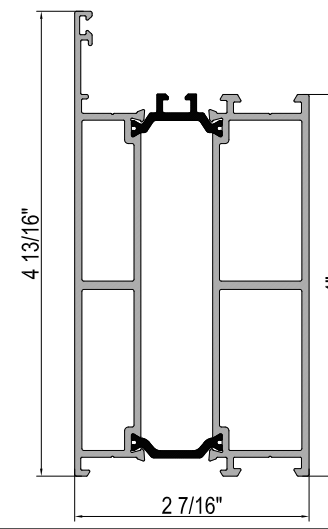
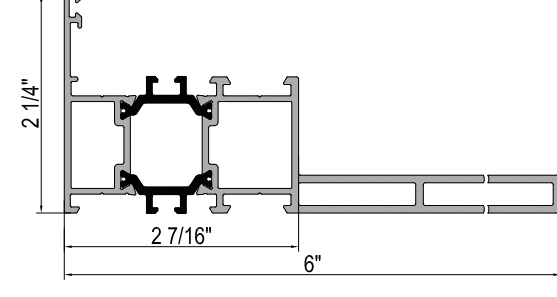

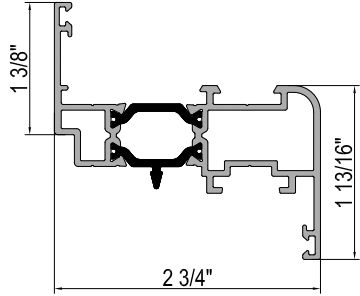
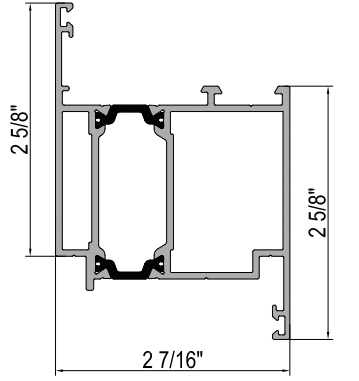
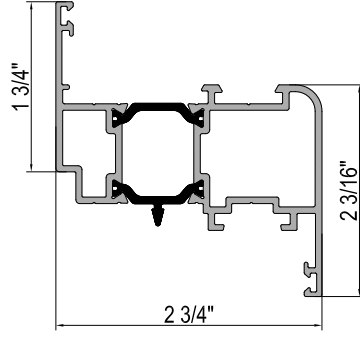
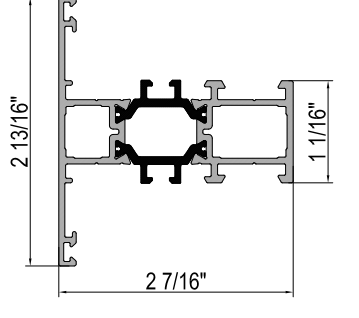
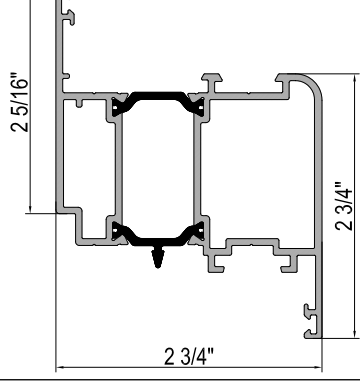
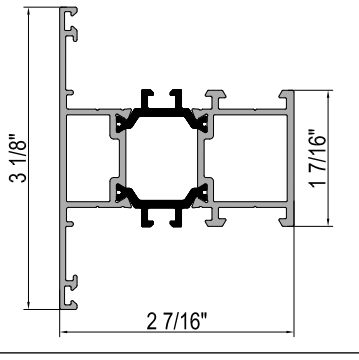
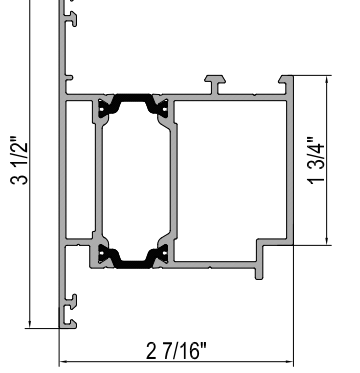
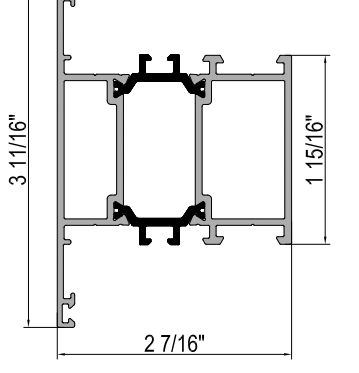
Drawing	Catalog number/ Description
	W62.0105 Door frame molding
	W62.0106 Bottom door rail molding
	W62.0107 Door frame molding

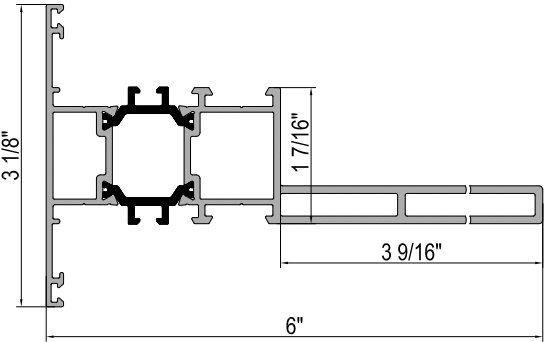
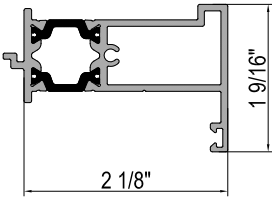
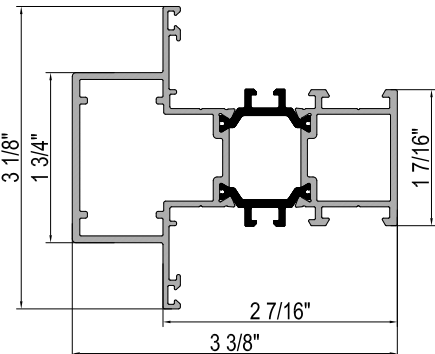
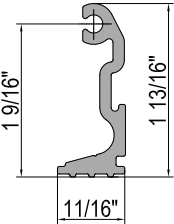
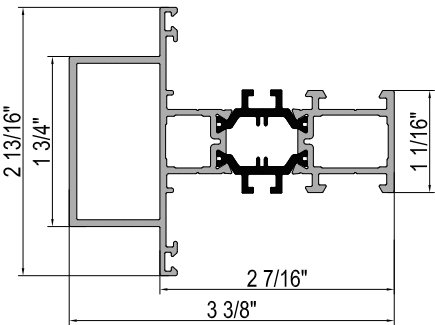
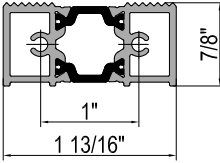
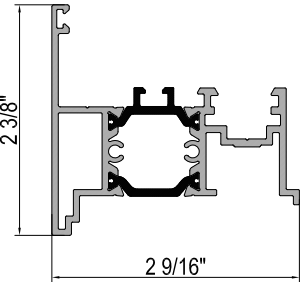
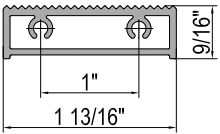
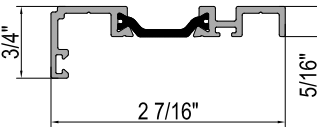
Drawing	Catalog number/ Description	Drawing	Catalog number/ Description
	<p>W62.0201</p> <p>Window sash molding</p>		<p>W62.0205</p> <p>Door panel molding</p>
	<p>W62.0202</p> <p>Window sash molding</p>		<p>W62.0301</p> <p>Divider molding</p>
	<p>W62.0203</p> <p>Window sash molding</p>		<p>W62.0302</p> <p>Divider molding</p>
	<p>W62.0204</p> <p>Door panel molding</p>		<p>W62.0303</p> <p>Divider molding</p>

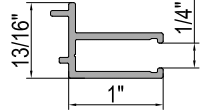
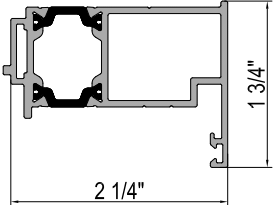
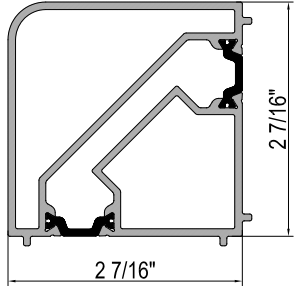
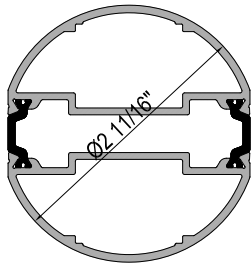
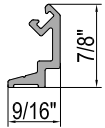
Drawing	Catalog number/ Description	Drawing	Catalog number/ Description
	<p>W62.0304</p> <p>Divider molding</p>		<p>W62.0502</p> <p>Inactive door adaptor molding</p>
	<p>W62.0305</p> <p>Divider molding</p>		<p>W62.0701</p> <p>Divider block molding</p>
	<p>W62.0306</p> <p>Divider molding</p>		<p>W62.0801</p> <p>Saddle molding</p>
	<p>W62.0501</p> <p>Window adaptor molding</p>		<p>W62.0802</p> <p>Saddle molding</p>
			<p>W62.0803</p> <p>Door bottom molding</p>

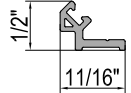
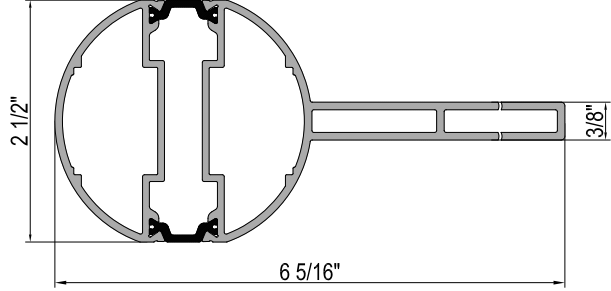
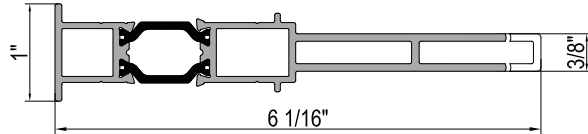
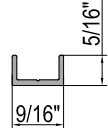
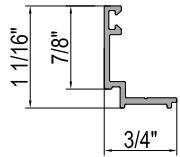
Drawing	Catalog number/ Description
	W62.0804 Temperature compensation molding
	W62.0805 Door adaptor molding
	W62.0806 Corner molding
	W62.0807 Variable angle connector molding
	W62.0808 Return adaptor molding

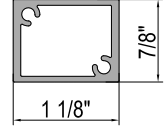
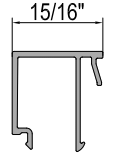
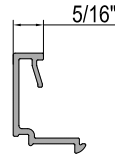
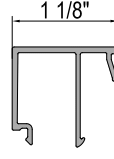
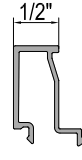
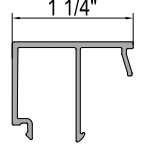
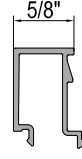
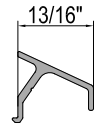
Drawing	Catalog number/ Description
	W62.0809 Return adaptor molding
	W62.0811 Variable angle connector molding
	W62.0812 180 degree connector molding
	C48.0614 Line up molding
	C48.0615 Door adaptor molding

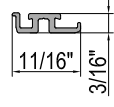
Drawing	Catalog number/ Description	Drawing	Catalog number/ Description
	110.0702 Reinforcement molding		C48.0606 Snap molding
	C48.0602 Snap molding		C48.0607 Snap molding
	C48.0603 Snap molding		C48.0608 Snap molding
	C48.0604 Snap molding		C48.0611 Water deflector molding
	C48.0605 Snap molding		W62.0601 Locking rod for Ribanta 5 window hardware 13' long

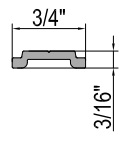
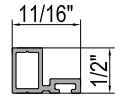
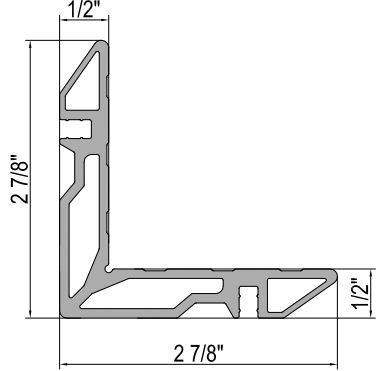
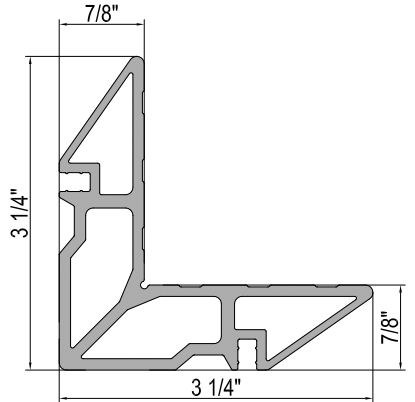

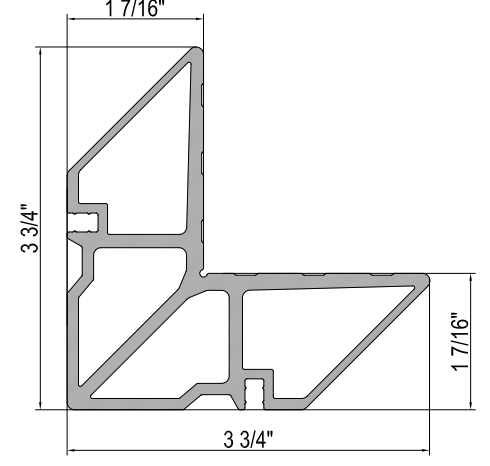
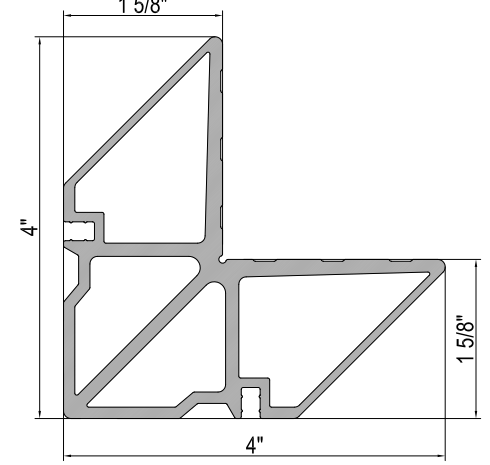
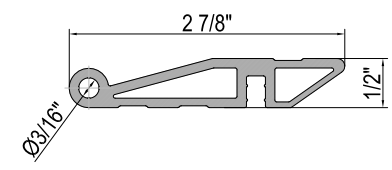
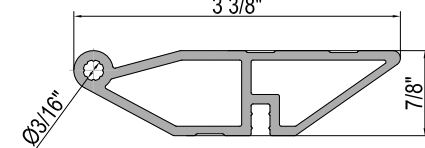
Drawing	Catalog number/ Description
	C48.0612 Standard h/w locking rod
	C48.0618 Door wipe holder molding
	C48.0702 Corner key molding
	C48.0703 Corner key molding

Drawing	Catalog number/ Description
	C48.0704 Corner key molding
	C48.0705 Corner key molding
	C48.0707 Corner key molding
	C48.0708 Corner key molding

RUBBER GASKETS

NOT TRUE SIZE
SCALE 1 : 2

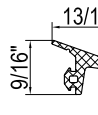

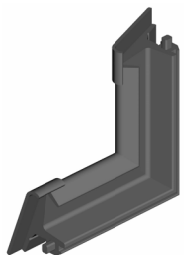
Drawing	Catalog number/ Description
	FRK101
	Gasket 1148'
	FRK98
	Gasket 492'
	FRK28
	Gasket 1886'
	FRK07
	Gasket 1312'
	FRK29-01
	Gasket 1312'
	FRK38
	Gasket 1312'
	FRK36
	Gasket 820'

Drawing	Catalog number/ Description
	FRK67
	Gasket 656'
	FRK51
	Gasket 394'
	PB048.0750-FP
	Felt sealant 3280'
	FRK52
	Rubber angle 50ps

PLASTIC COMPONENTS

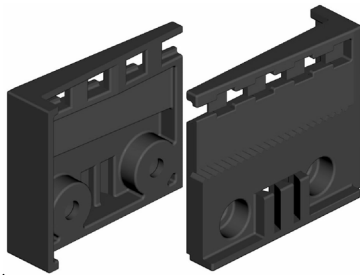
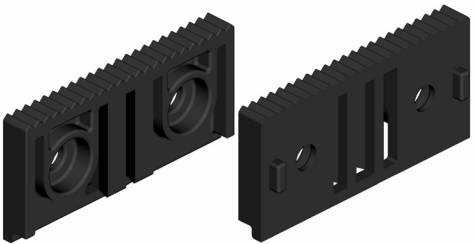
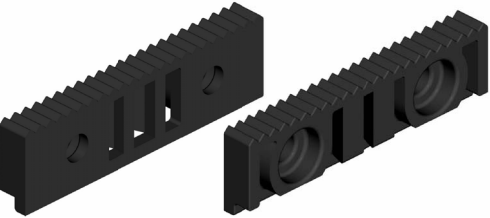
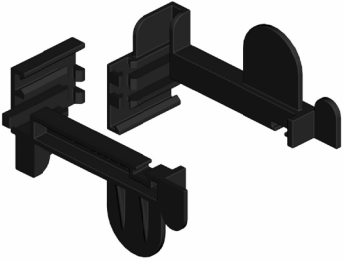
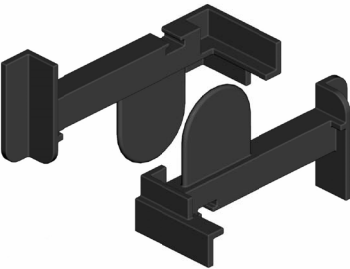
NOT TRUE SIZE

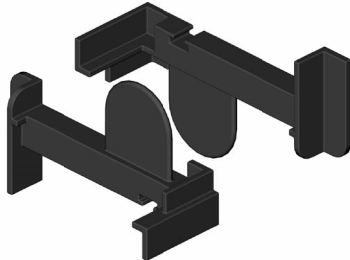
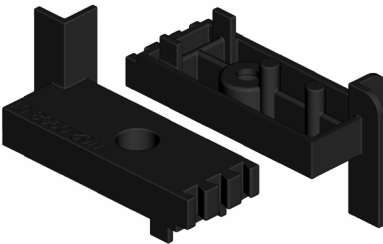
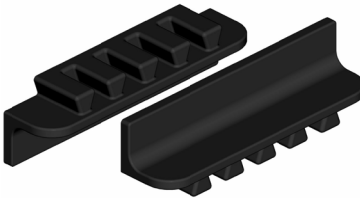
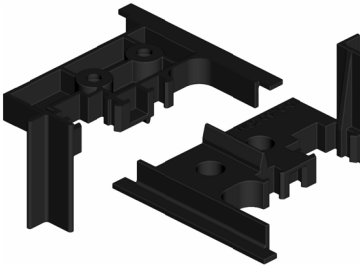
Drawing	Catalog number/ Description
	W62.0902
	Wipe holder
	W62.0903
	Saddle end cap
	W62.0904
	Saddle end cap
	W62.0905
	End caps for W62.0803 molding
	W62.0906
	End caps for W62.0803 molding

Drawing	Catalog number/ Description
	W62.0907
	End caps for W62.0803 molding
	W62.0908
	End caps for W62.0502 molding
	W62.0909
	End caps for W62.0502 molding
	W62.0910
	End caps for W62.0502 molding
	C48.0919
	Vent hole cap

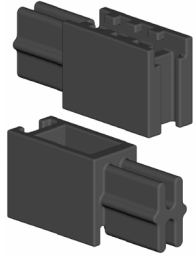
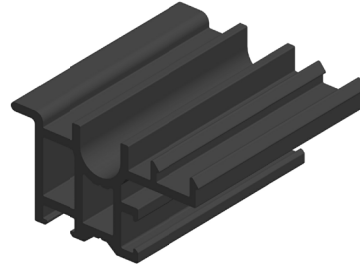
Drawing	Catalog number/ Description
	C48.0906
	Door end cap
	C48.0907
	Door end cap
	C48.0909
	End caps for C48.0618
	W72.0920
	Universal plastic adaptor

SHIMS

NOT TRUE SIZE

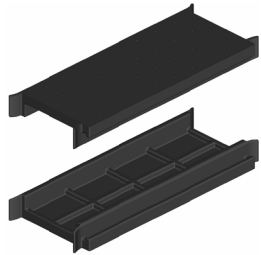
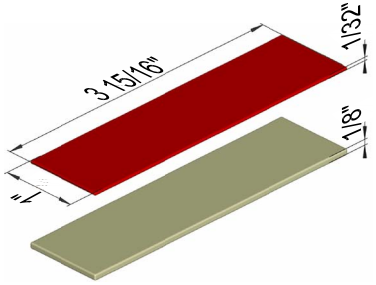
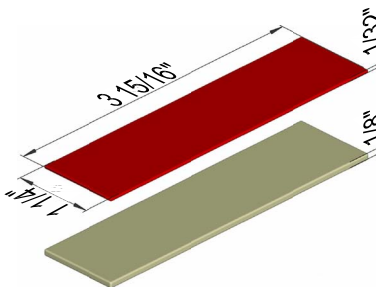
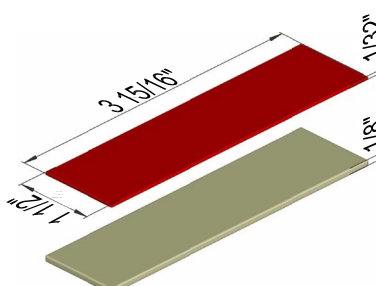
Drawing	Catalog number/ Description
	W62.0901
	Glass support
	100x26x1
	Glass shim
	100x26x3
	Glass shim
	100x32x1
	100x32x3
	Glass shim
	100x38x1
	100x38x3
	Glass shim

BLOCKS AND CORNER KEYS

NOT TRUE SIZE

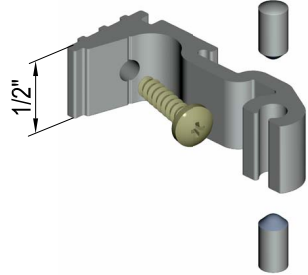
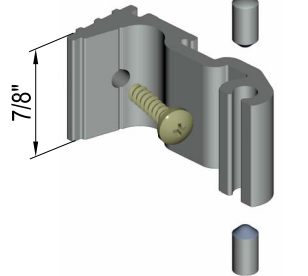
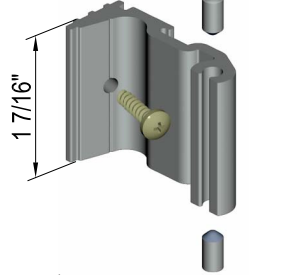
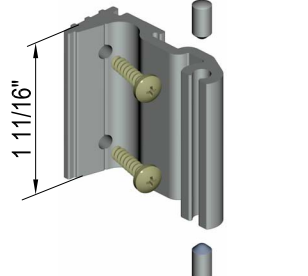
Drawing	Catalog number/ Description
	W62.0951
	Divider block
	W62.0951-01
	Divider block
	W62.0951-02
	Divider block
	W62.0951-03
	Divider block

Drawing	Catalog number/ Description
	W62.0952
	Corner key
	W62.0952-03
	Corner key
	W62.0952-01
	Corner key
	W62.0952-02
	Corner key
	W62.0953
	Corner key

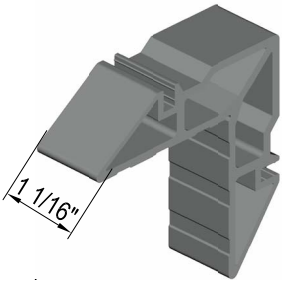
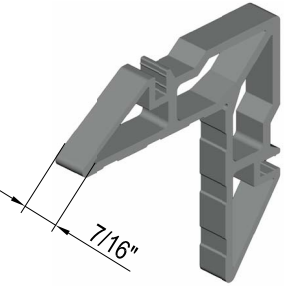
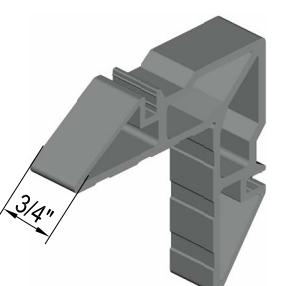
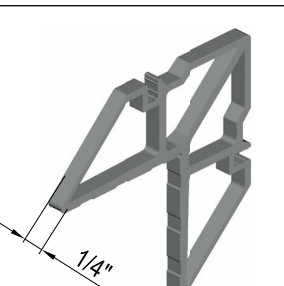
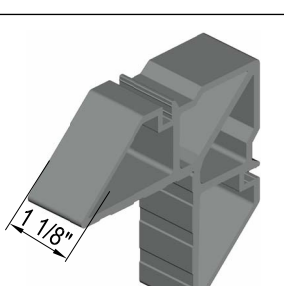
Drawing	Catalog number/ Description
	W62.0953-03 Corner key
	W62.0953-01 Corner key
	W62.0953-02 Corner key
	W62.0954 Corner key
	W62.0954-01 Corner key

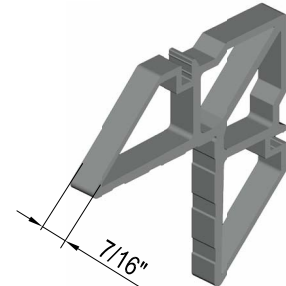
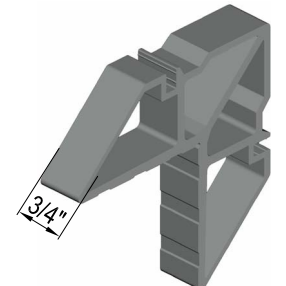
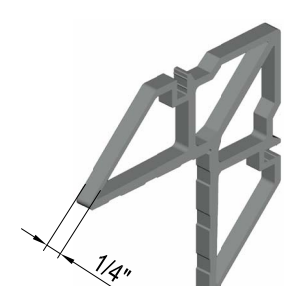
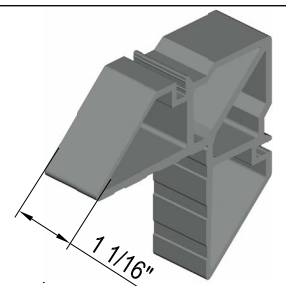
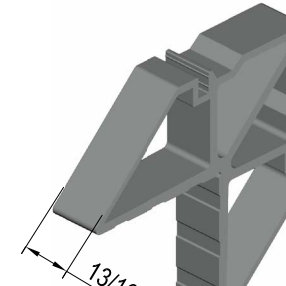
Drawing	Catalog number/ Description
	W62.0954-02 Corner key
	W62.0954-03 Corner key
	W62.0954-04 Corner key
	W62.0954-05 Corner key
	W62.0955-02 Corner key

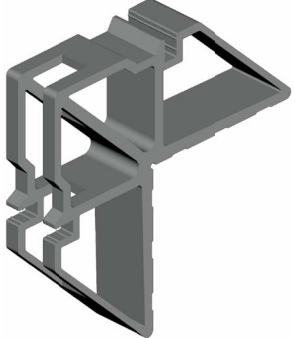
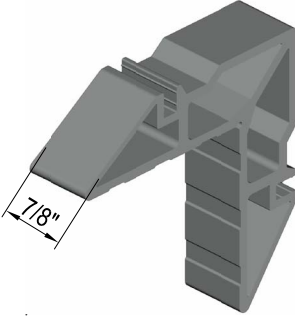
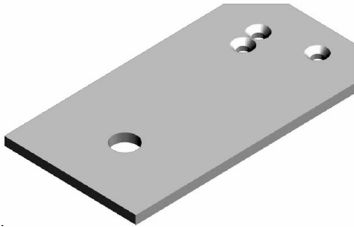
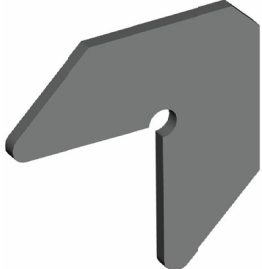
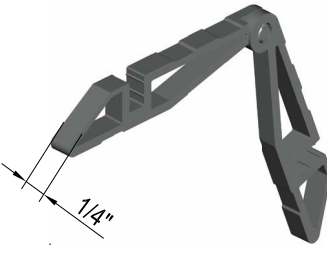
Drawing	Catalog number/ Description
	W62.0956 Corner key
	W62.0953-04 Corner key
	110.0943 Plate
	W62.0957 Aluminum angle
	W62.0960 Corner key

Drawing	Catalog number/ Description
	W62.0960-03 Corner key
	W62.0960-01 Corner key
	W62.0960-02 Corner key
	W62.0955 Corner key
	W62.0955-01 Corner key

Drawing	Catalog number/ Description
	<p>W62.0962</p> <p>Corner key</p>
	<p>W62.0962-03</p> <p>Corner key</p>
	<p>W62.0962-01</p> <p>Corner key</p>
	<p>W62.0962-02</p> <p>Corner key</p>

GLASS SHIMS INSTALLATION GUIDE

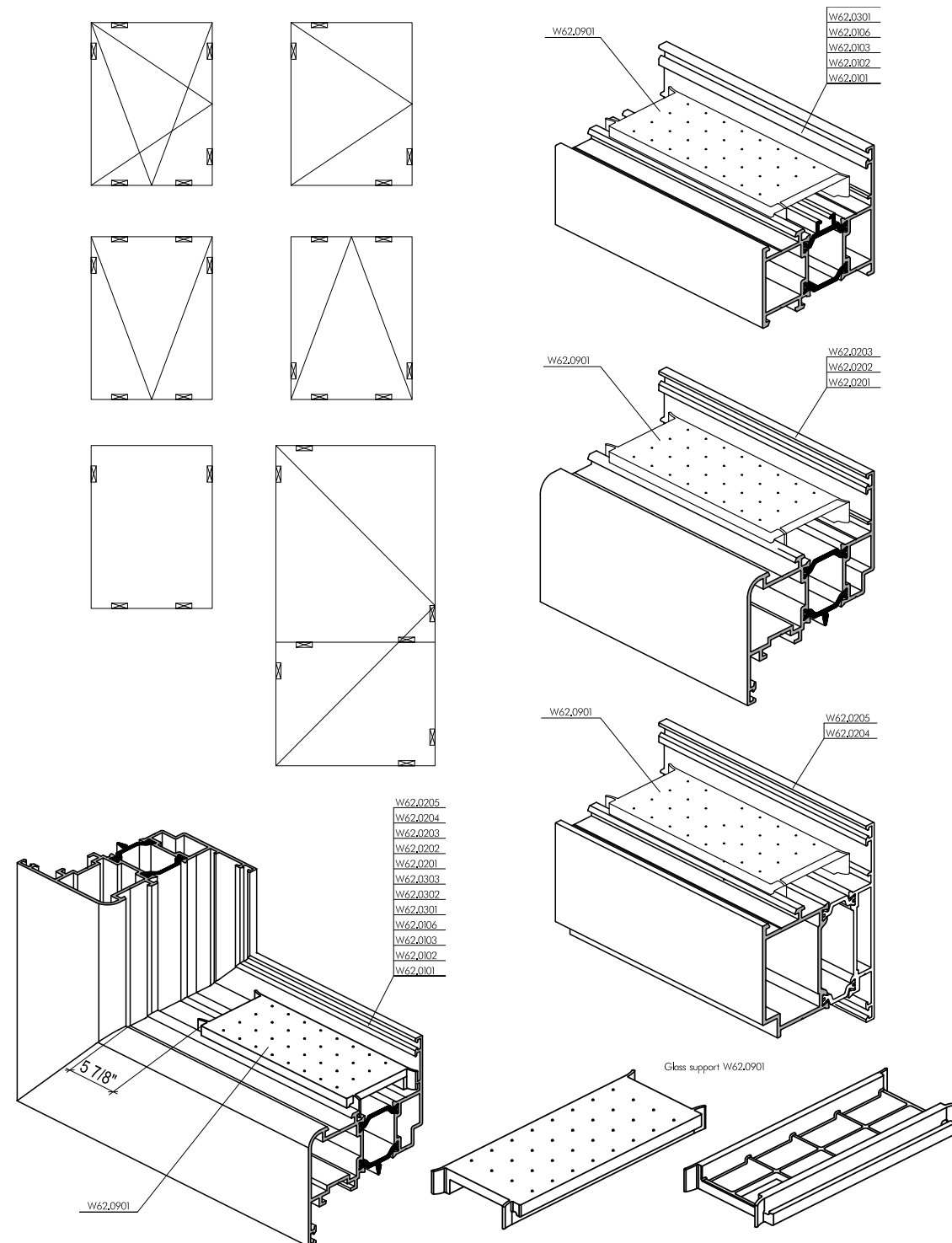

GASKETS INSTALLATION INSTRUCTIONS

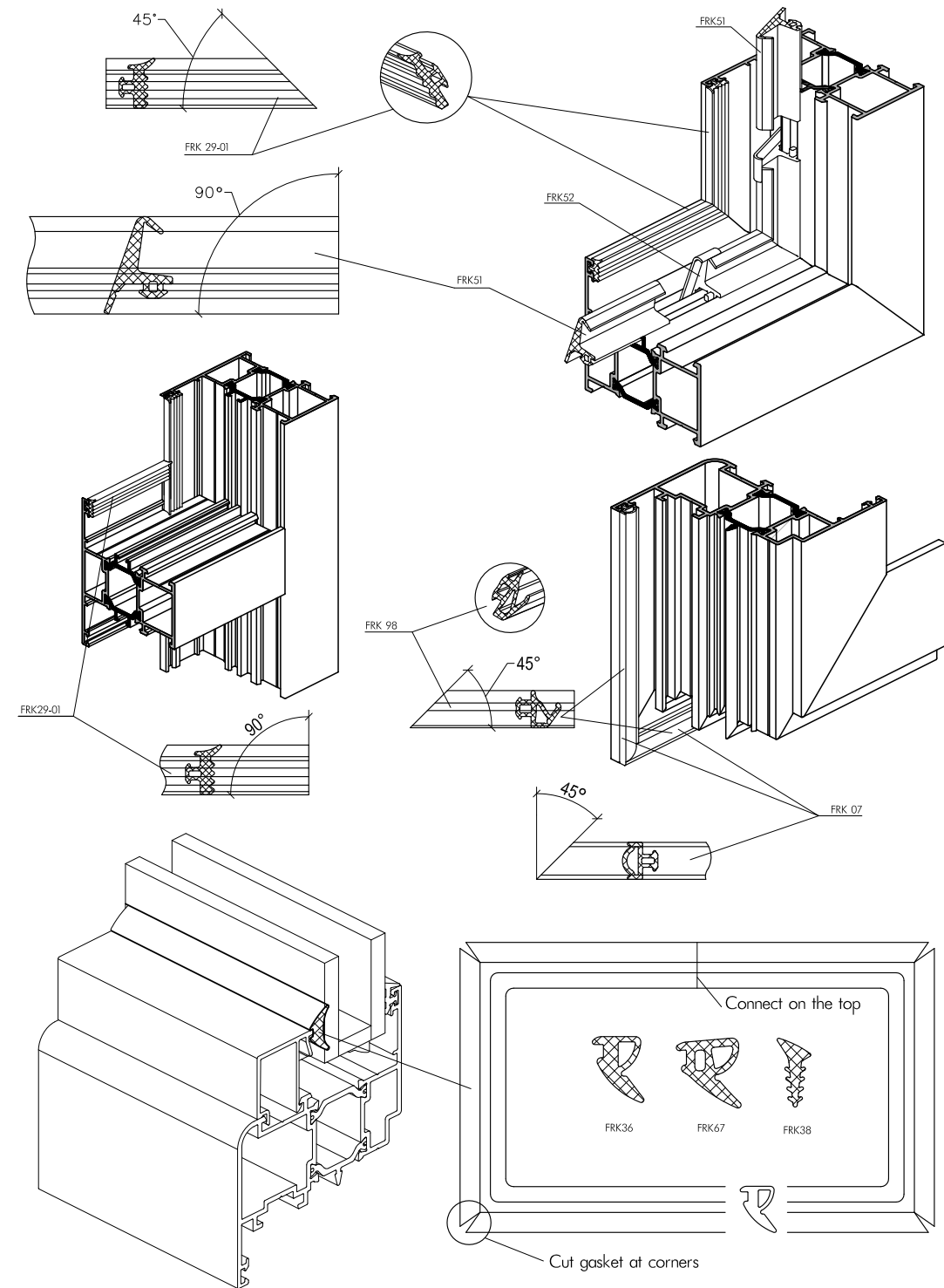

⚠ Apply cyanoacrylate glue. Follow glue manufacturer's instructions.

GLAZING OPTIONS

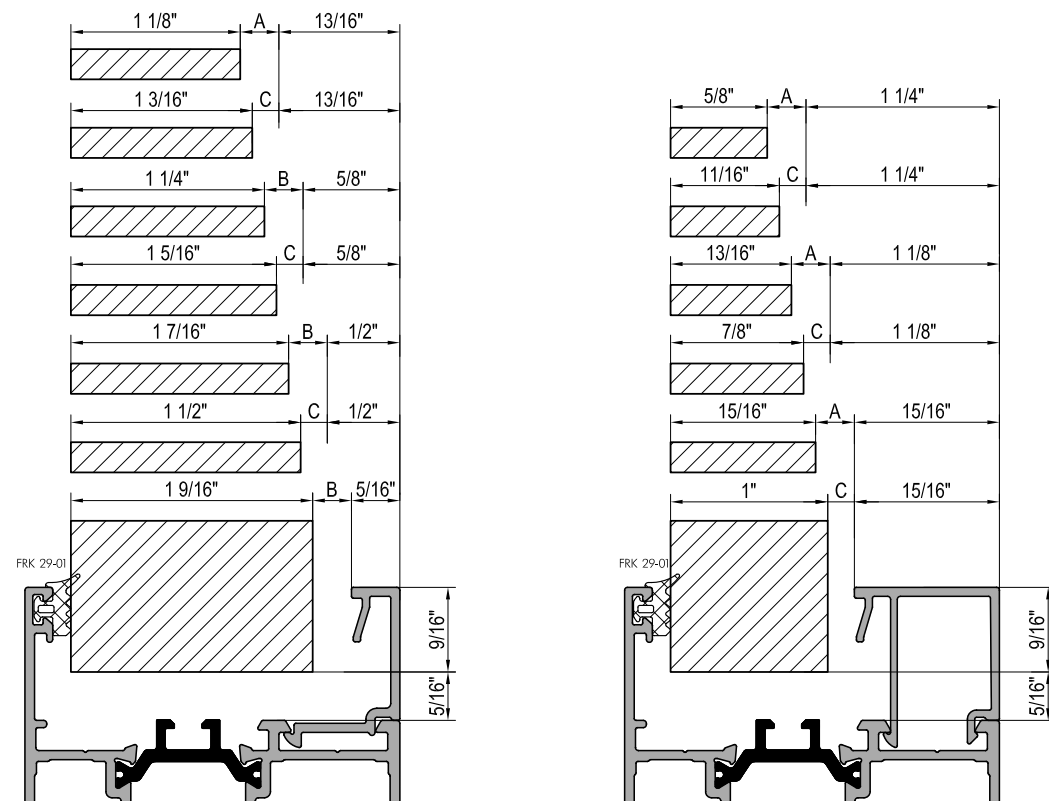
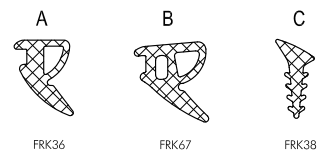
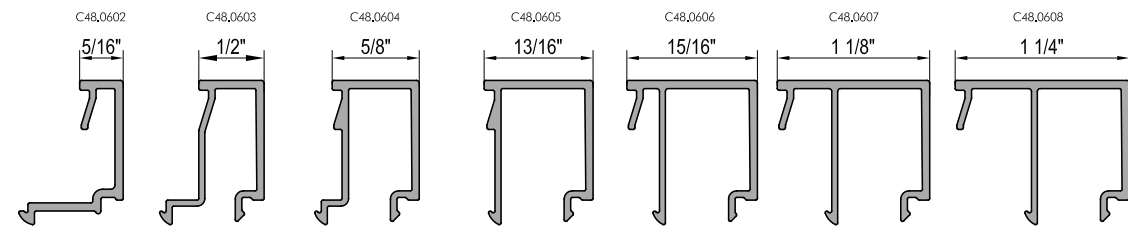

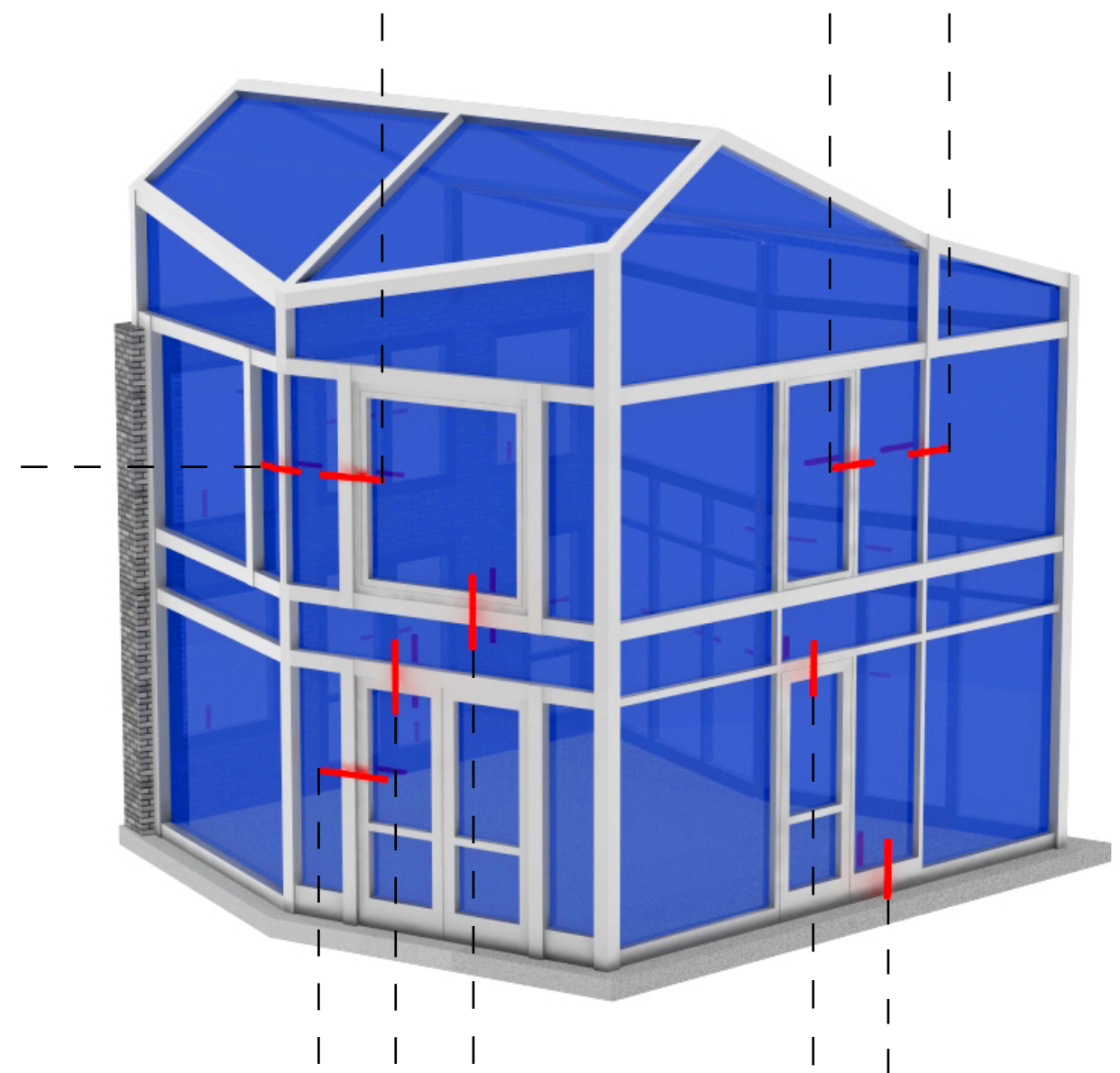
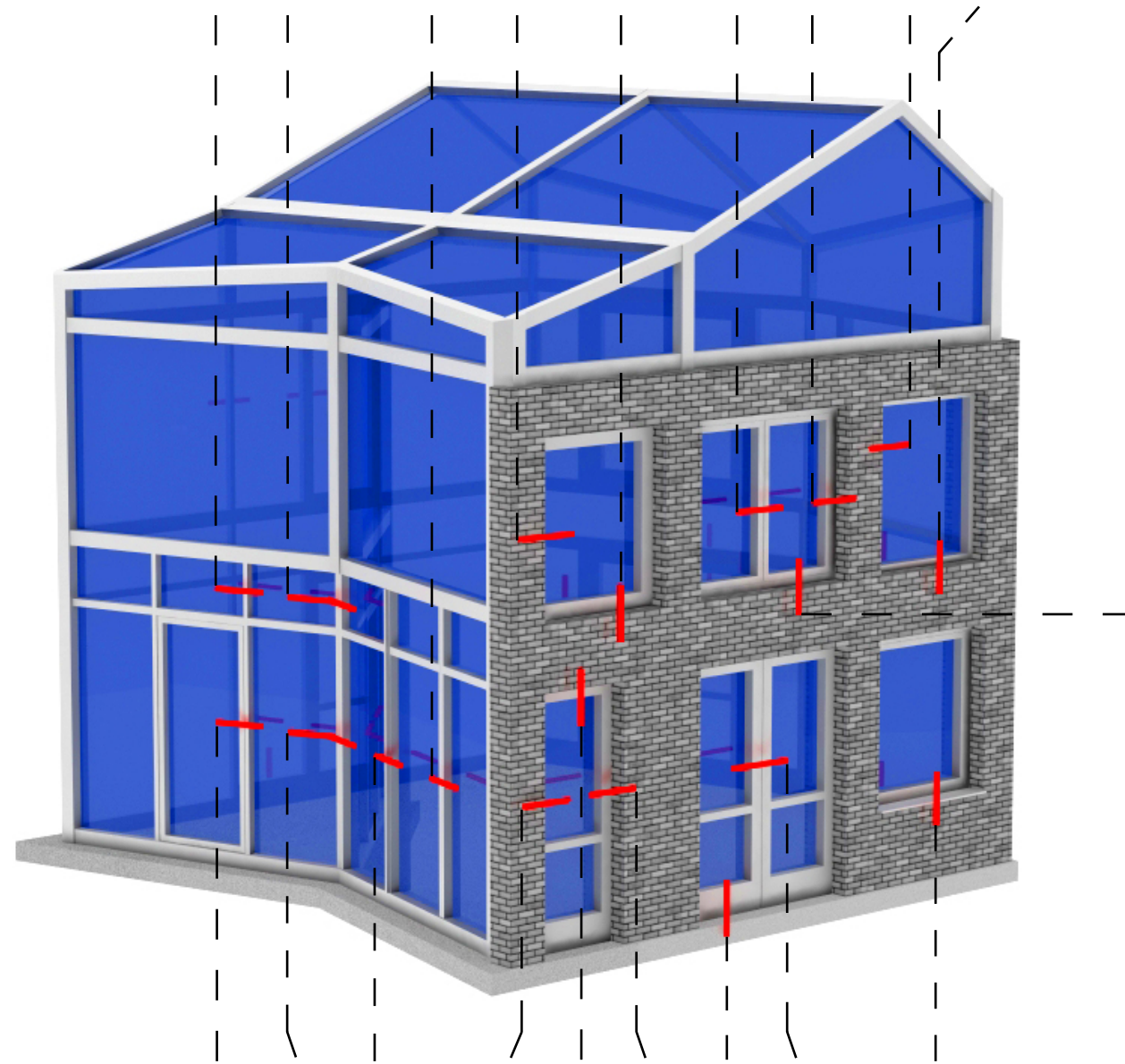

TYPICAL SECTIONS (WINDOWS)

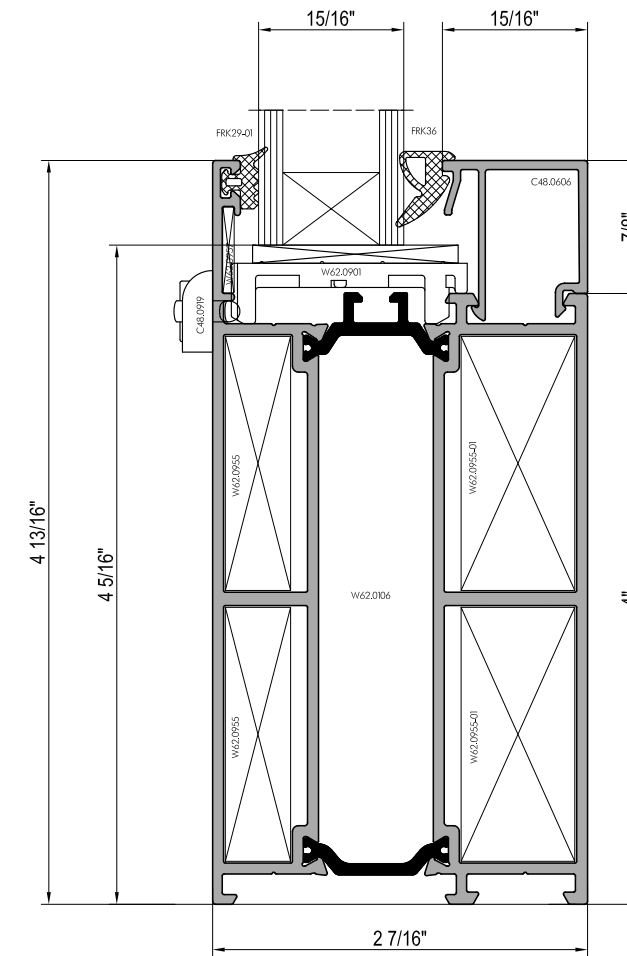
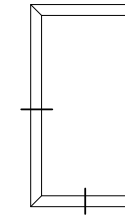
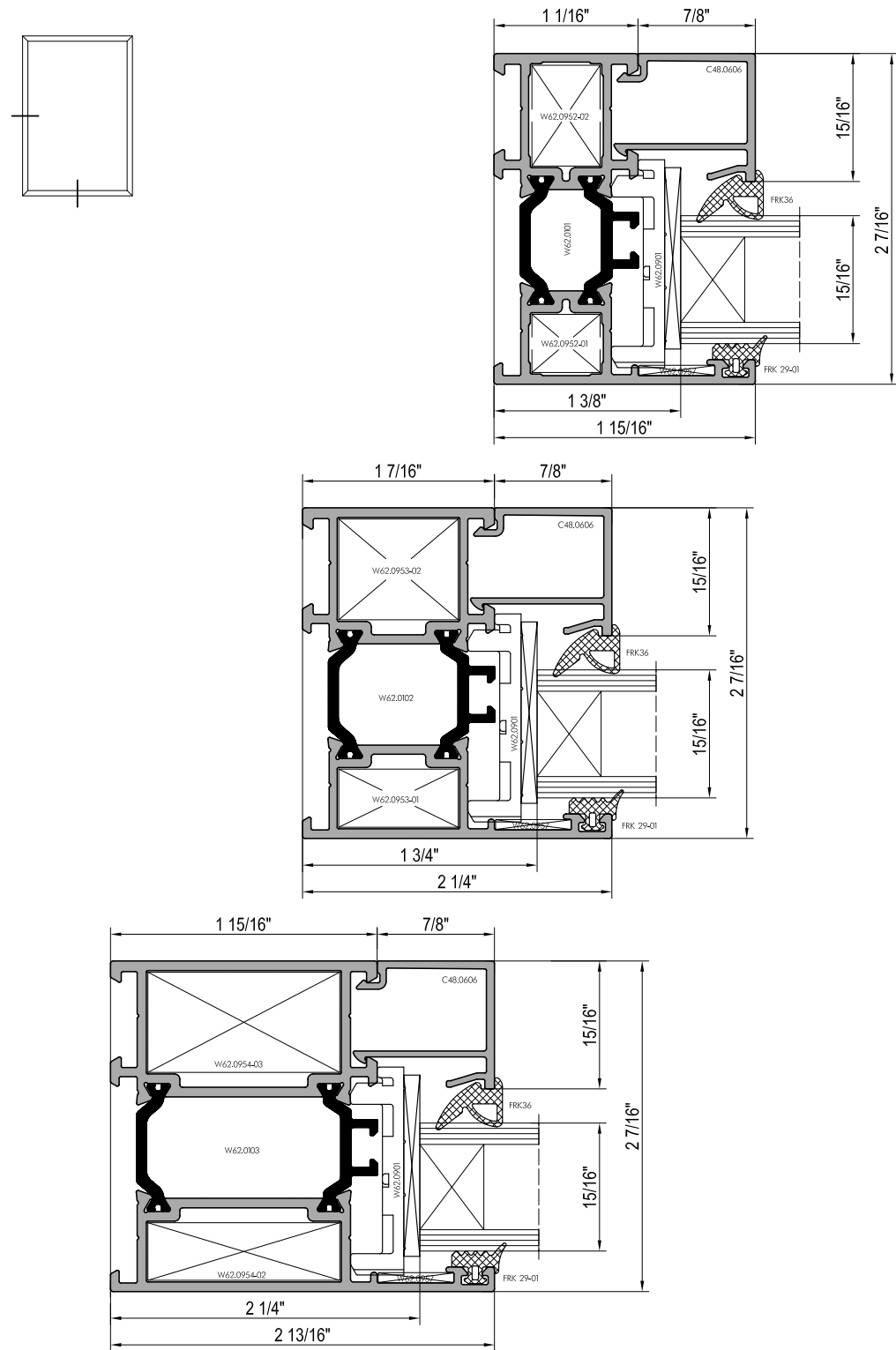

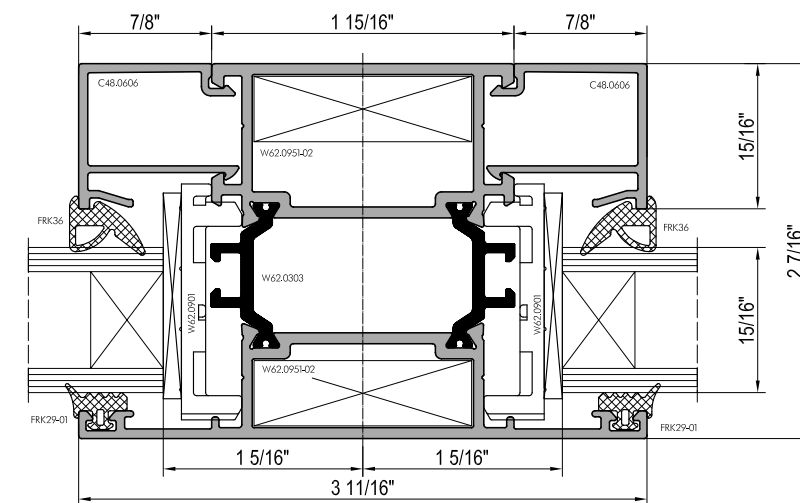
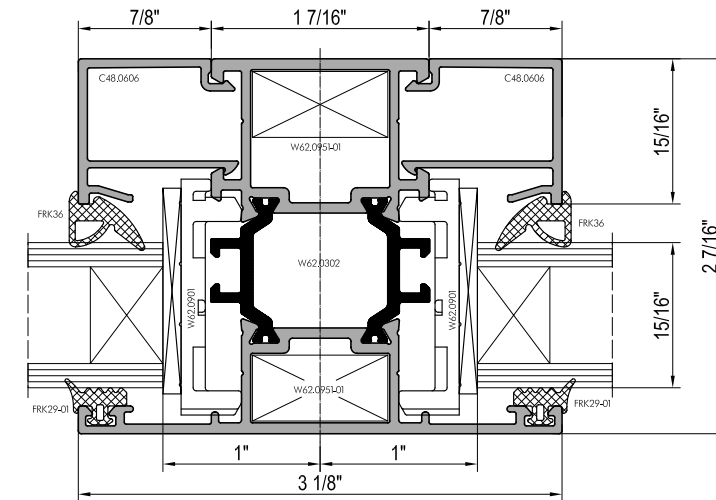
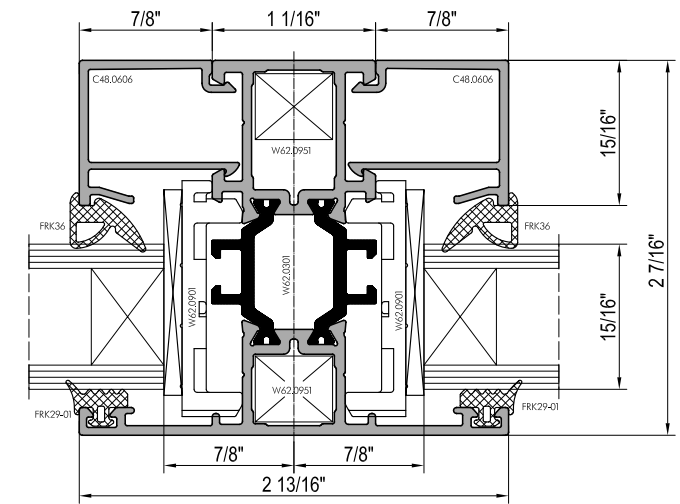
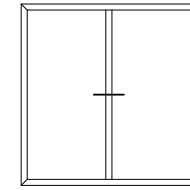
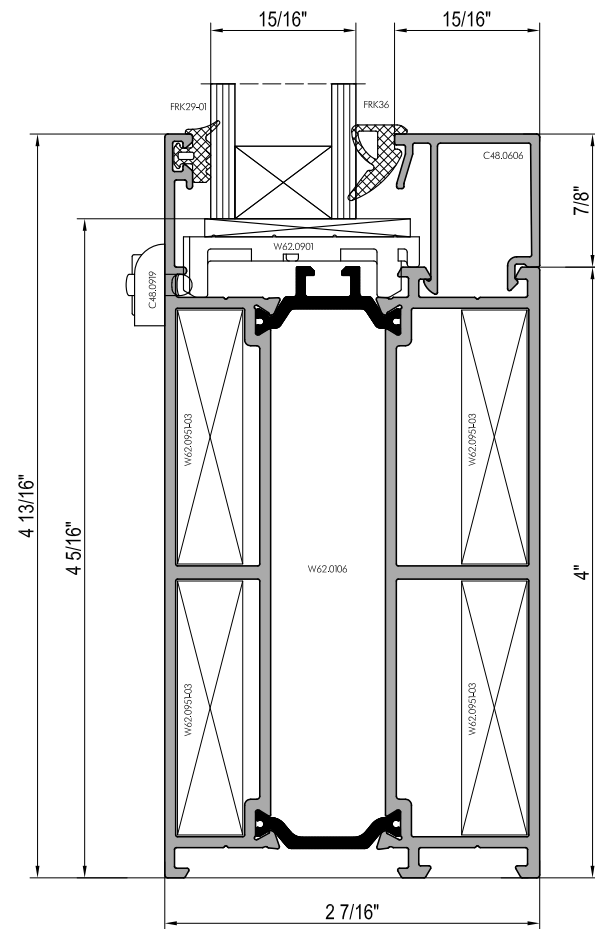

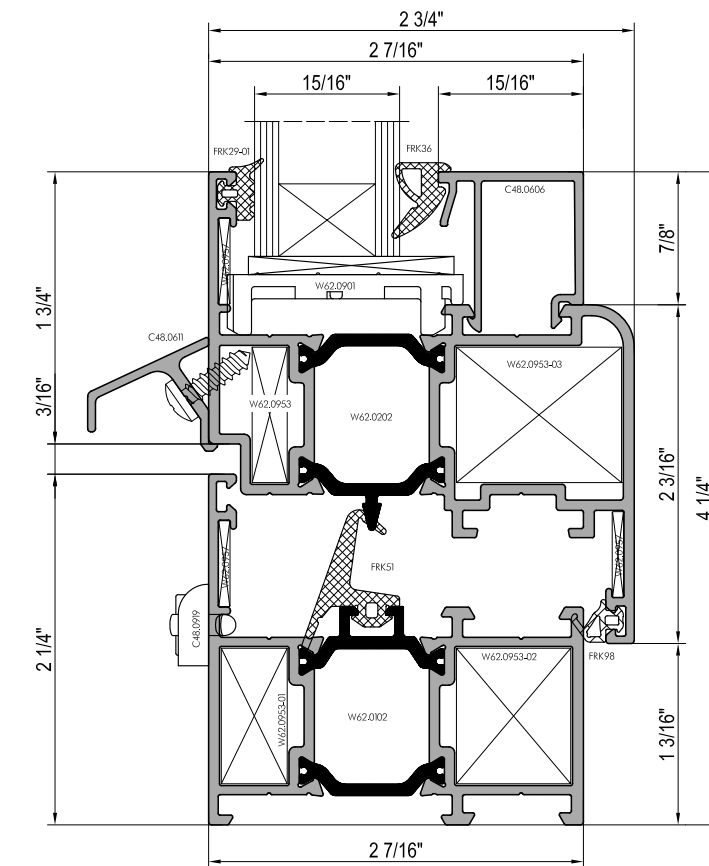
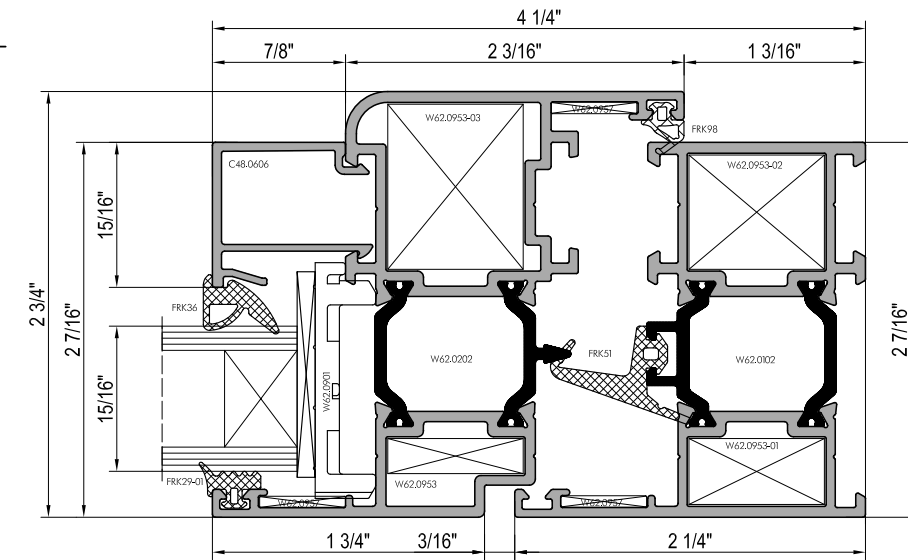
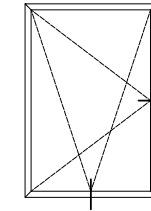
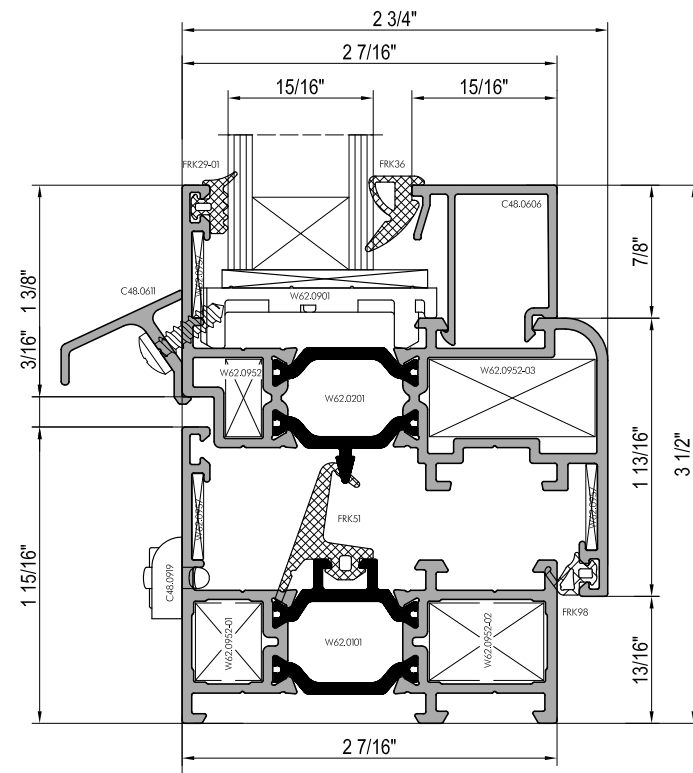
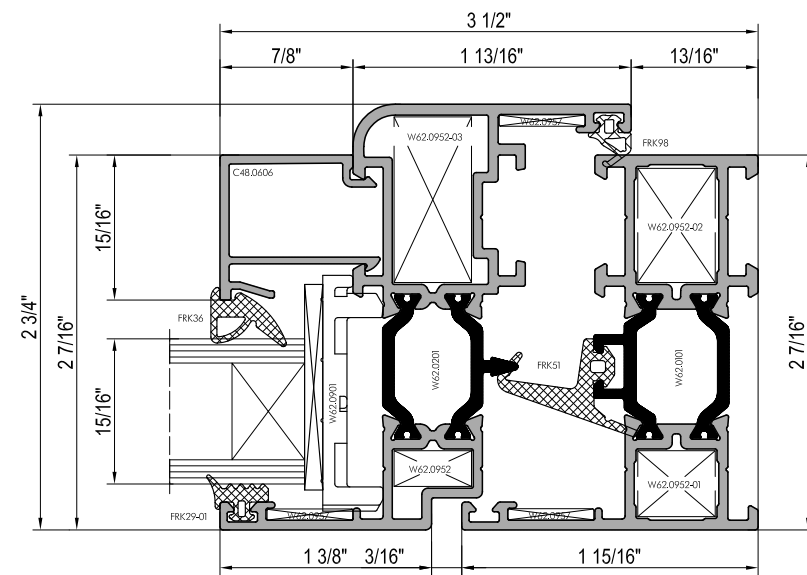
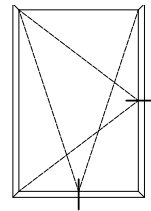

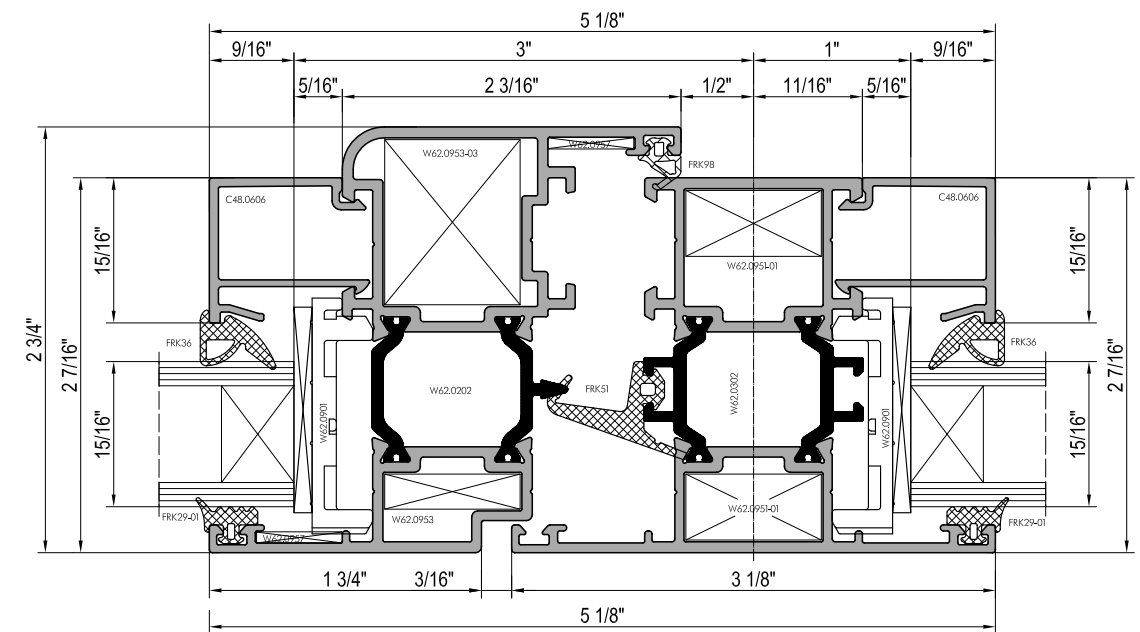
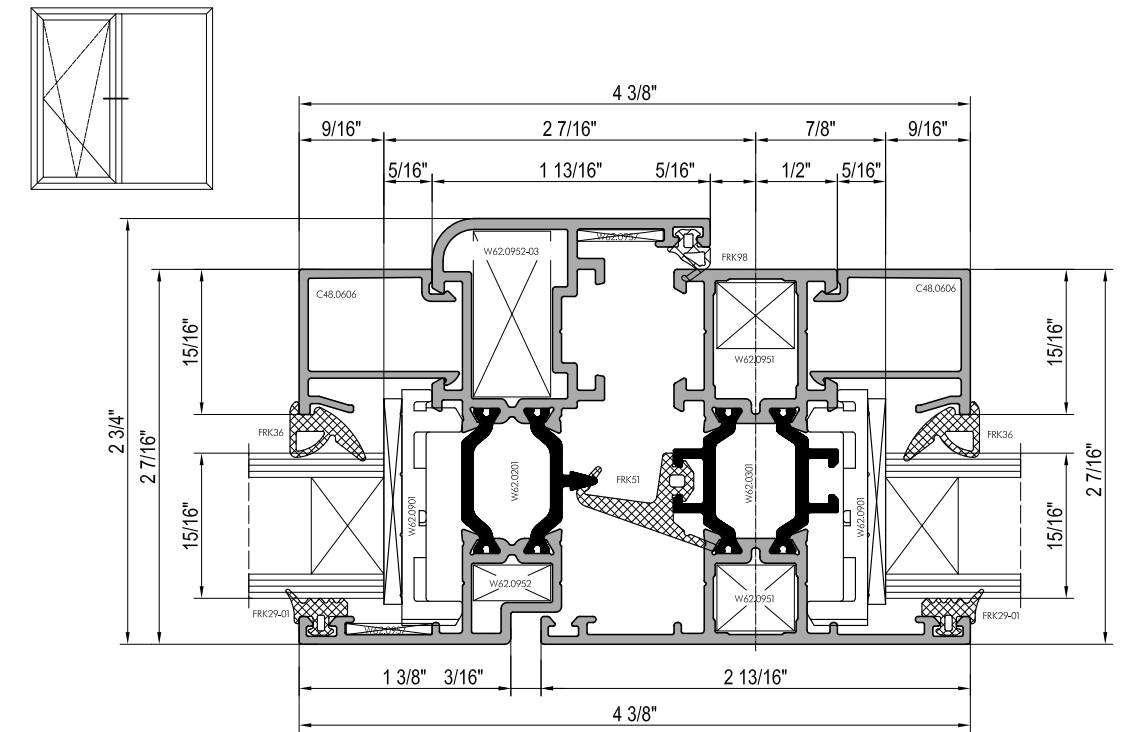
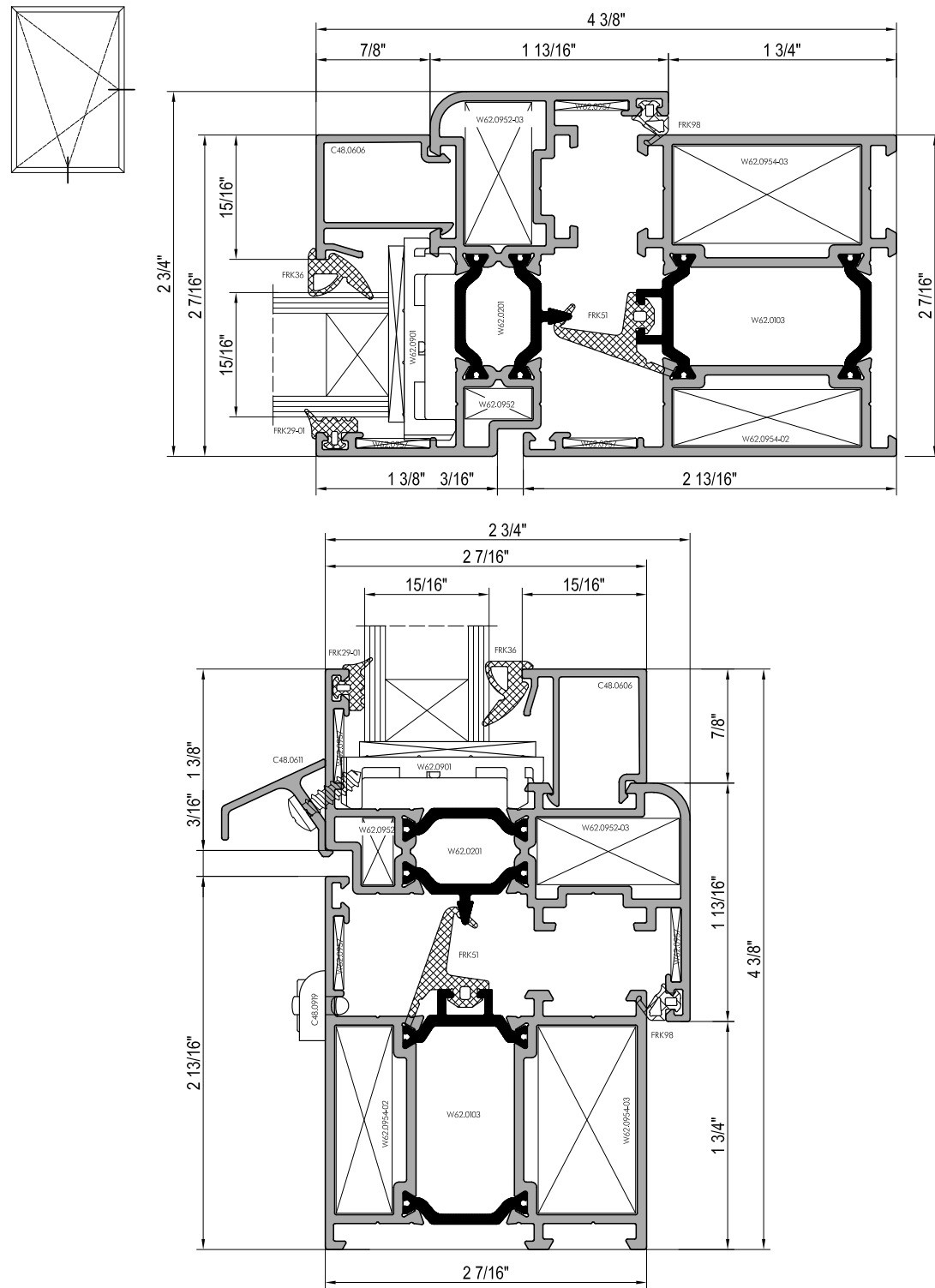

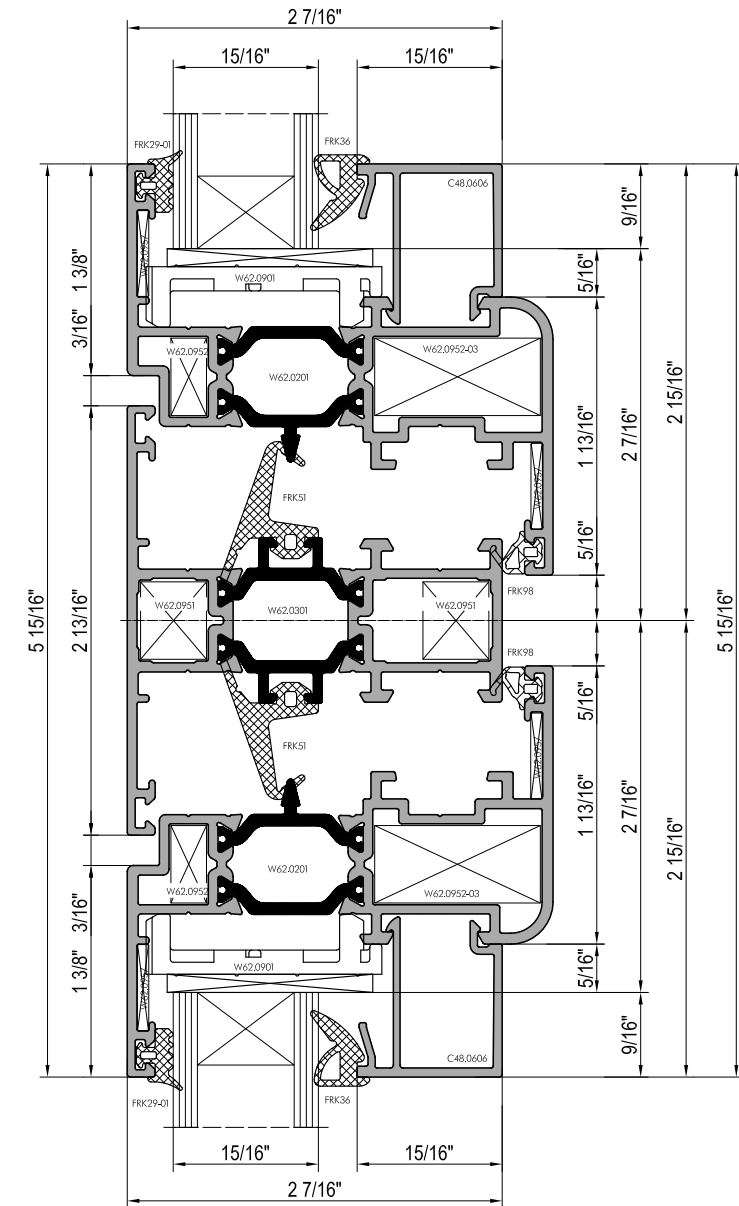
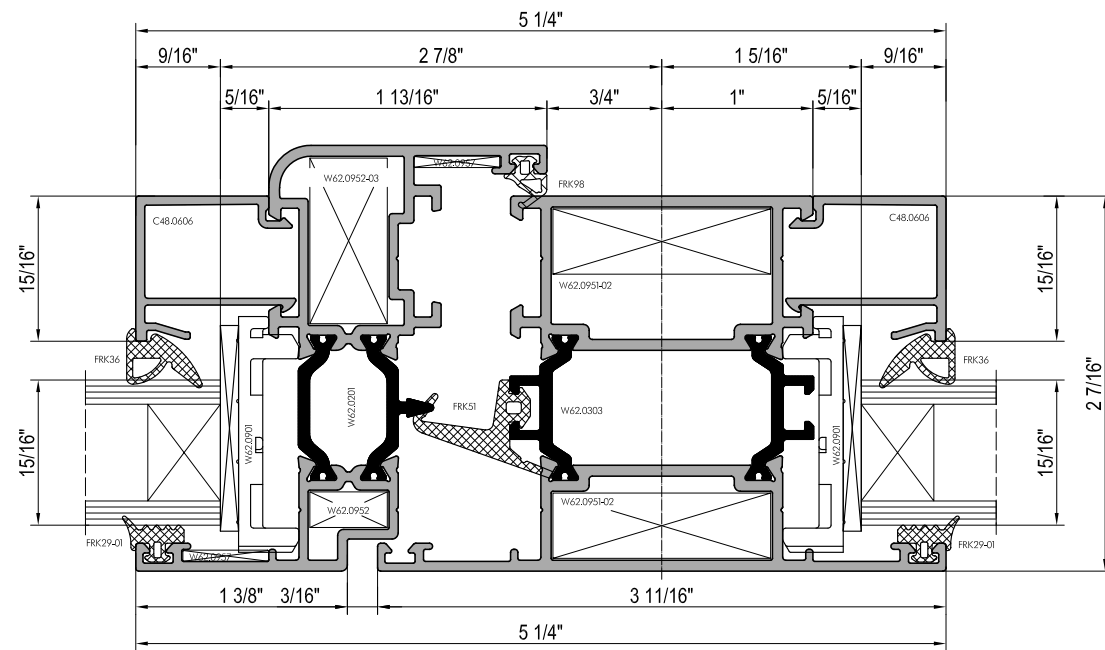
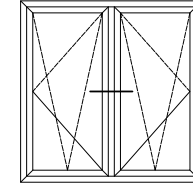
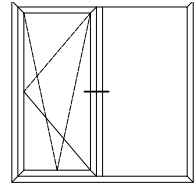

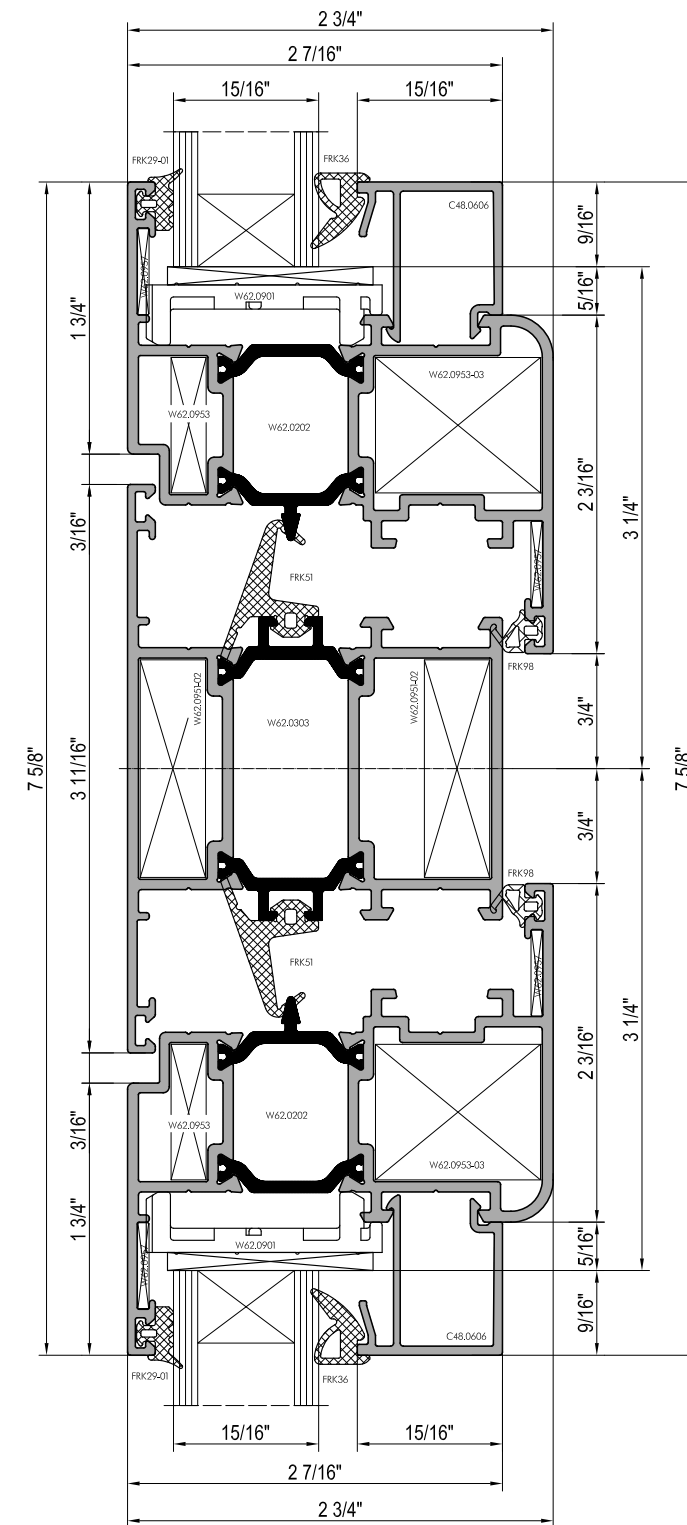
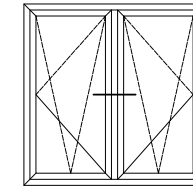
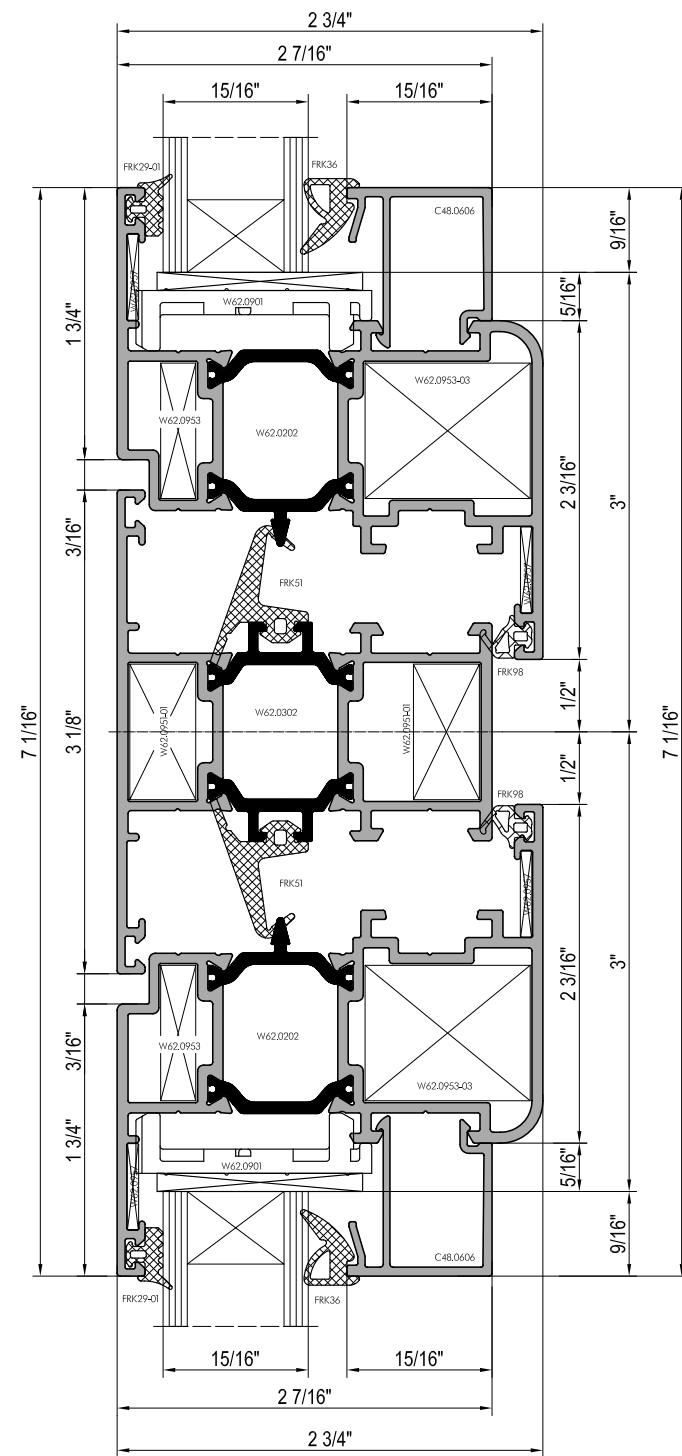
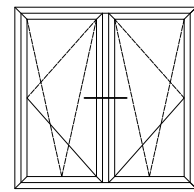

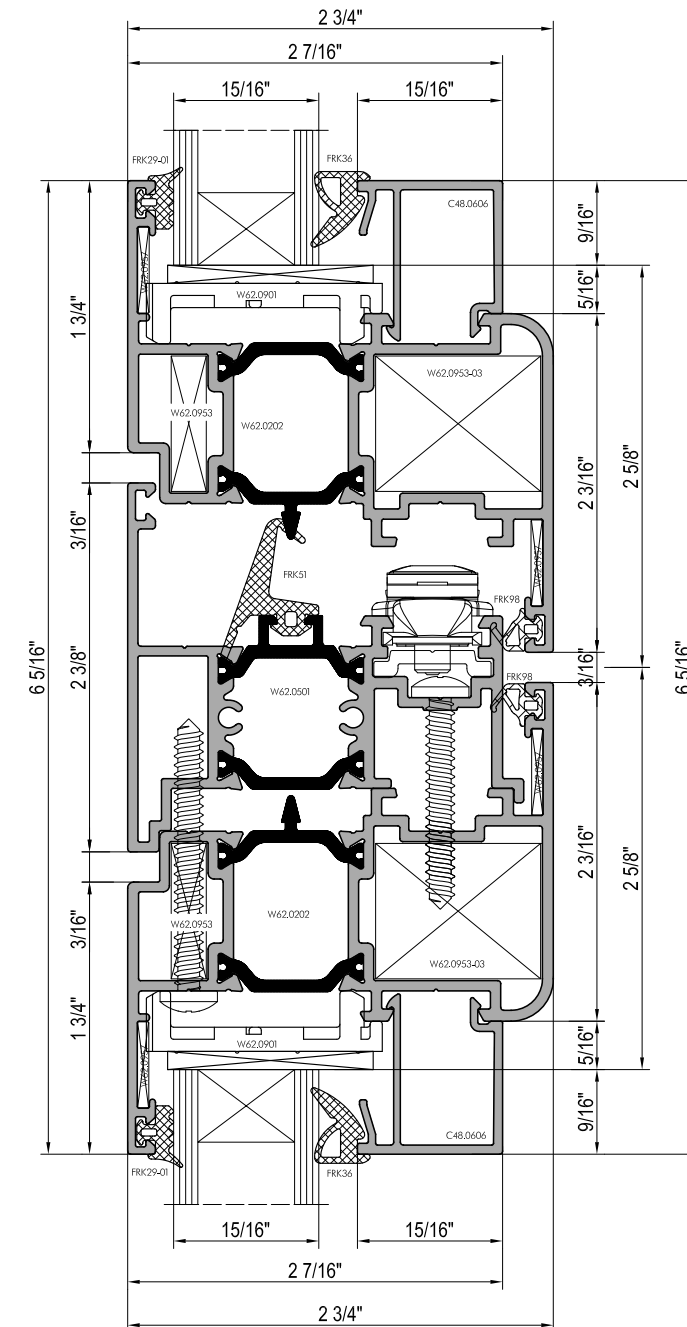
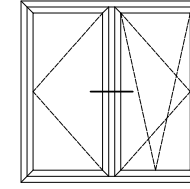
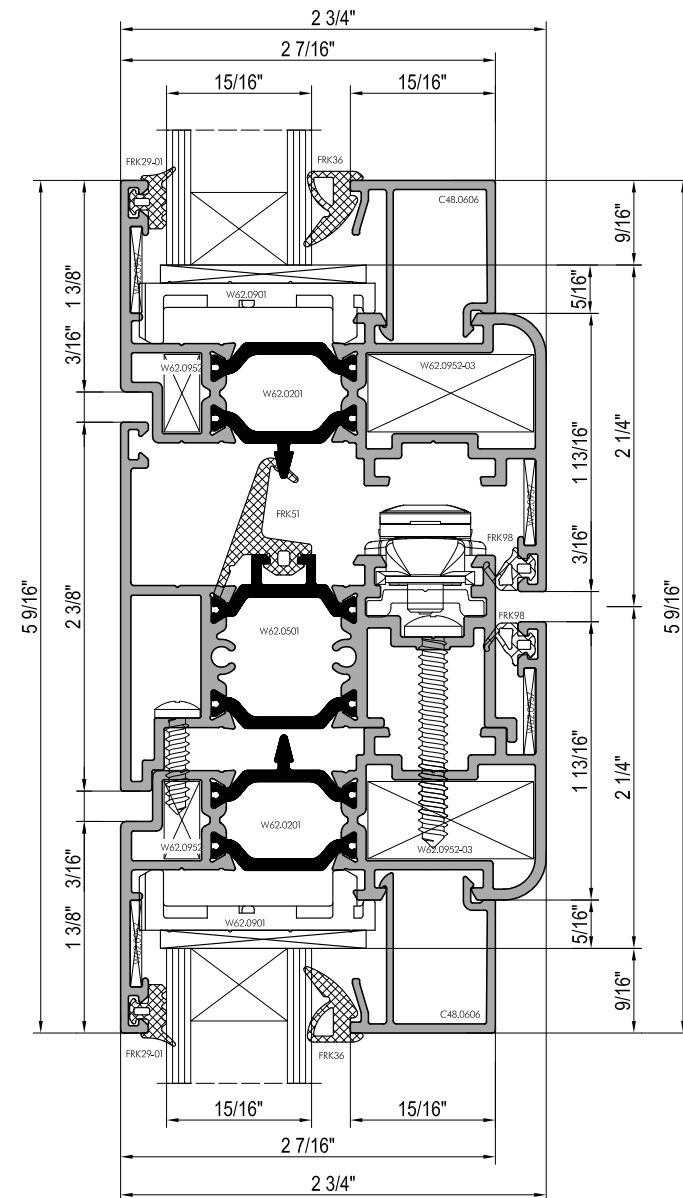
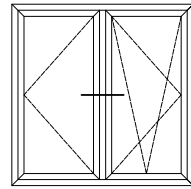

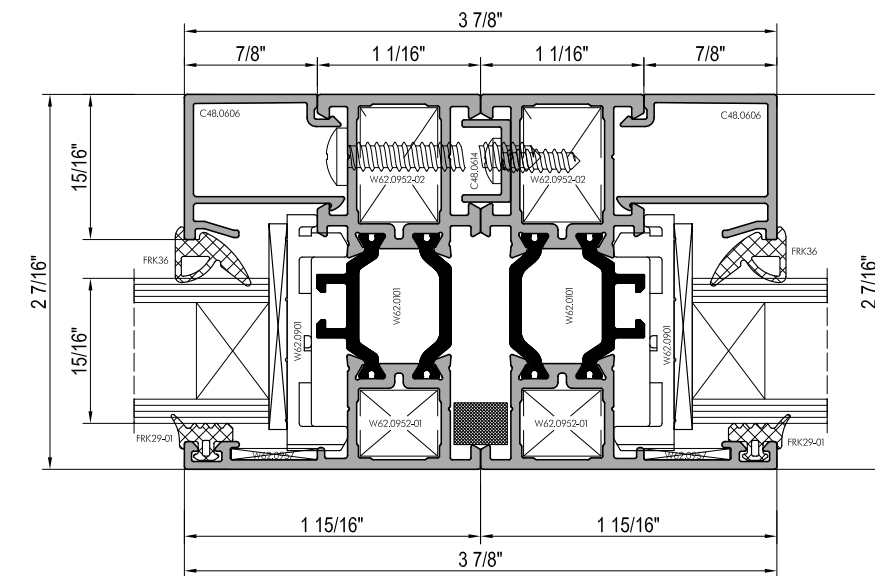
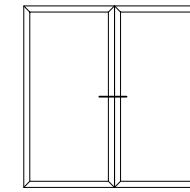
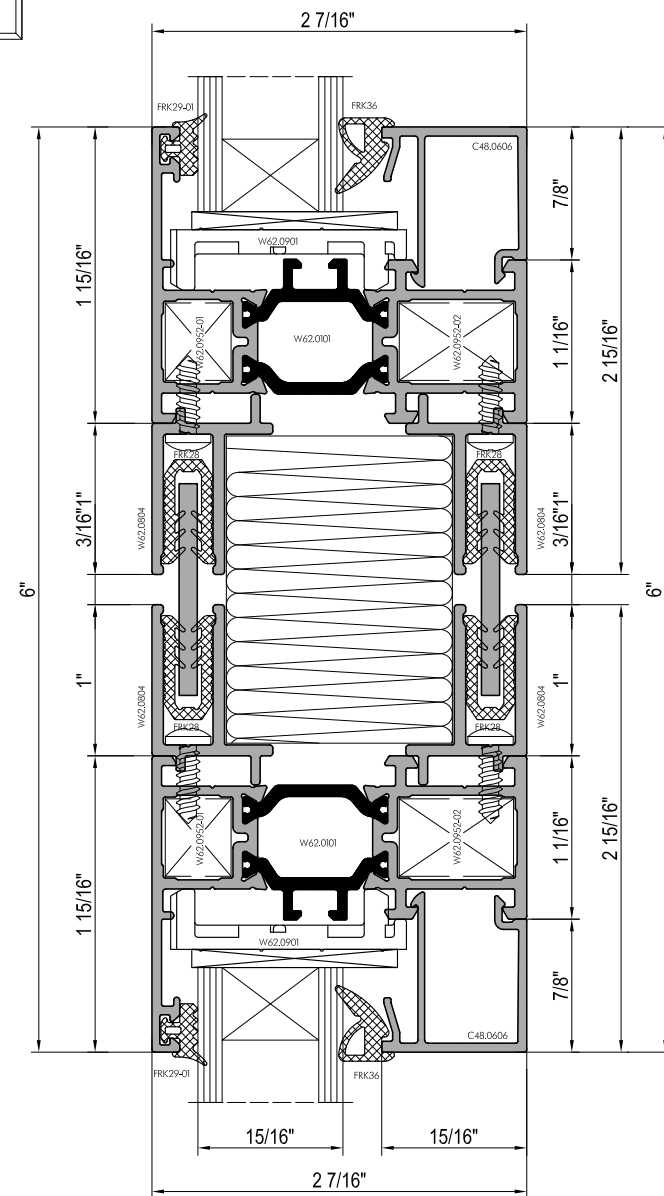
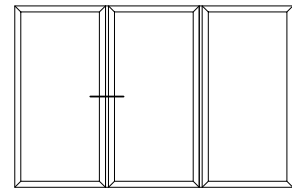

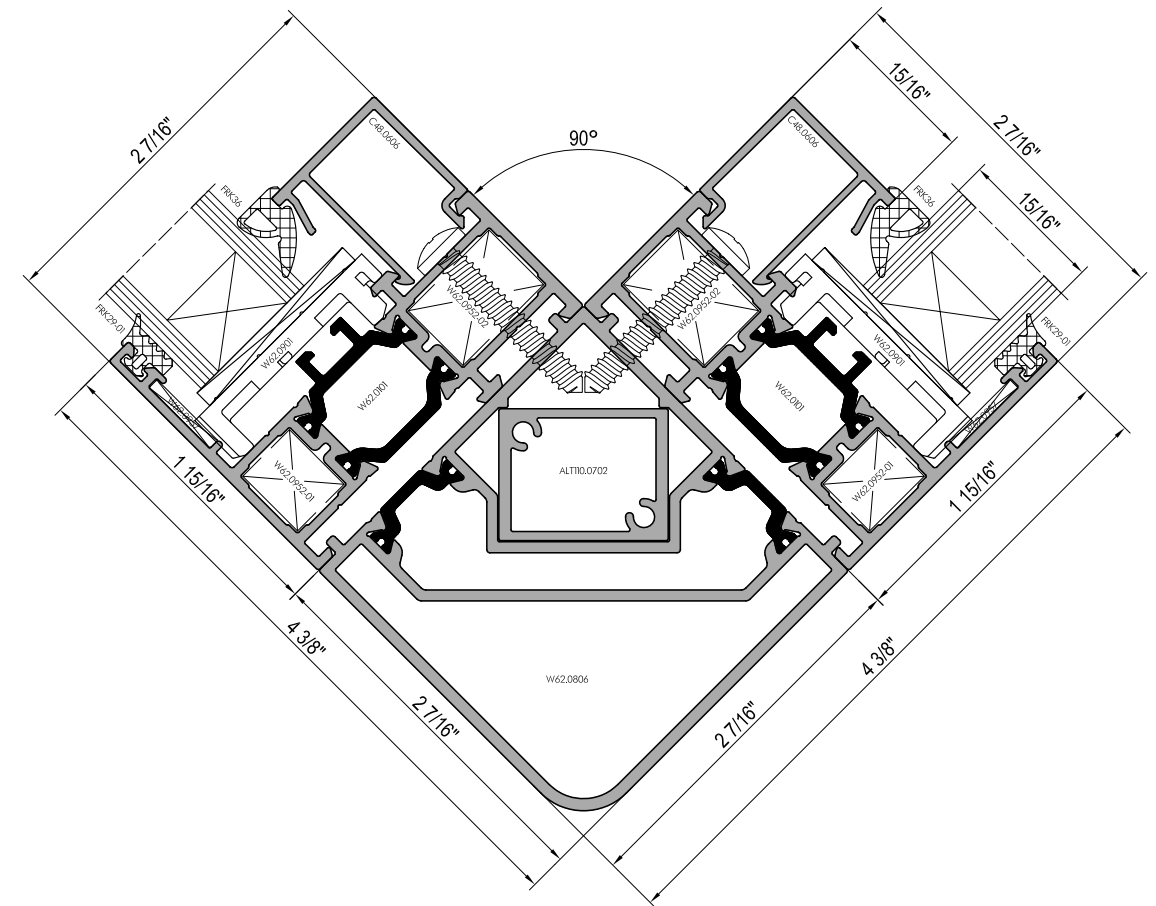
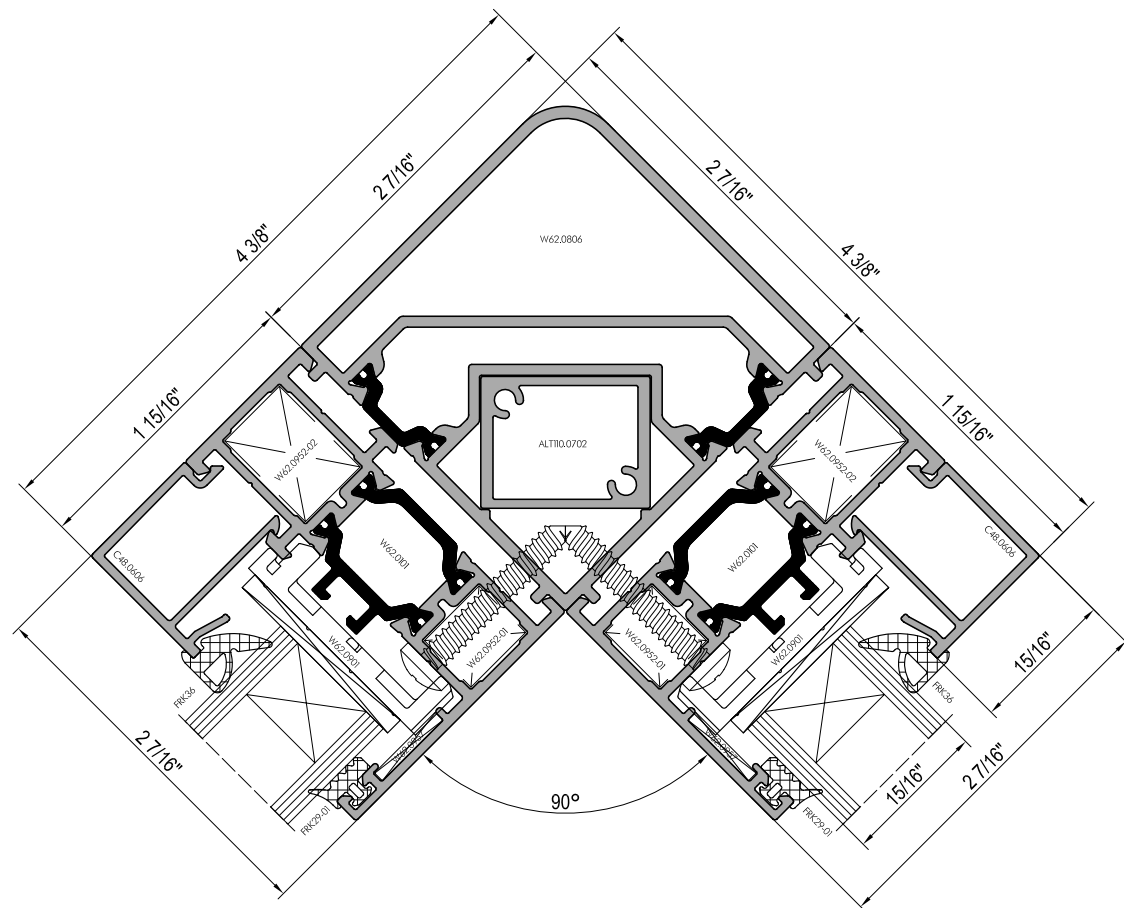
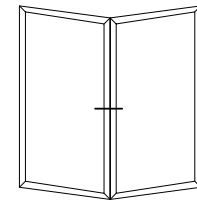
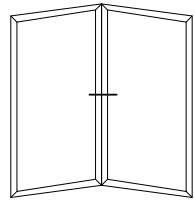

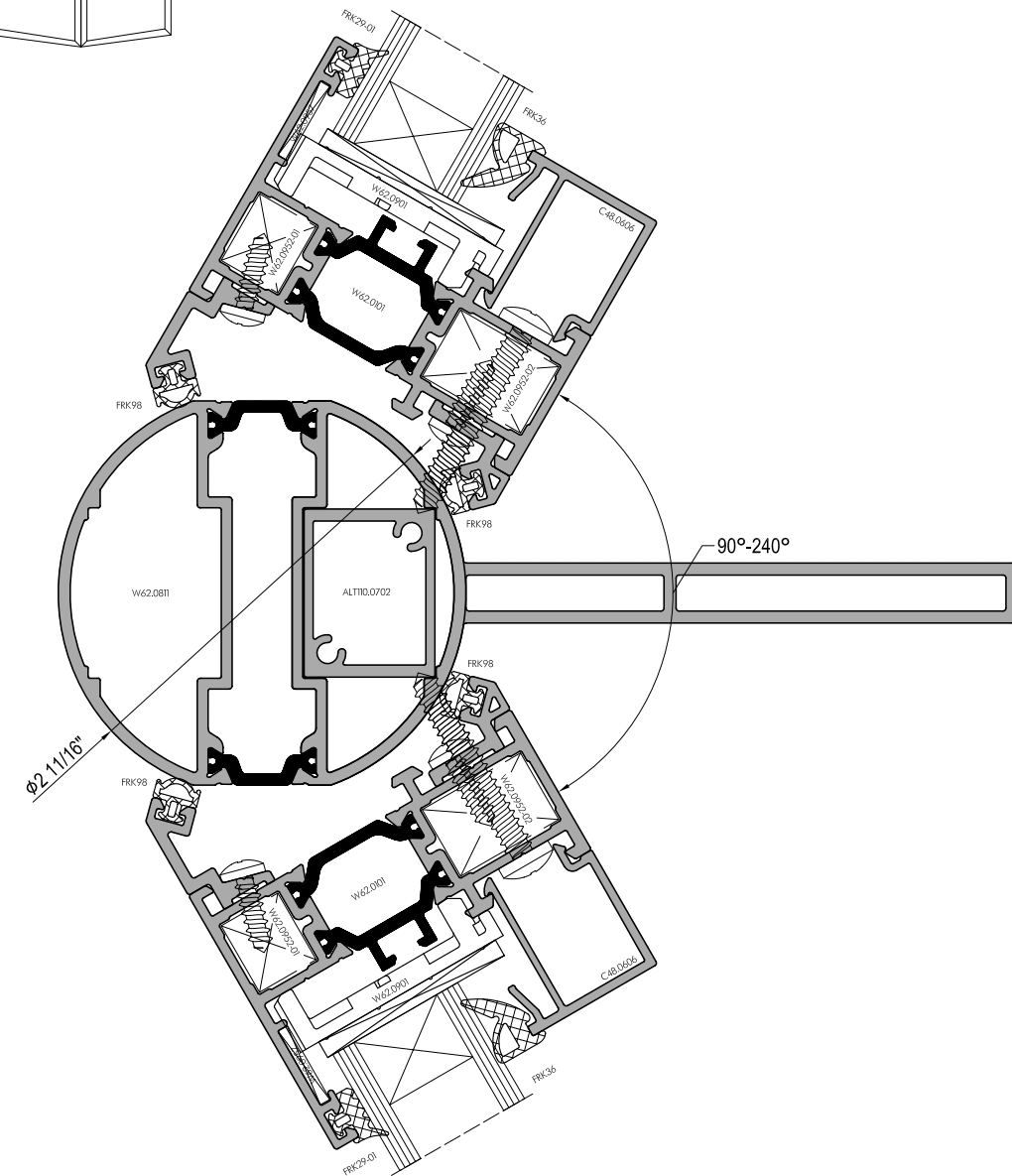
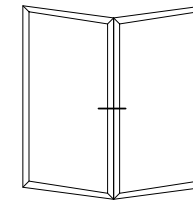
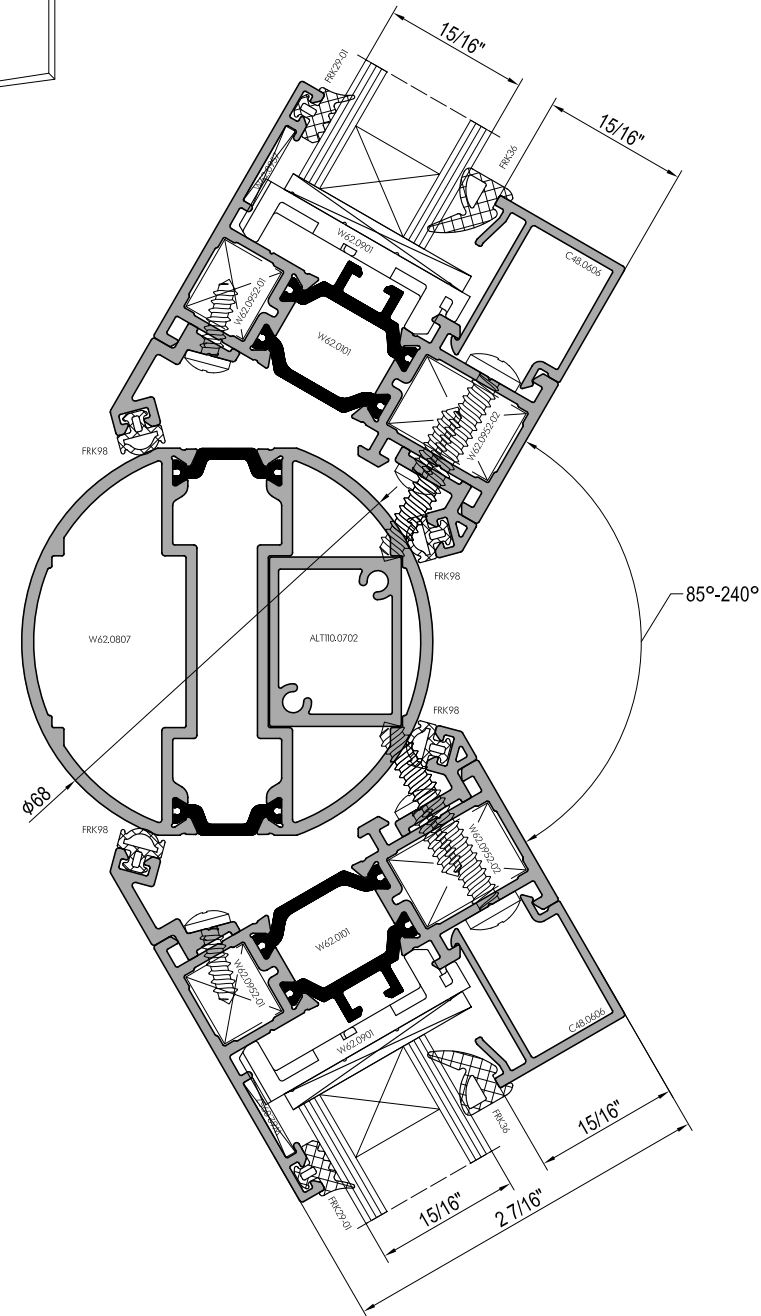
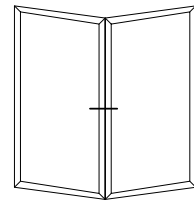

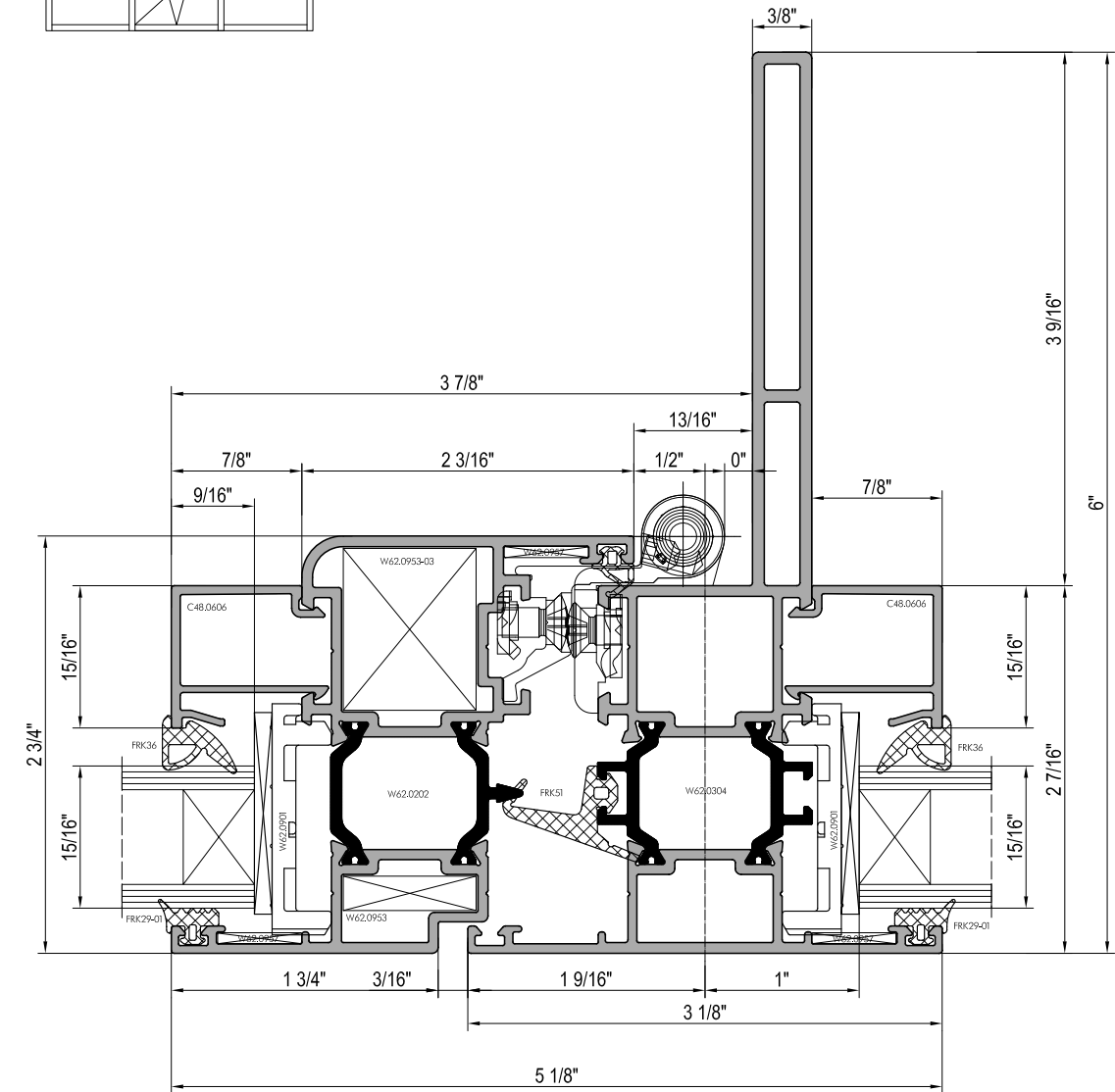
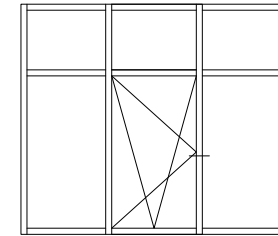
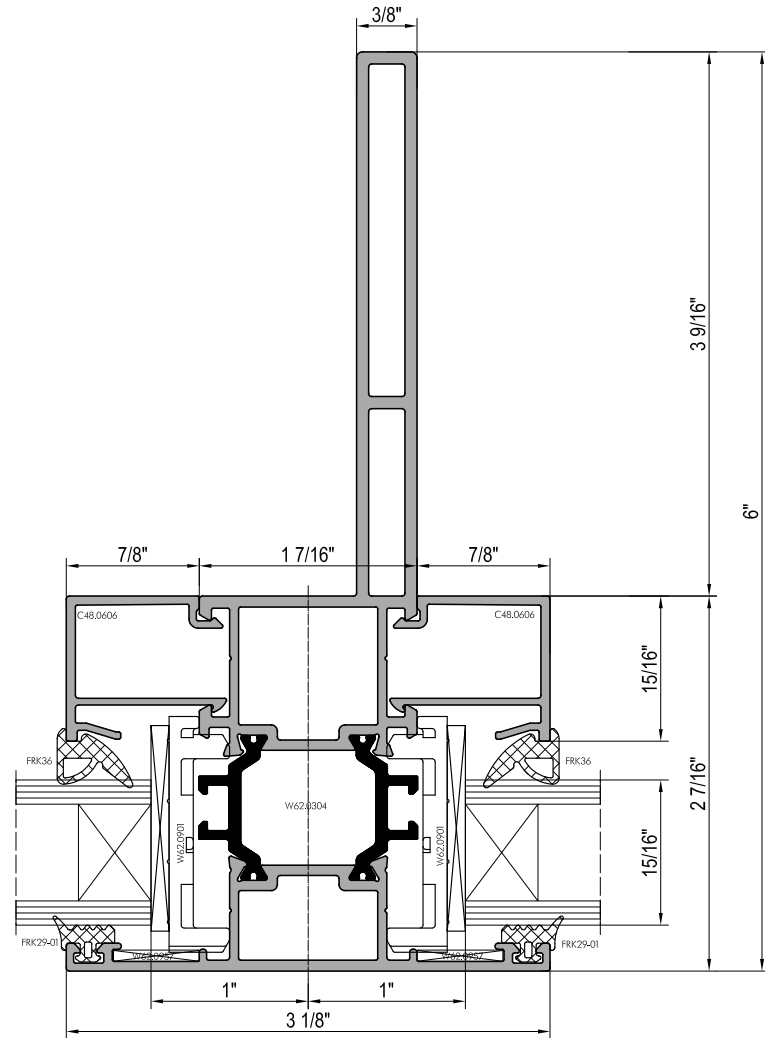
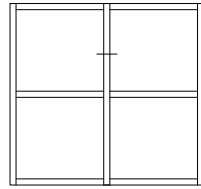

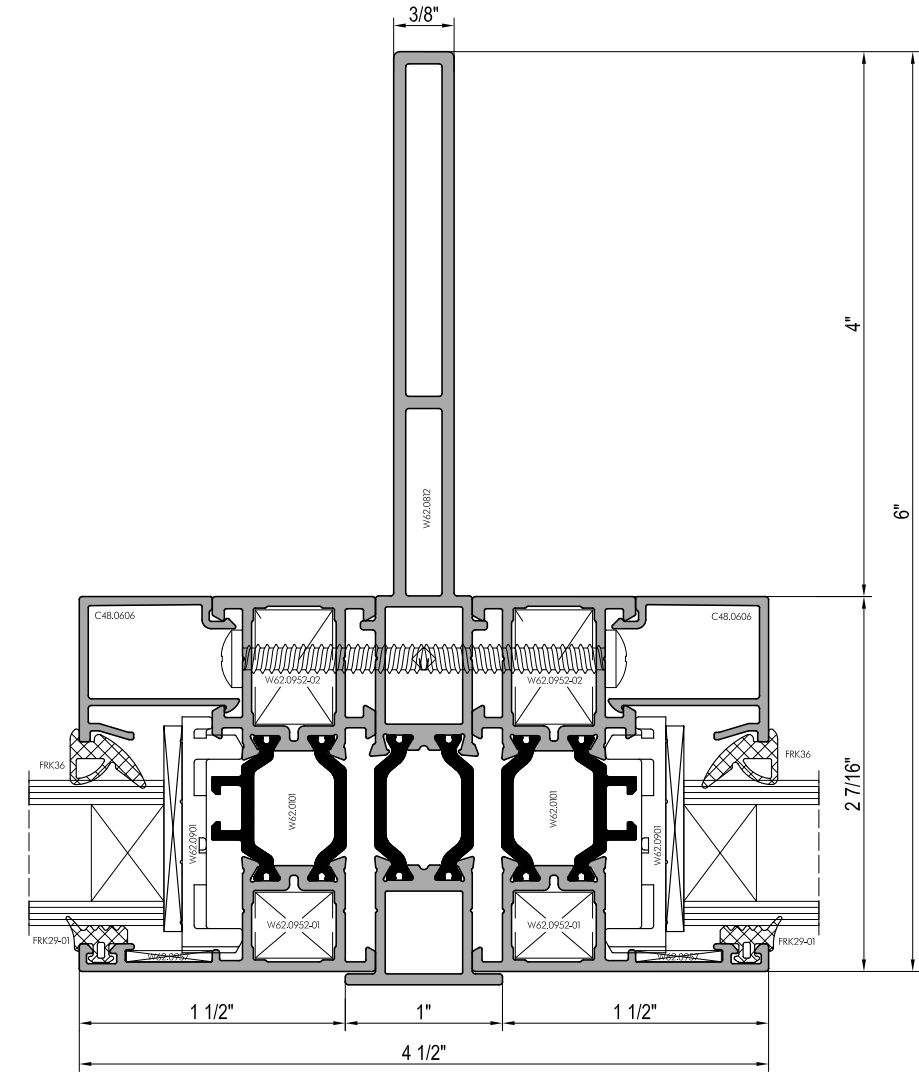
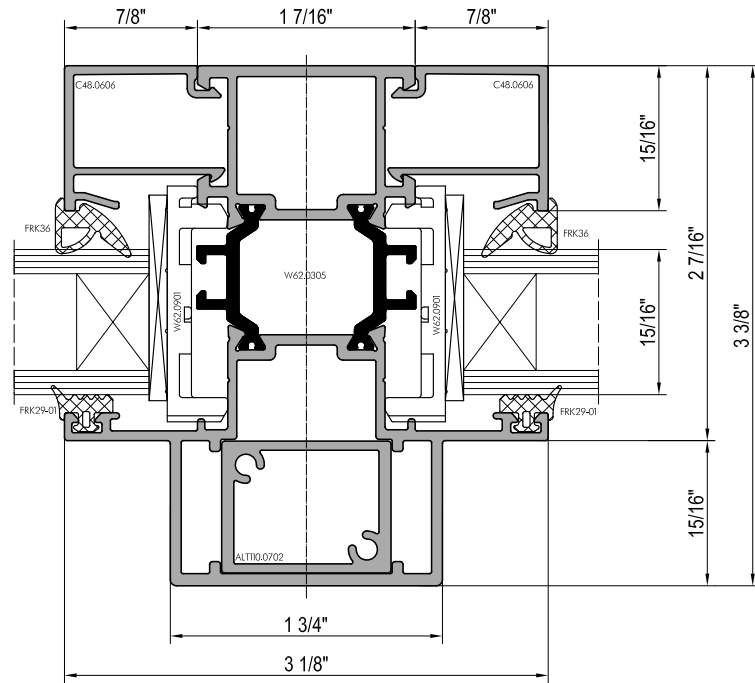
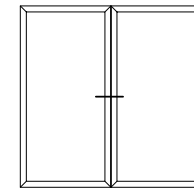
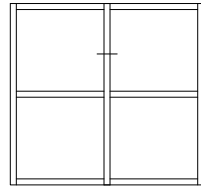

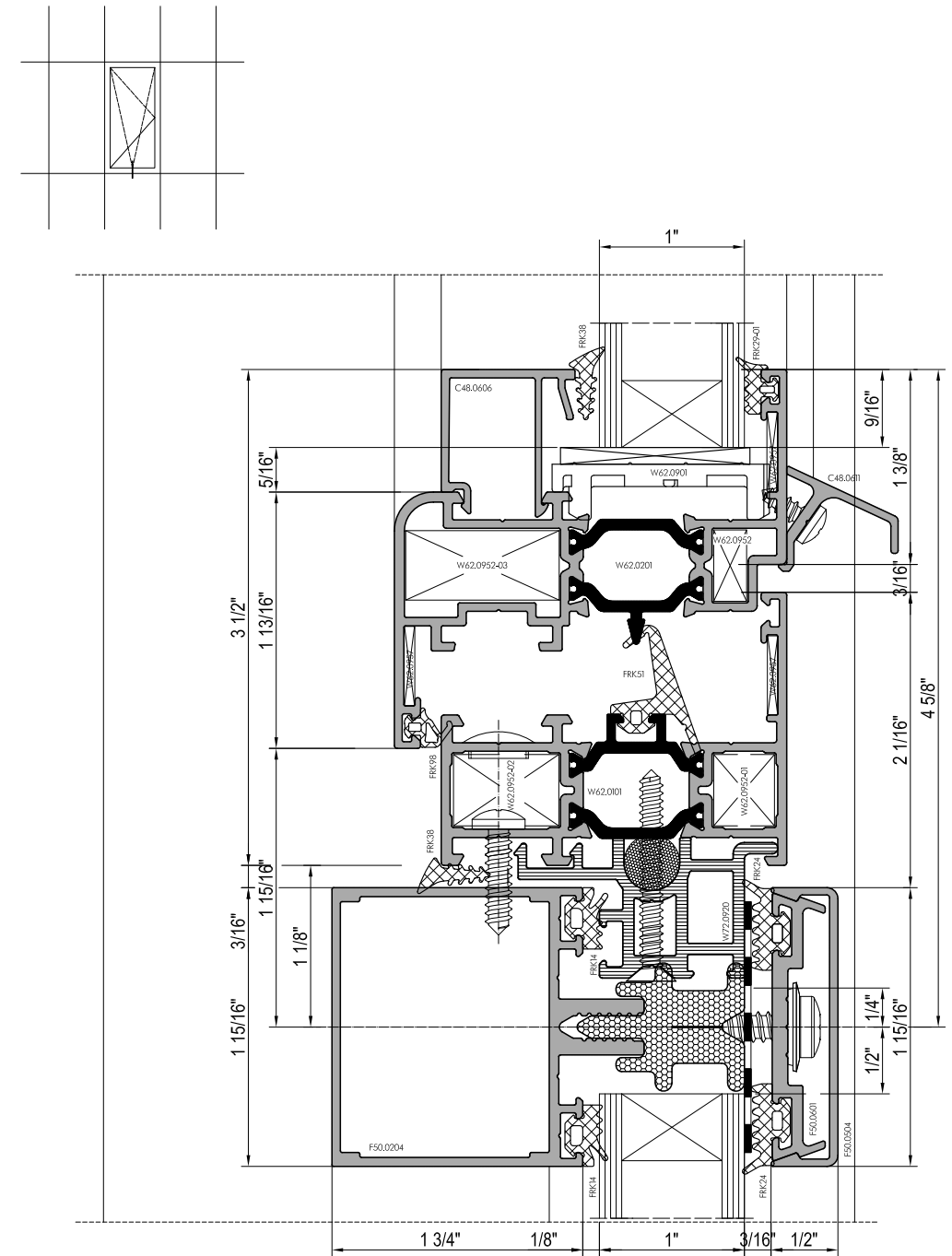
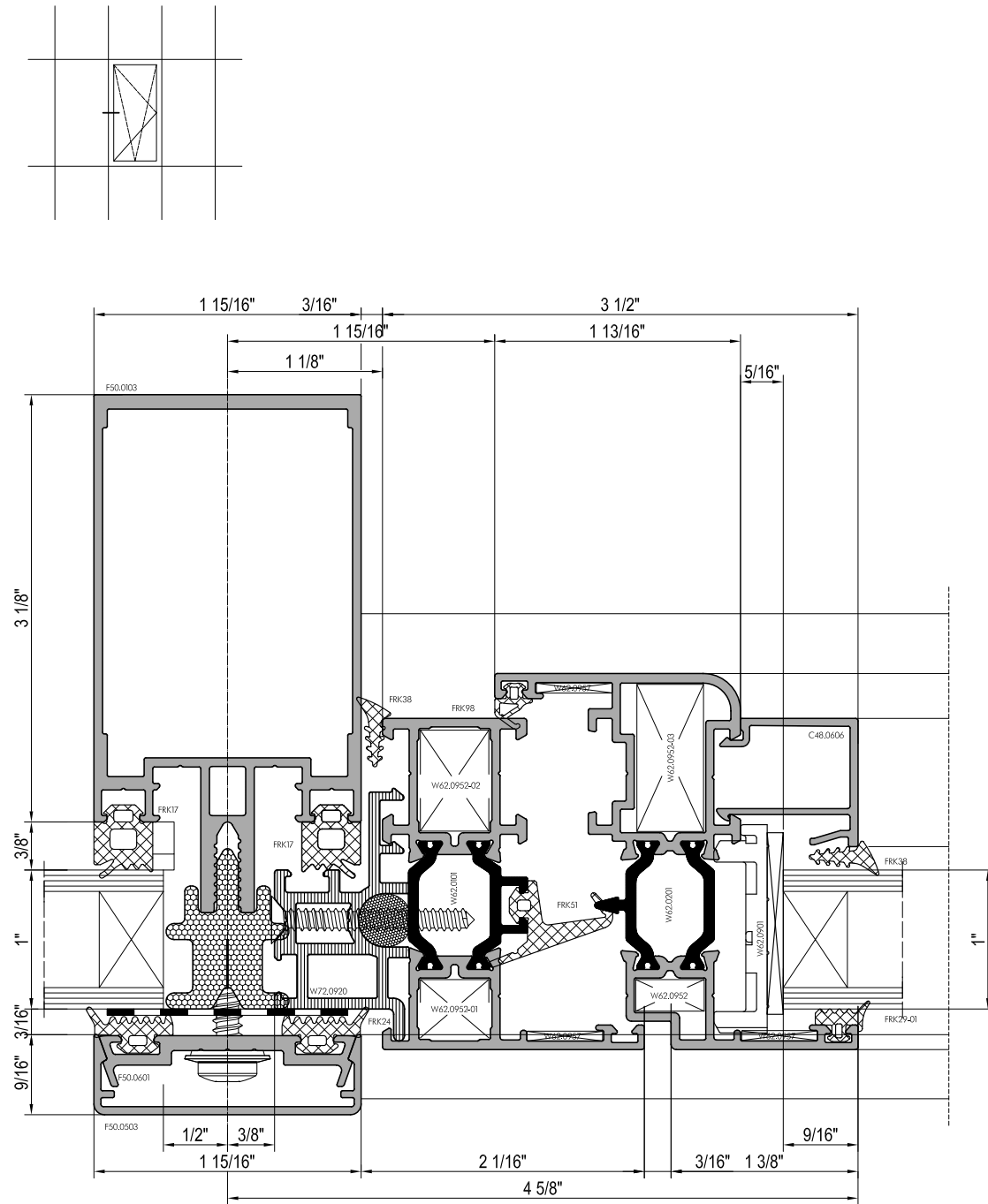

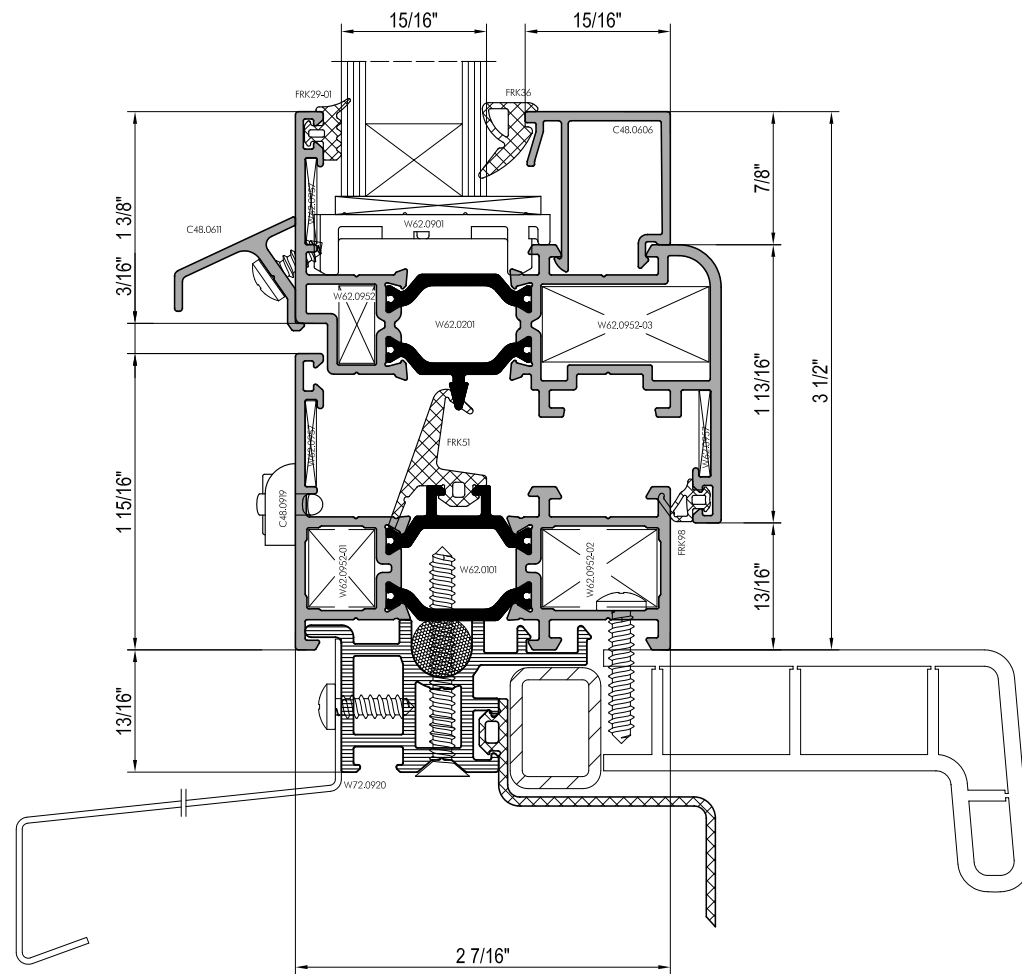
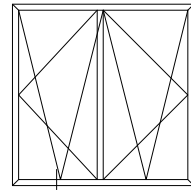

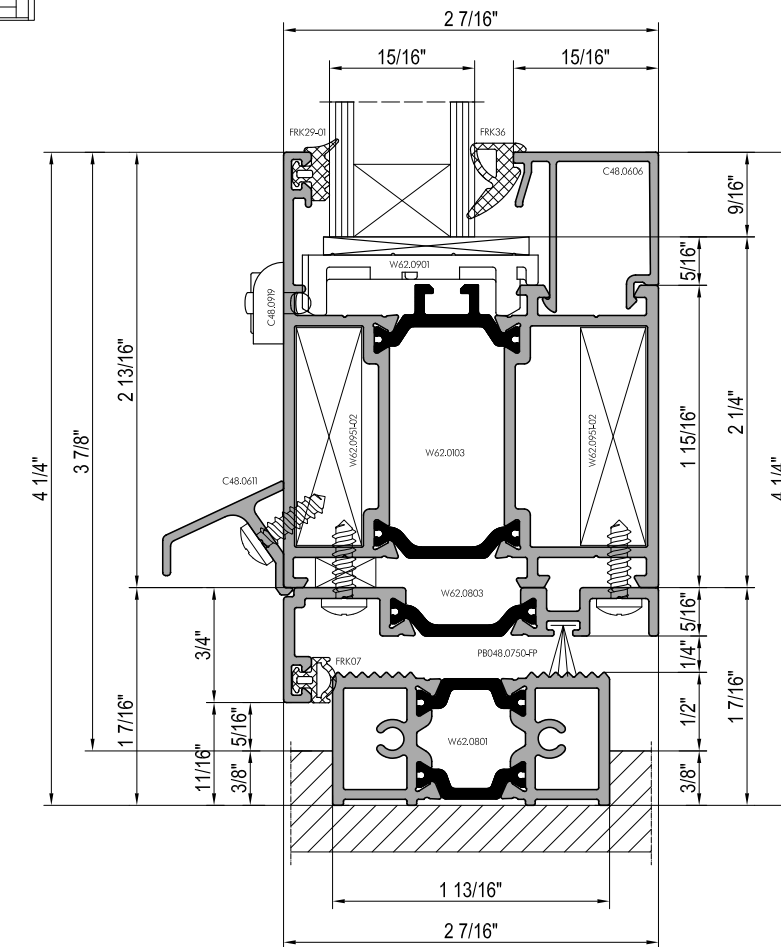
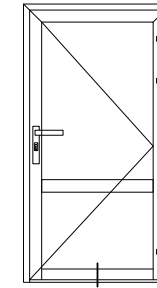
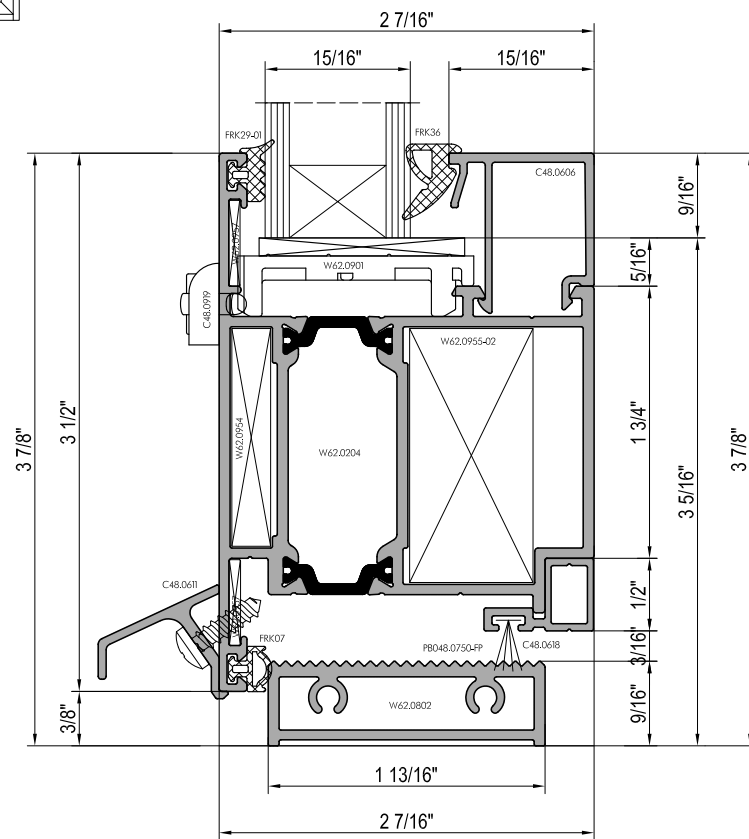
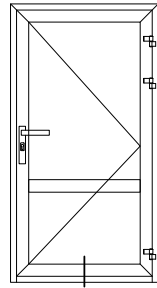

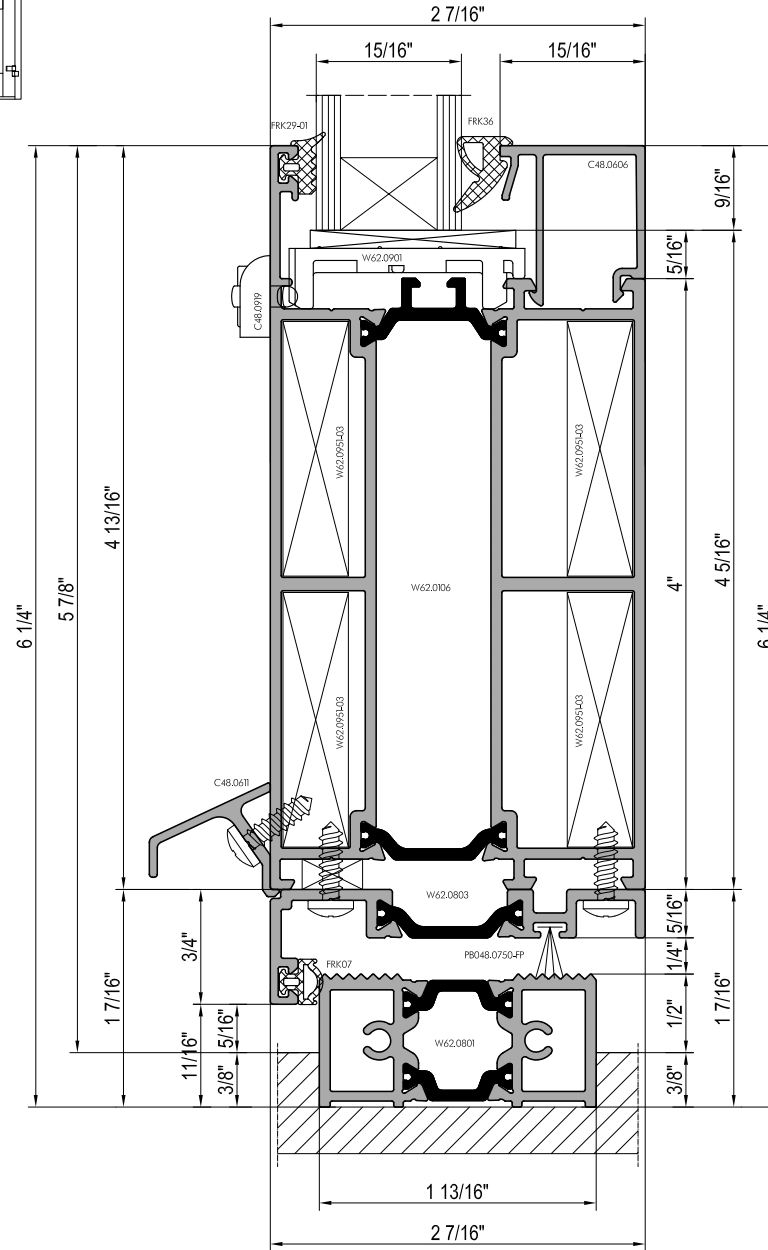
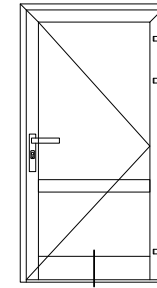
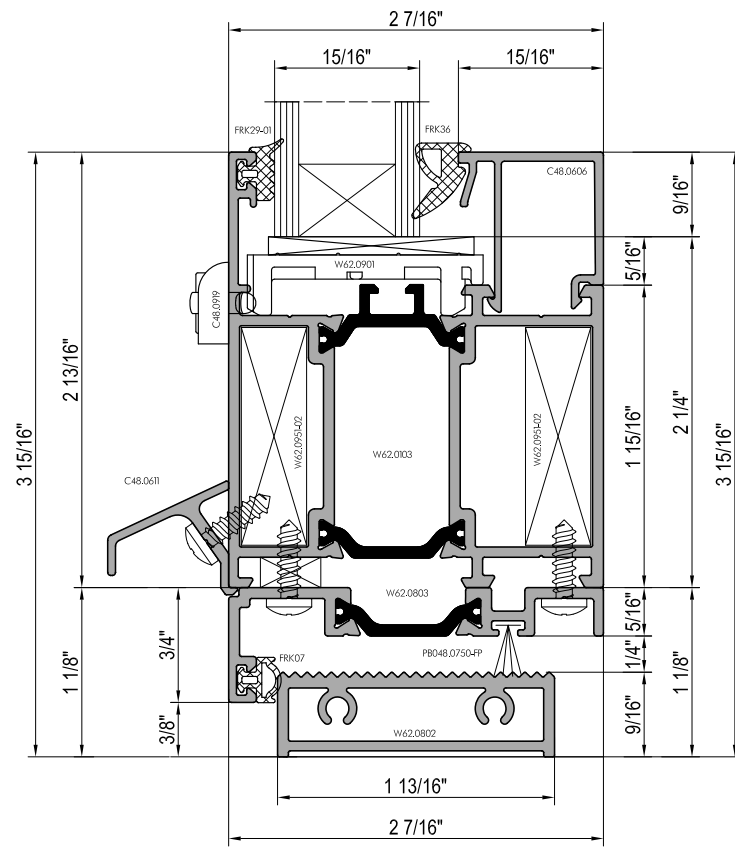
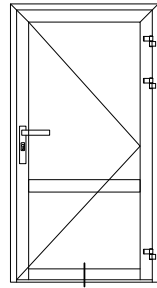

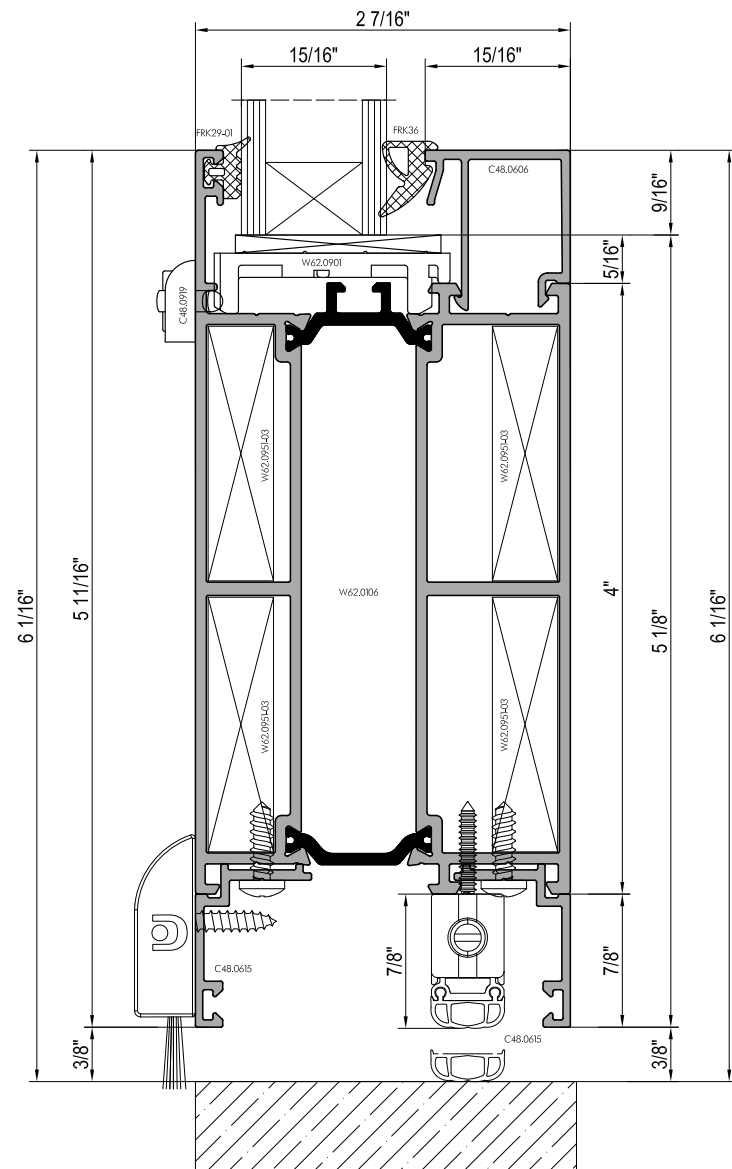
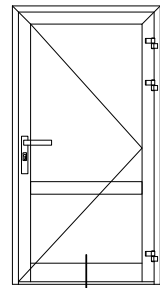

Automatic saddle option

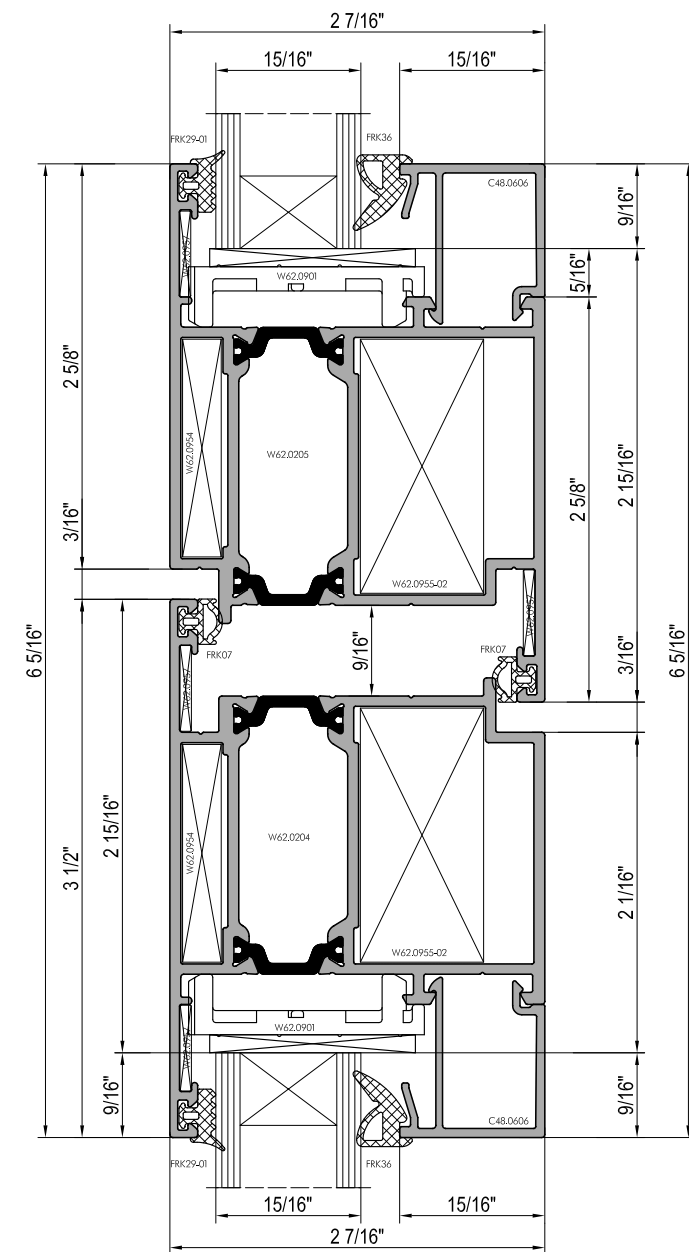
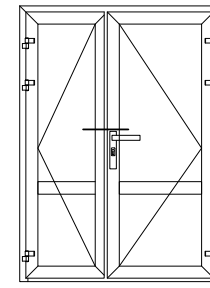

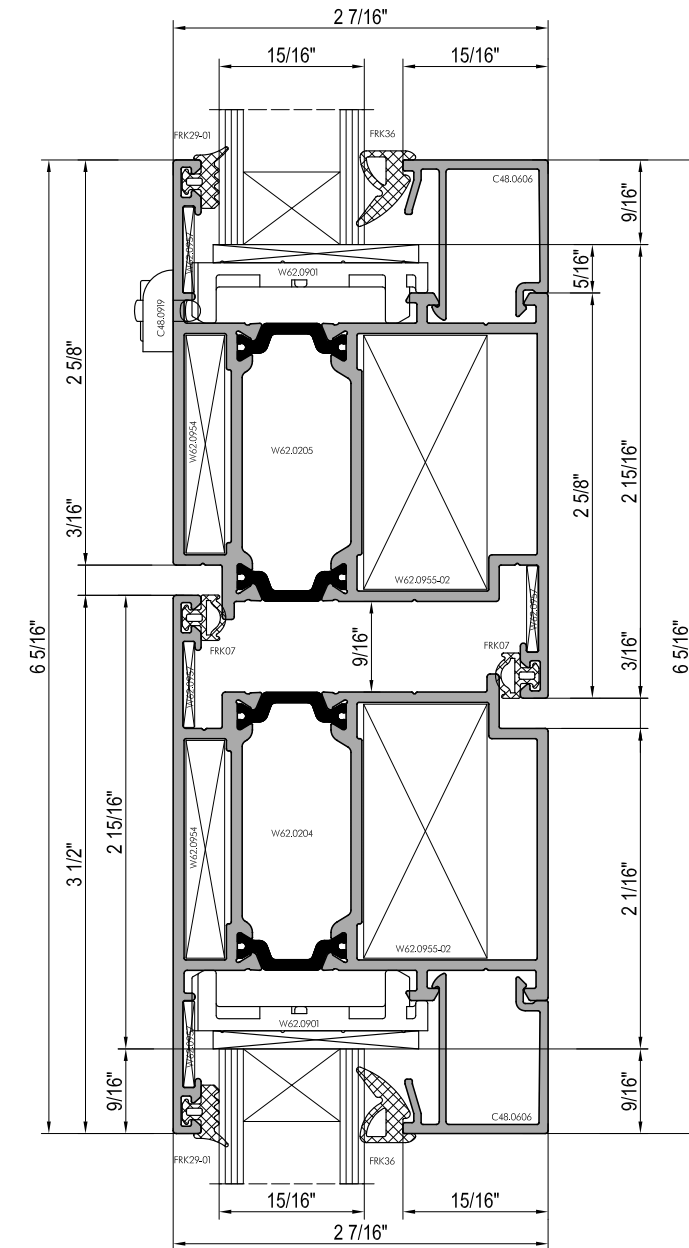
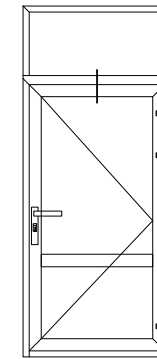
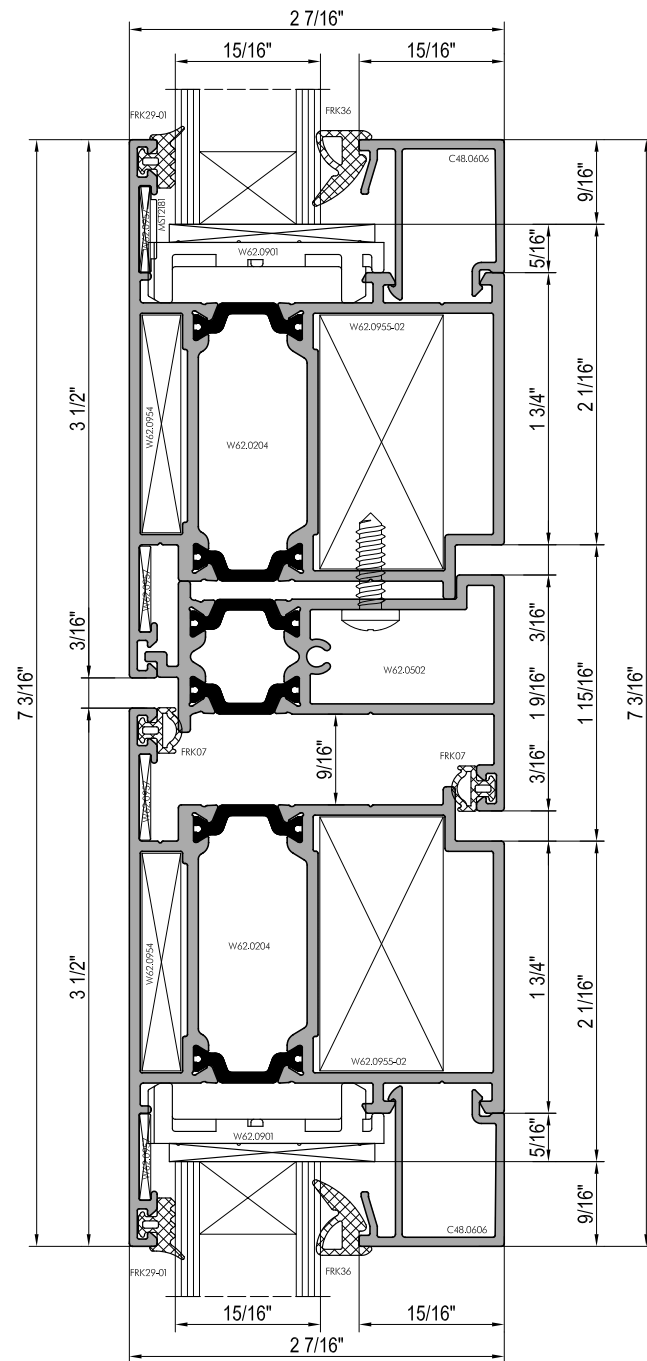
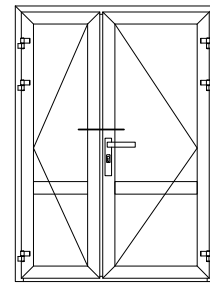

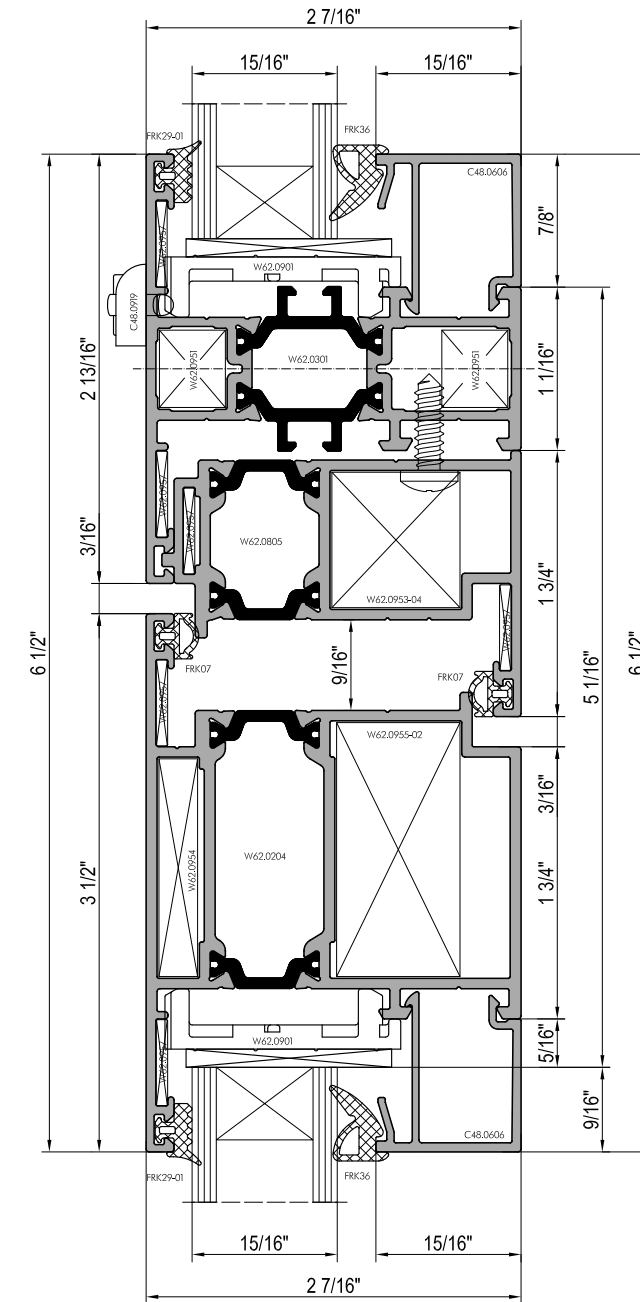
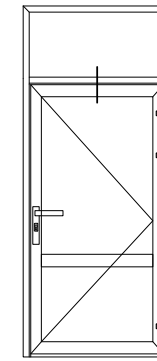
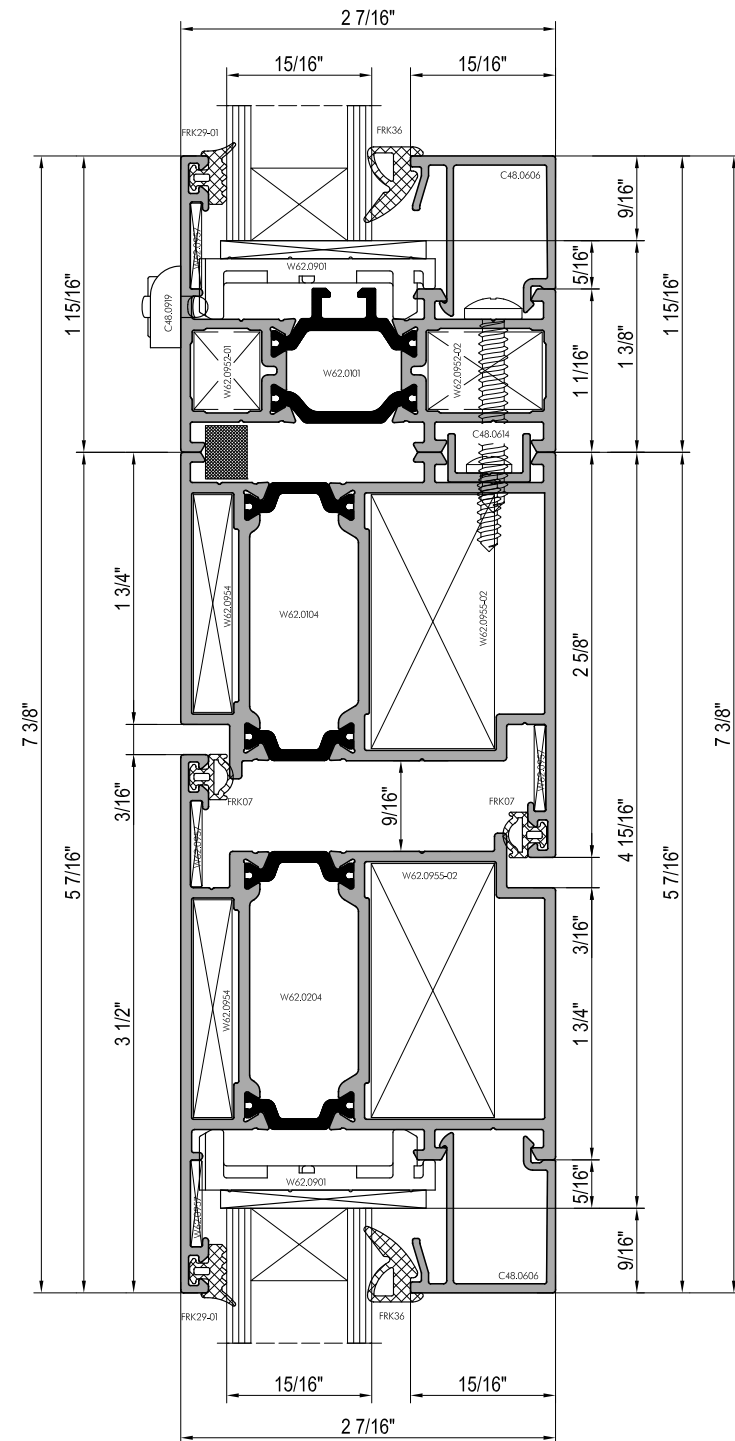
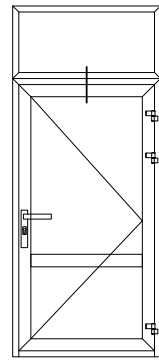

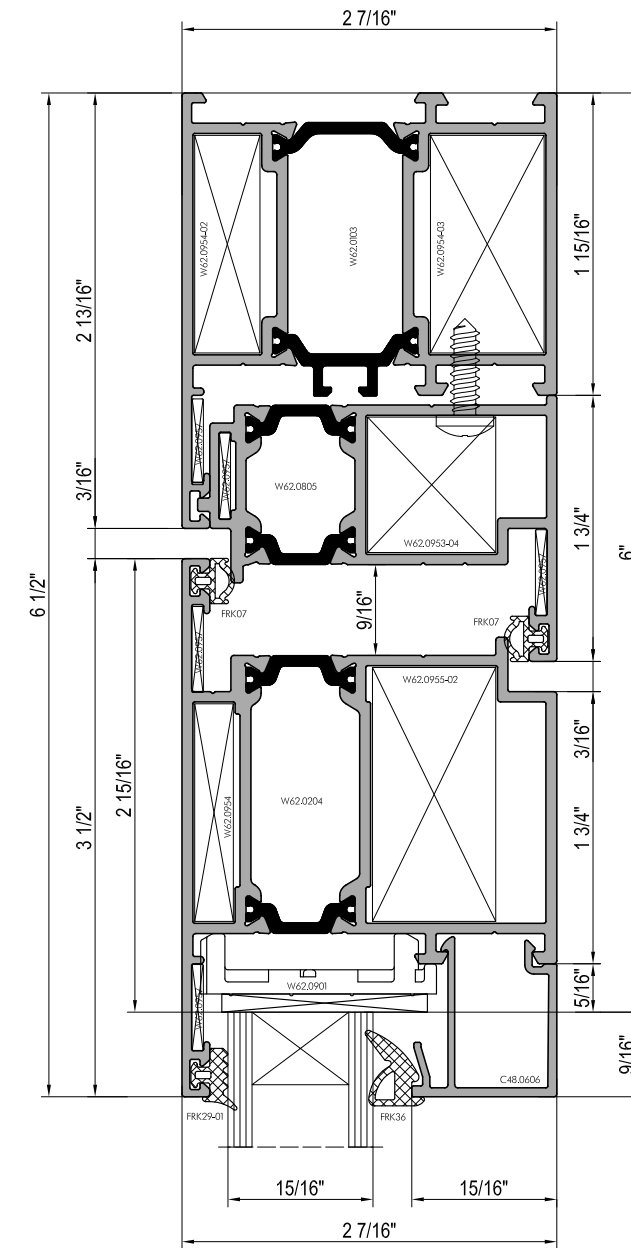
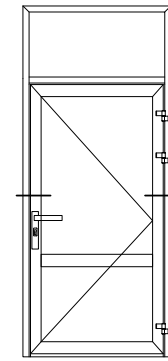
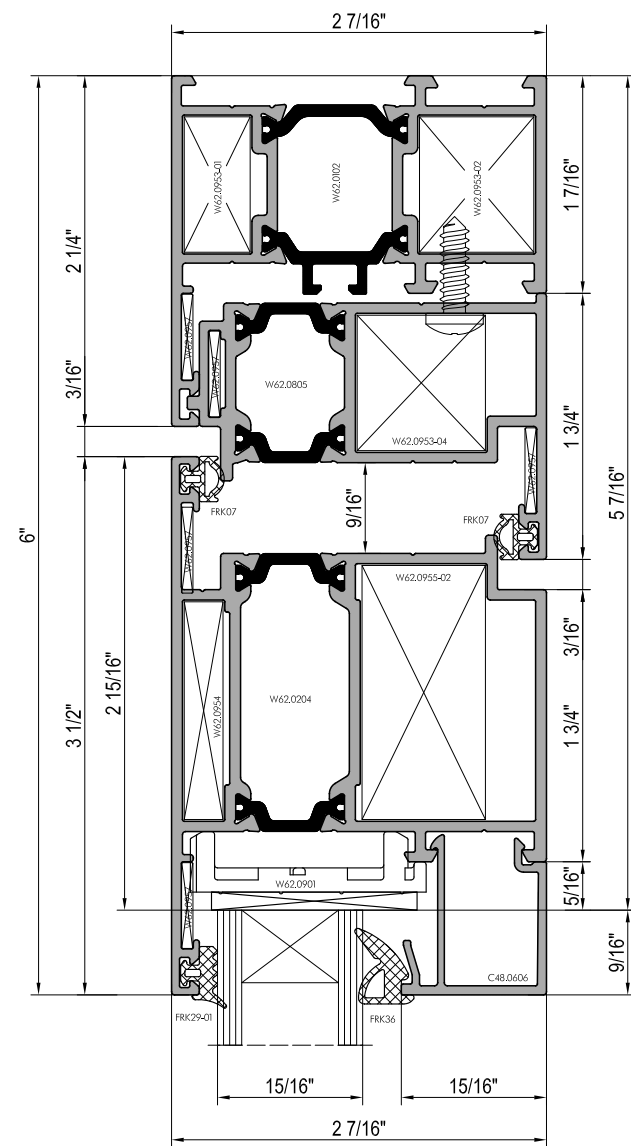
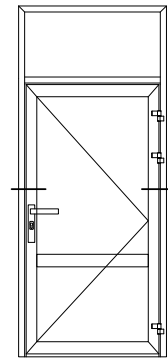

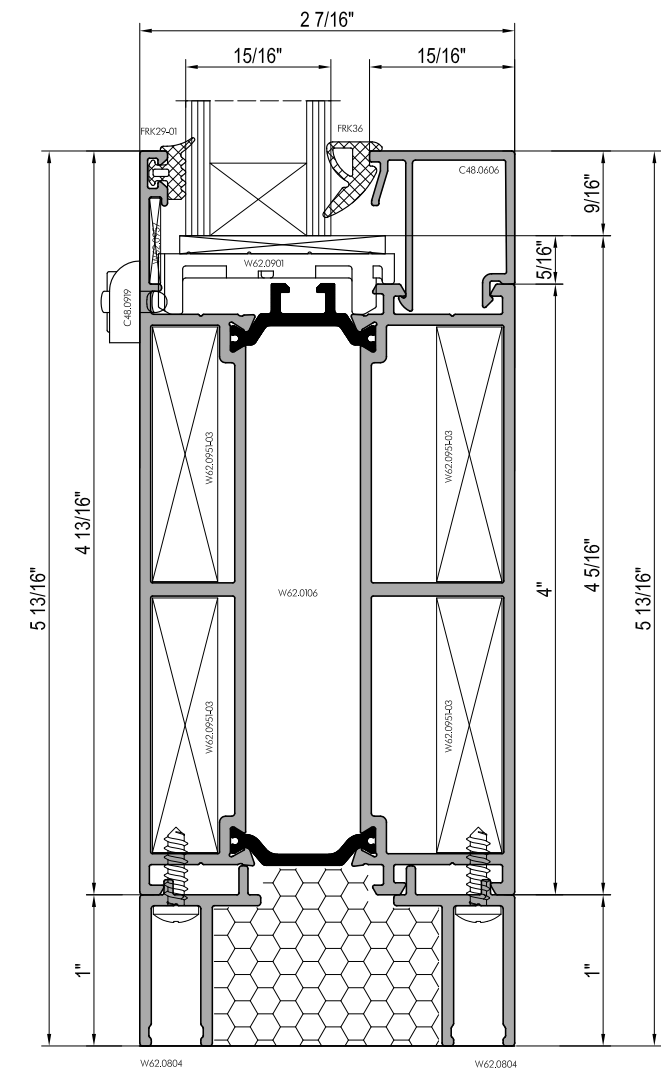
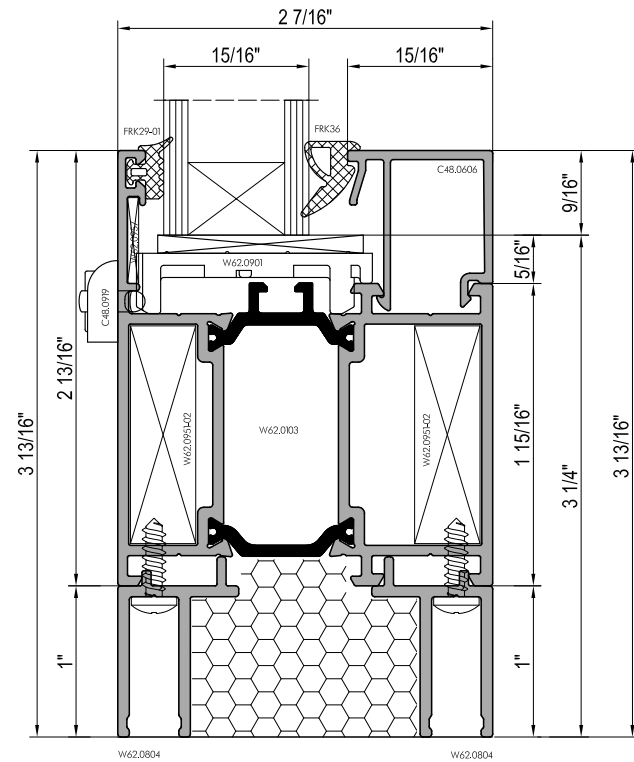
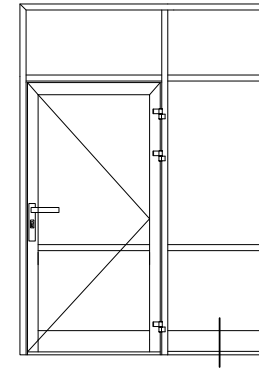
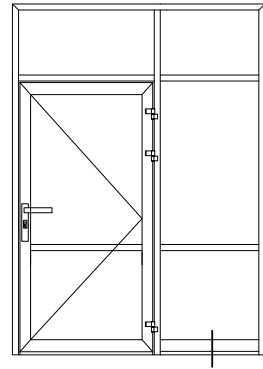

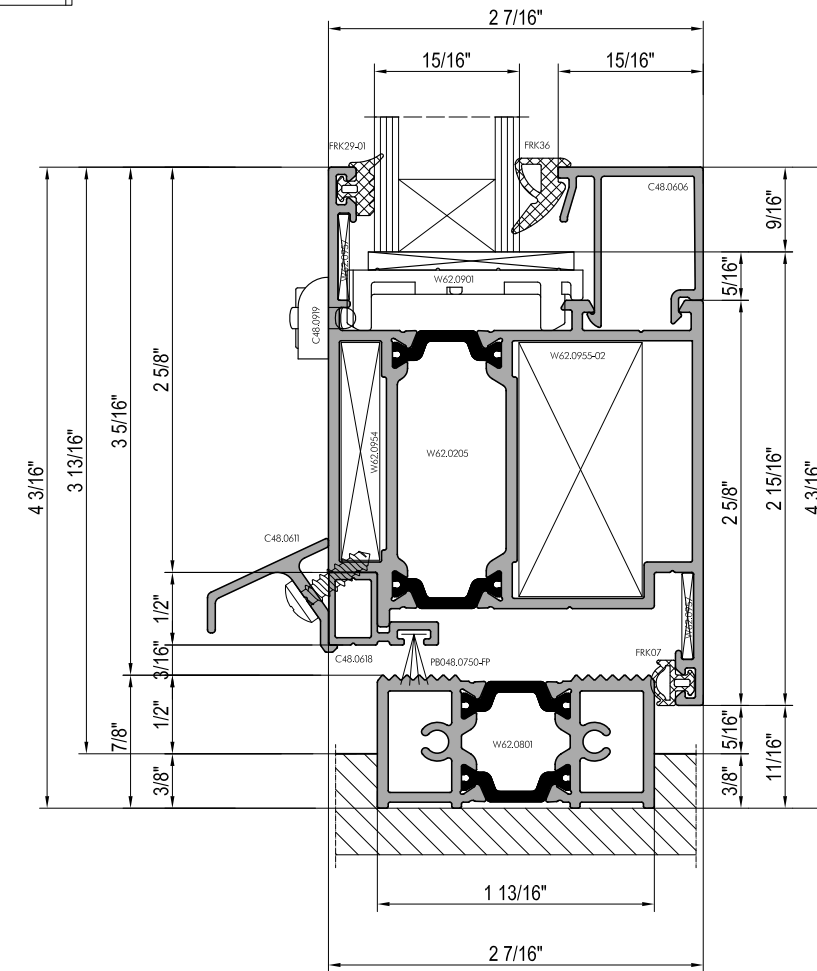
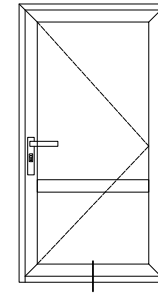
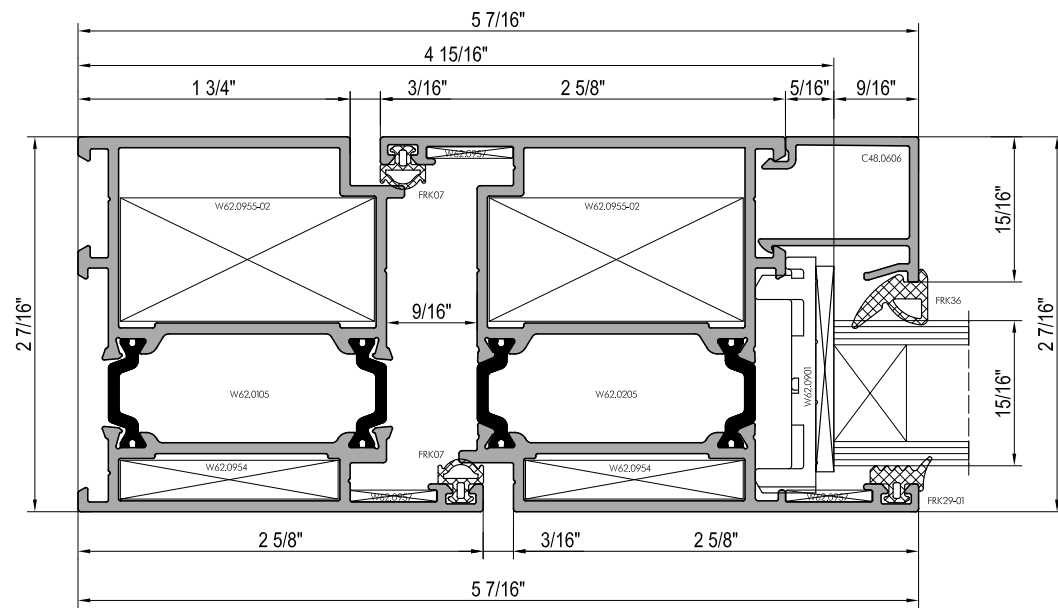
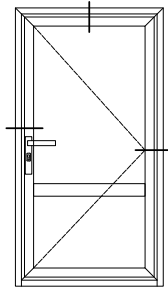

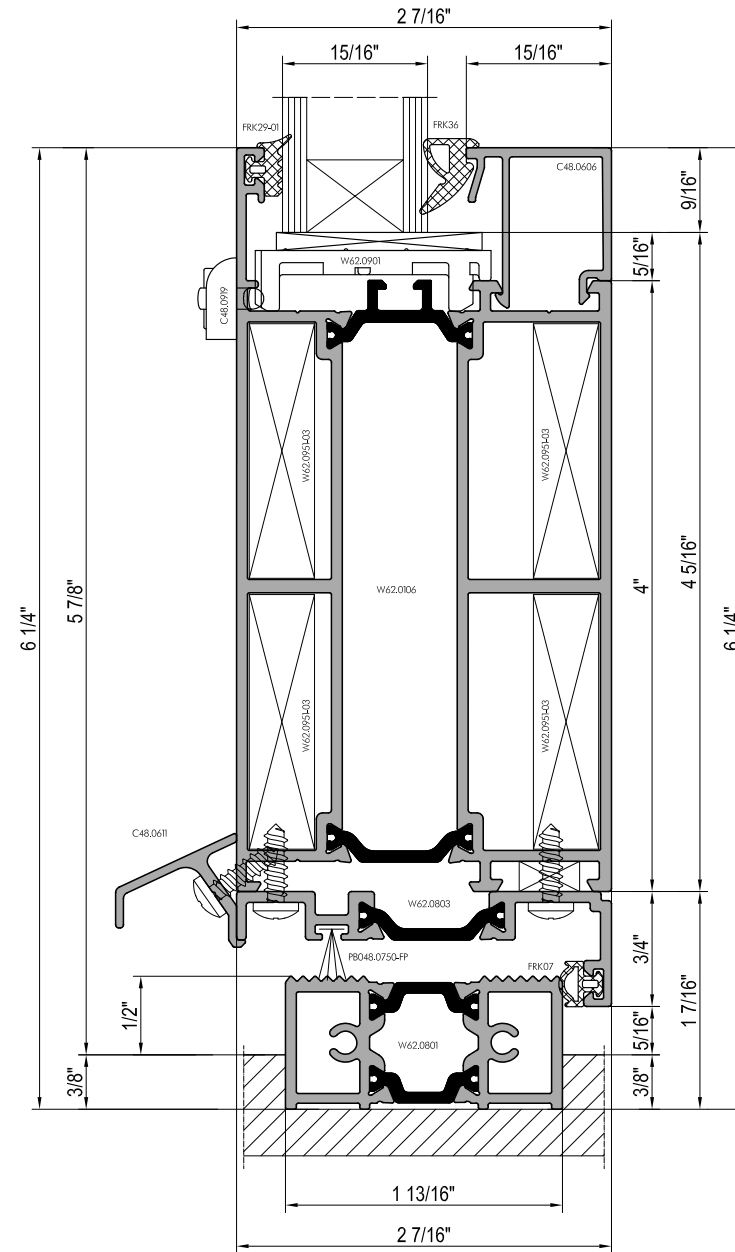
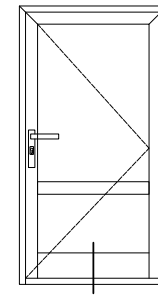
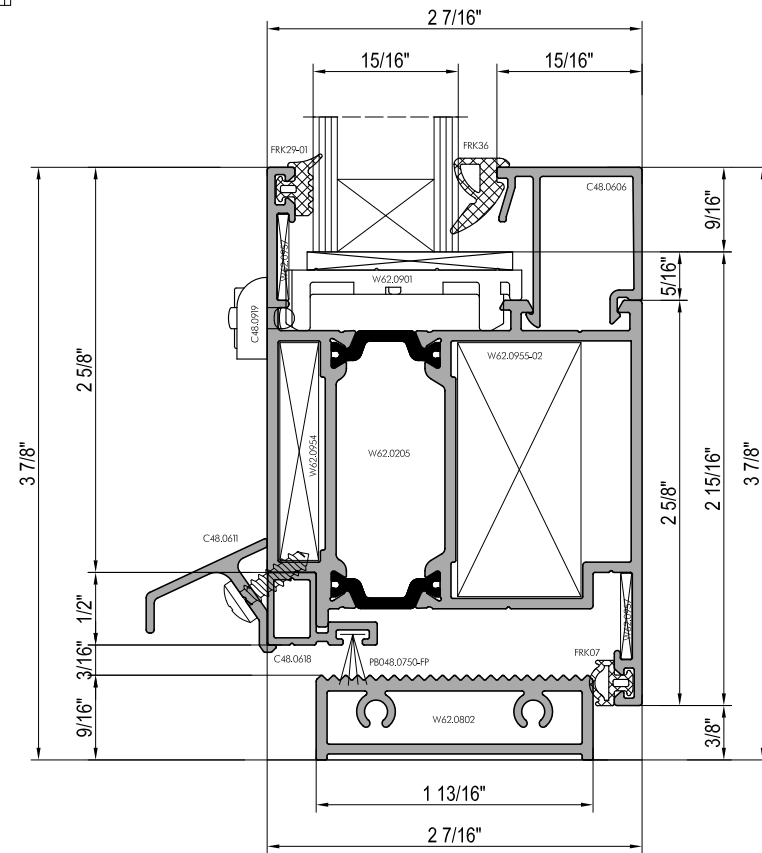
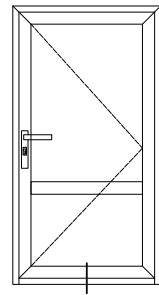

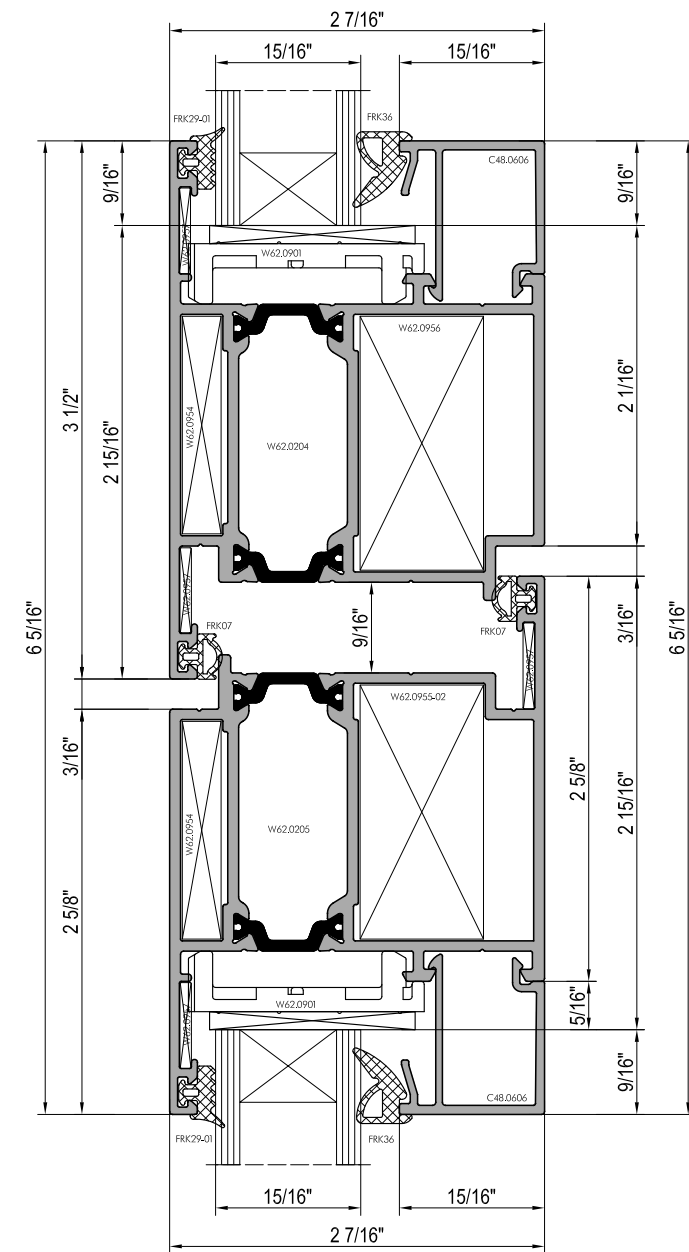
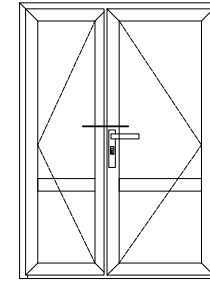
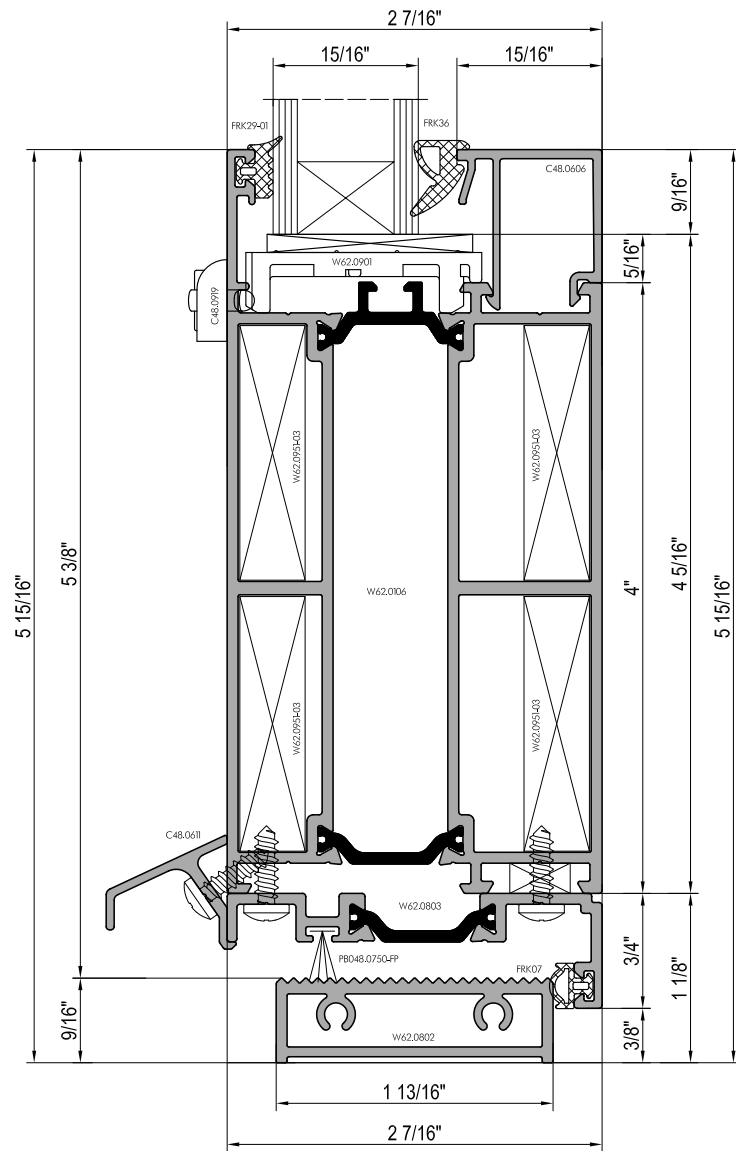
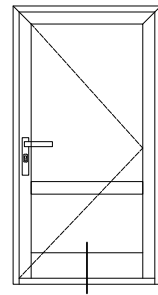

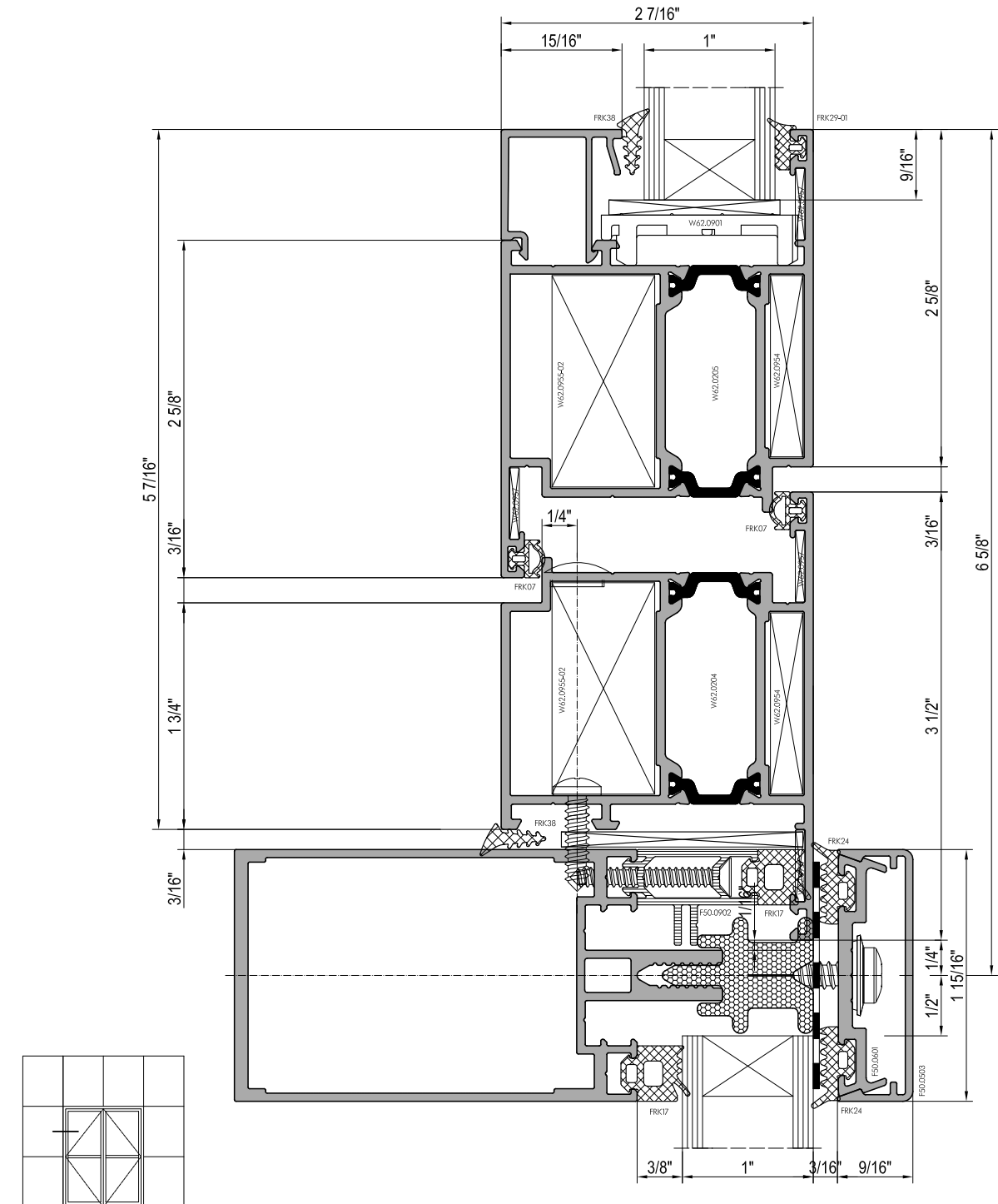
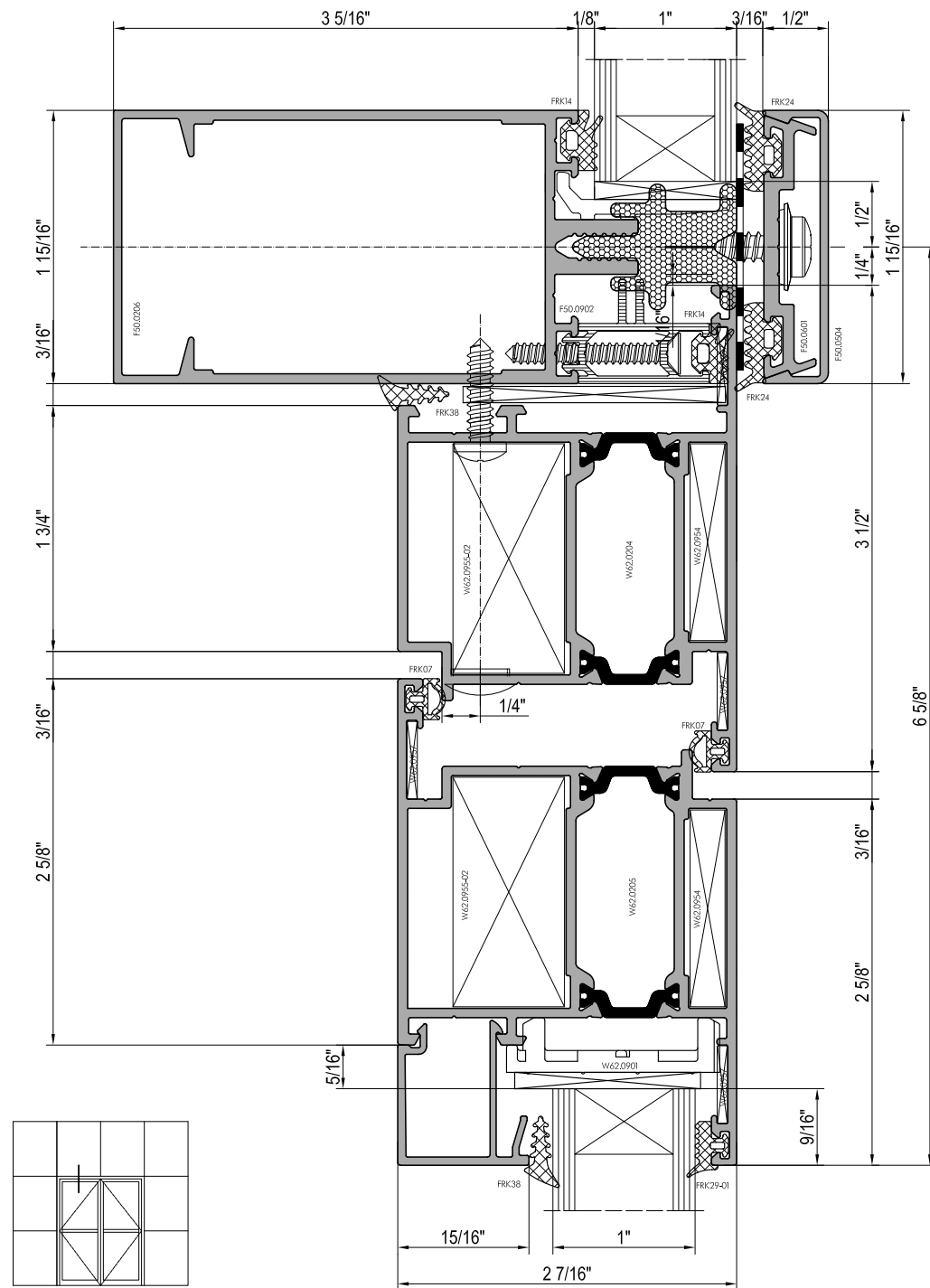

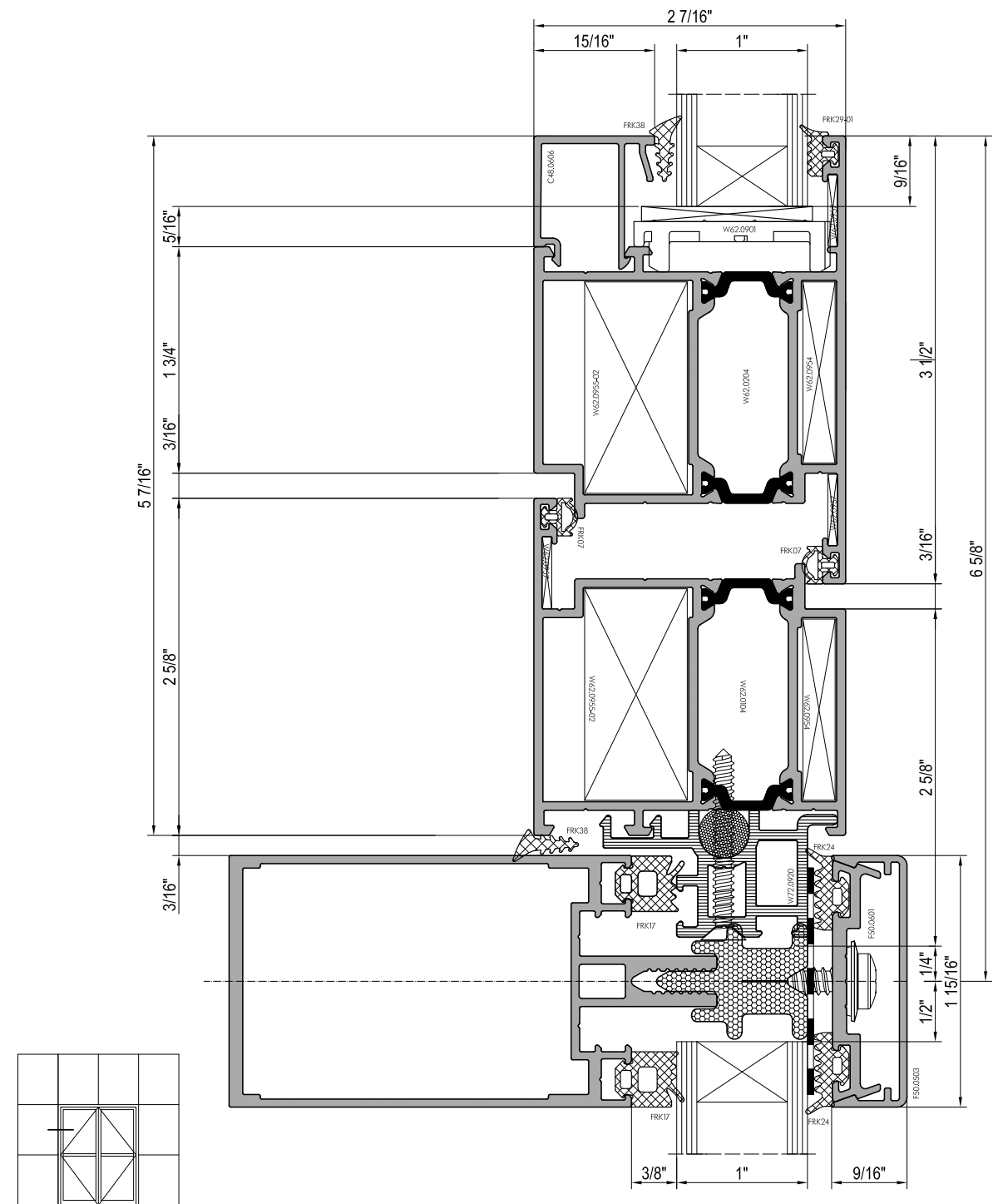
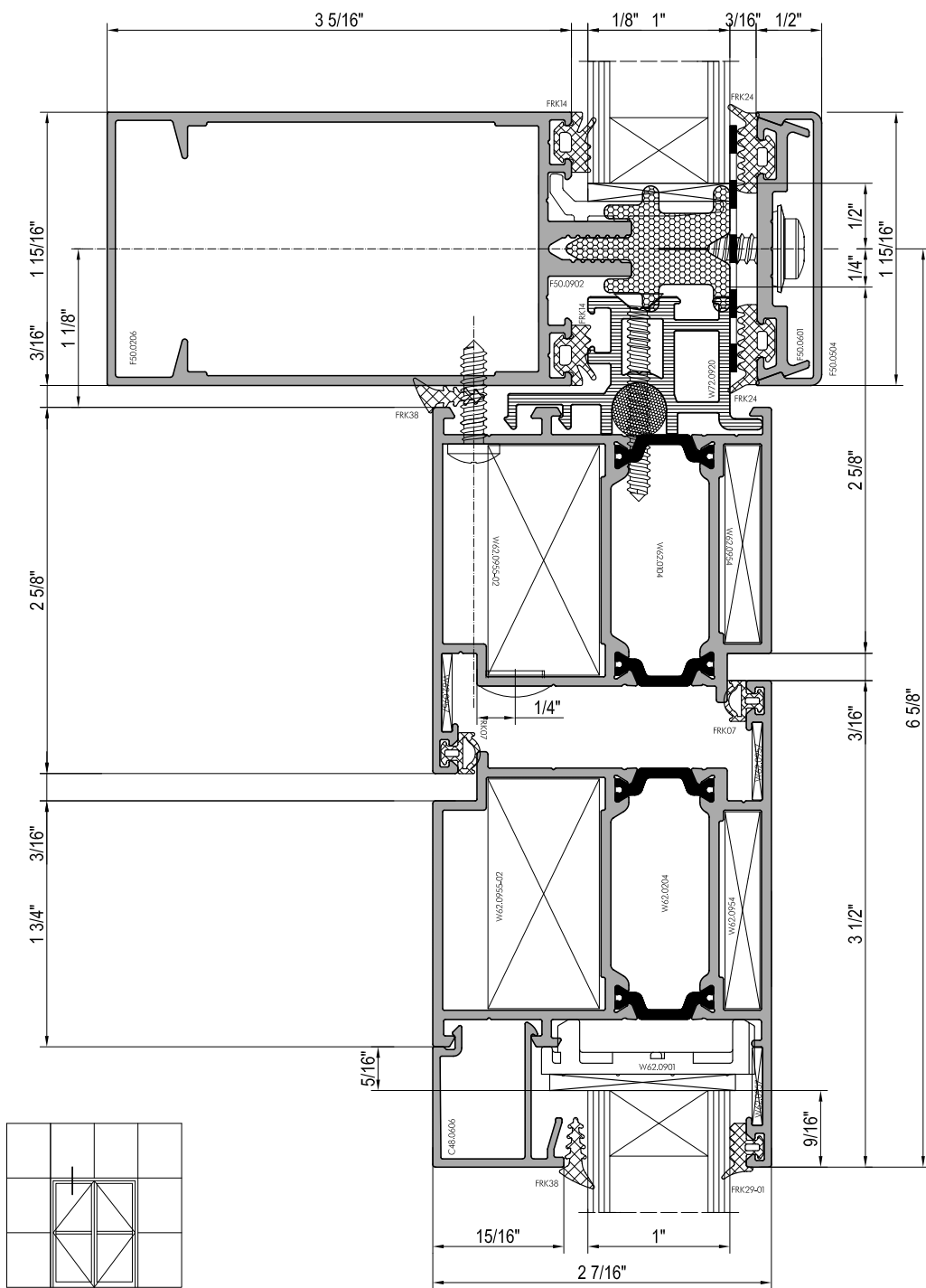

TYPICAL ASSEMBLY INSTRUCTIONS

Corner key installation in W62.0101 moldings using crimping machine

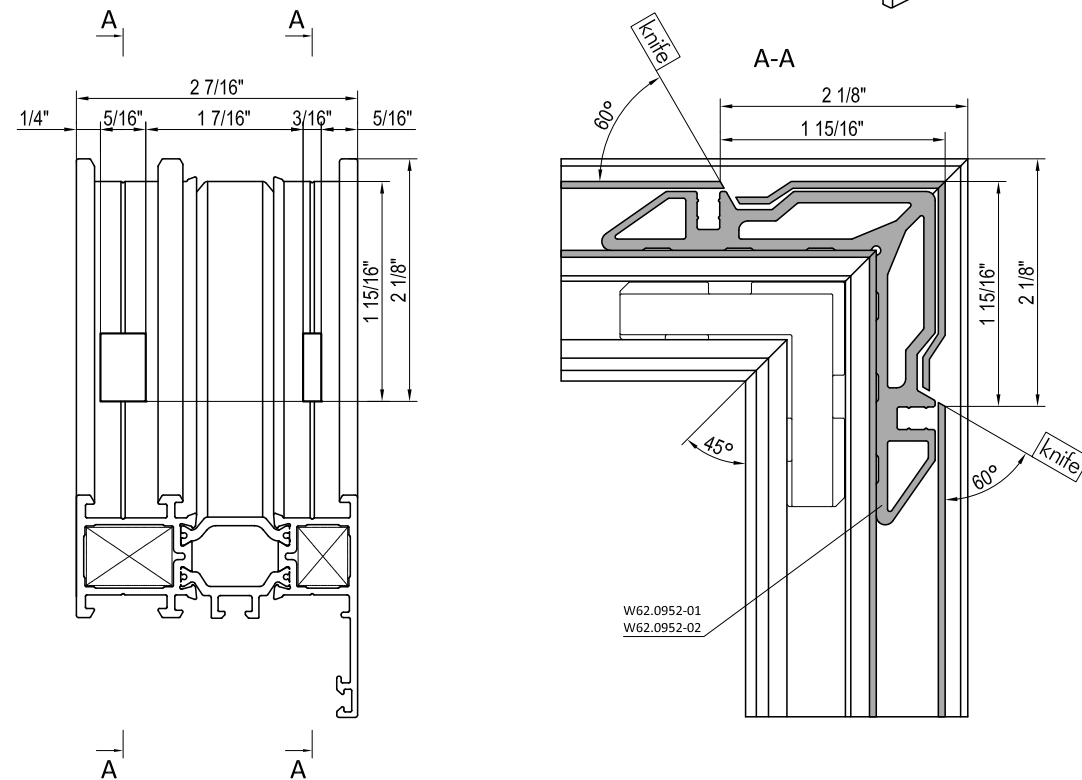
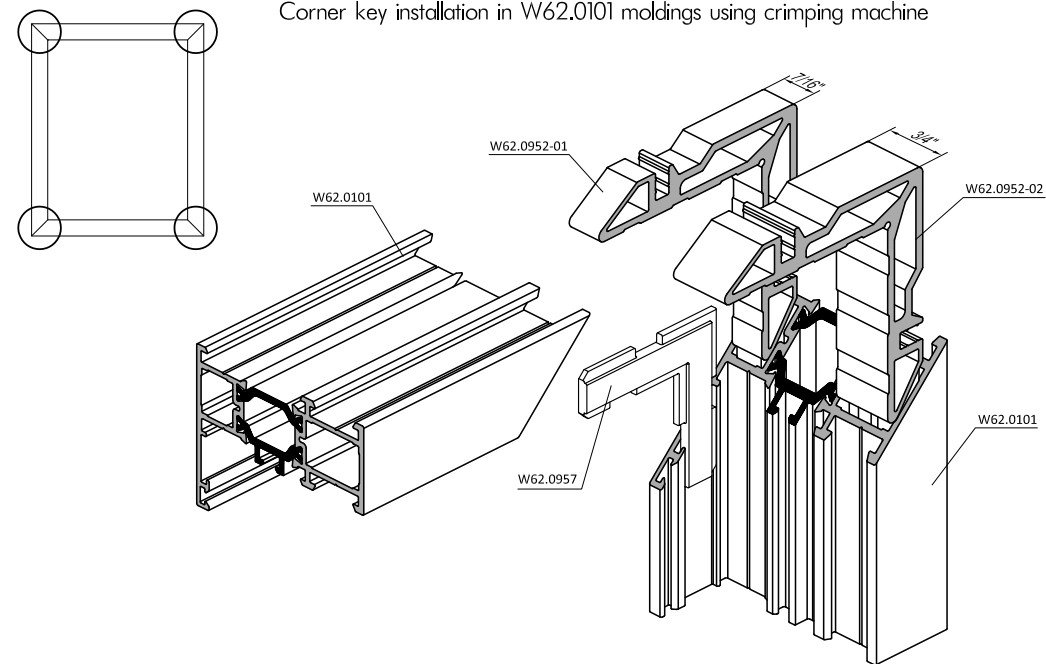

Corner key installation in W62.0101 moldings using pins

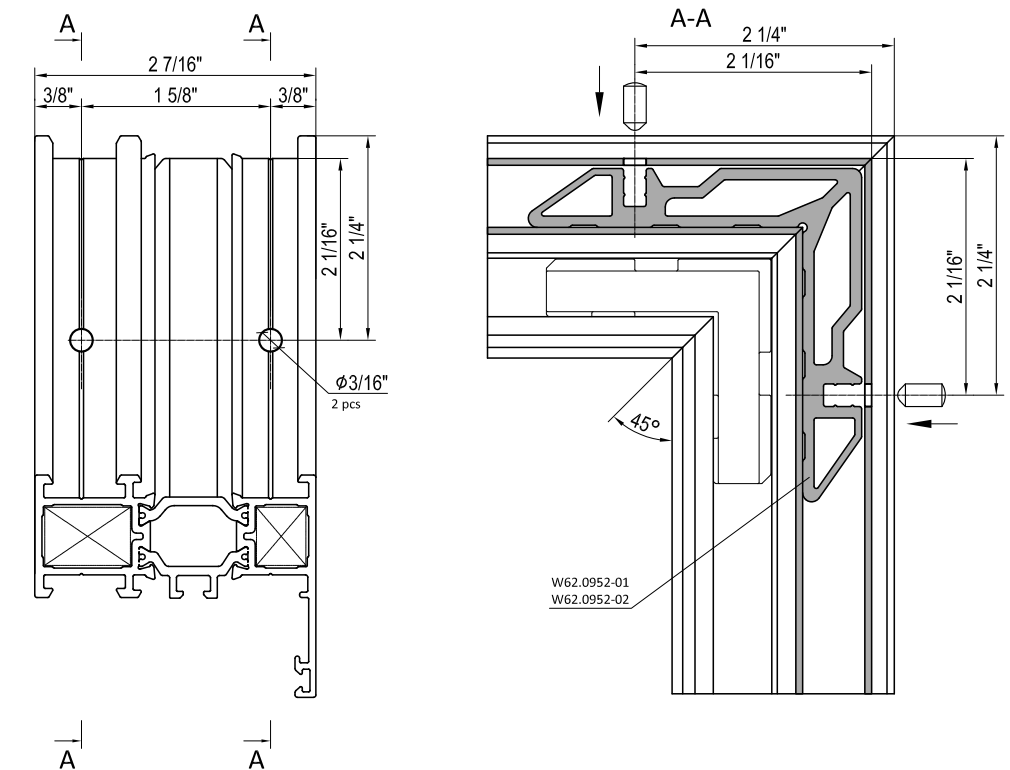
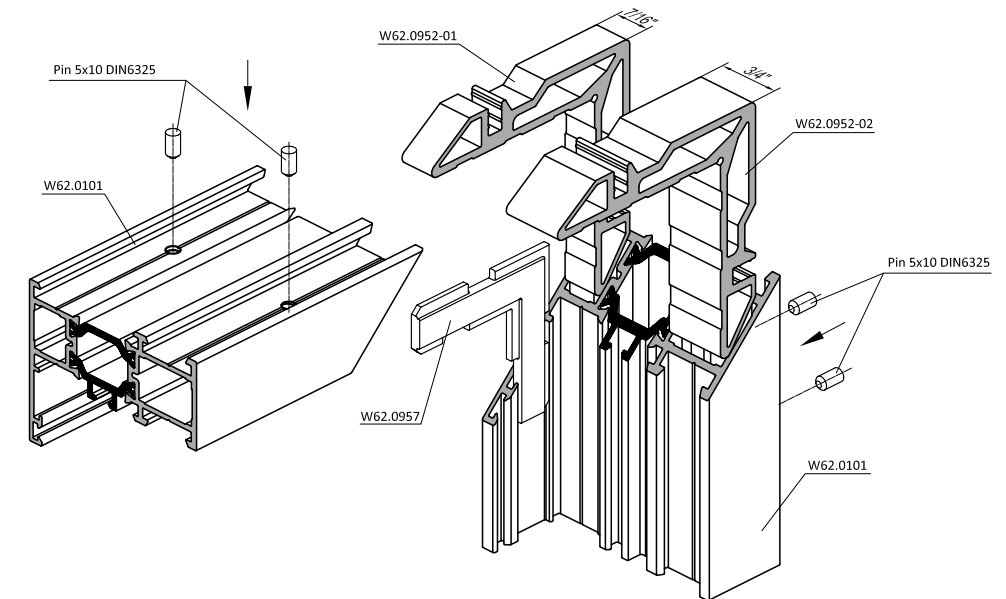

Apply Weiss Cosmopur 819 on inside moldings' surface

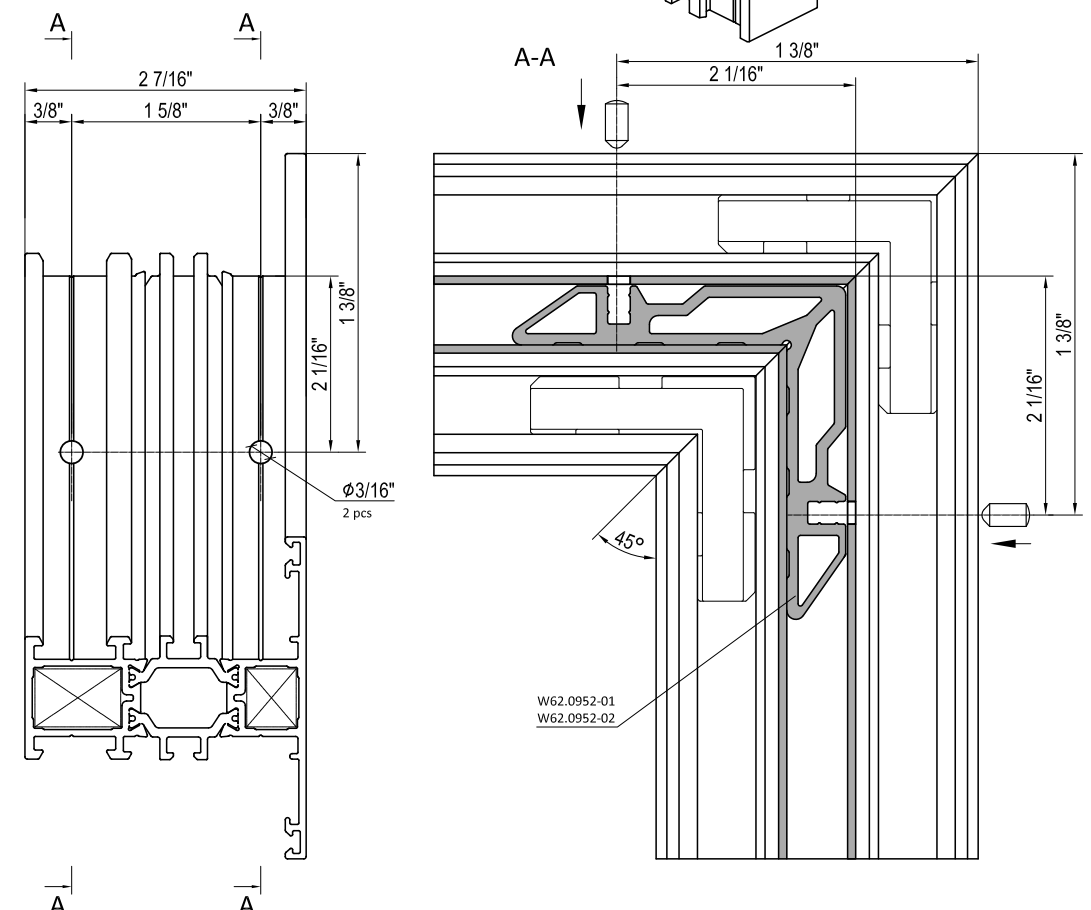
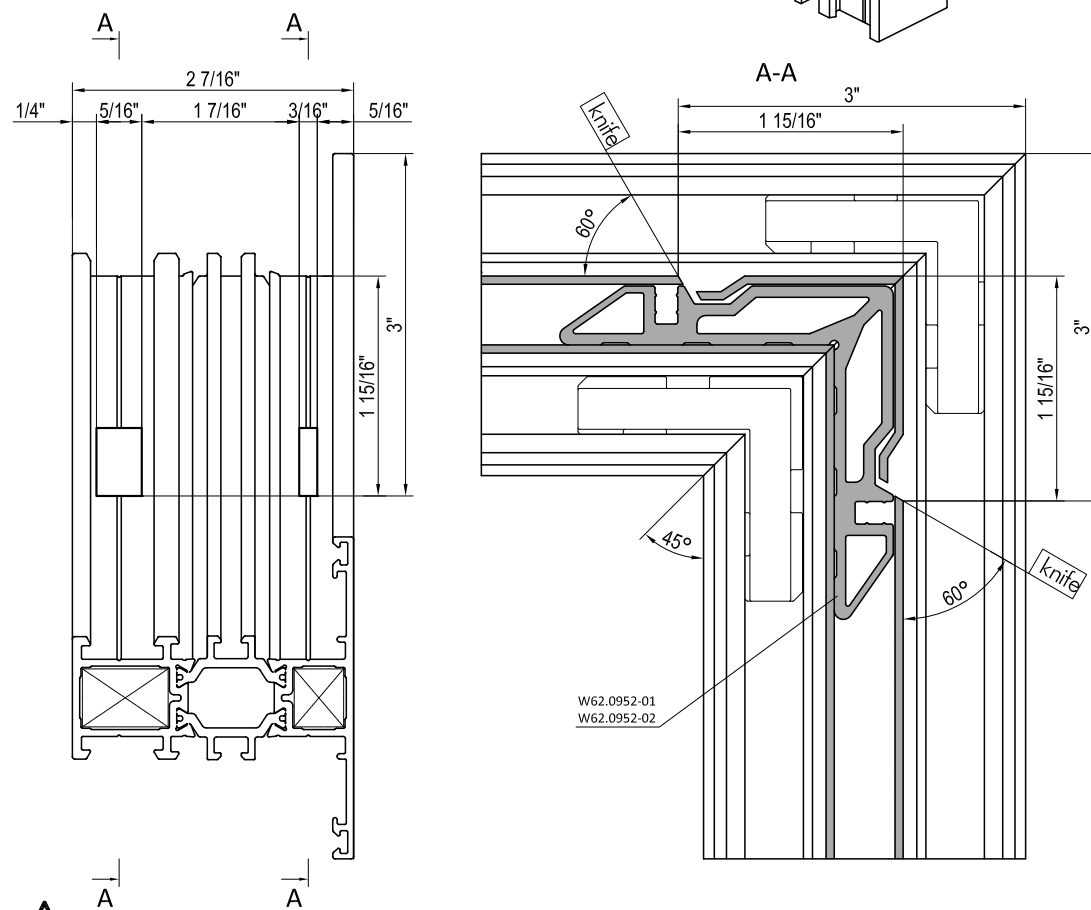
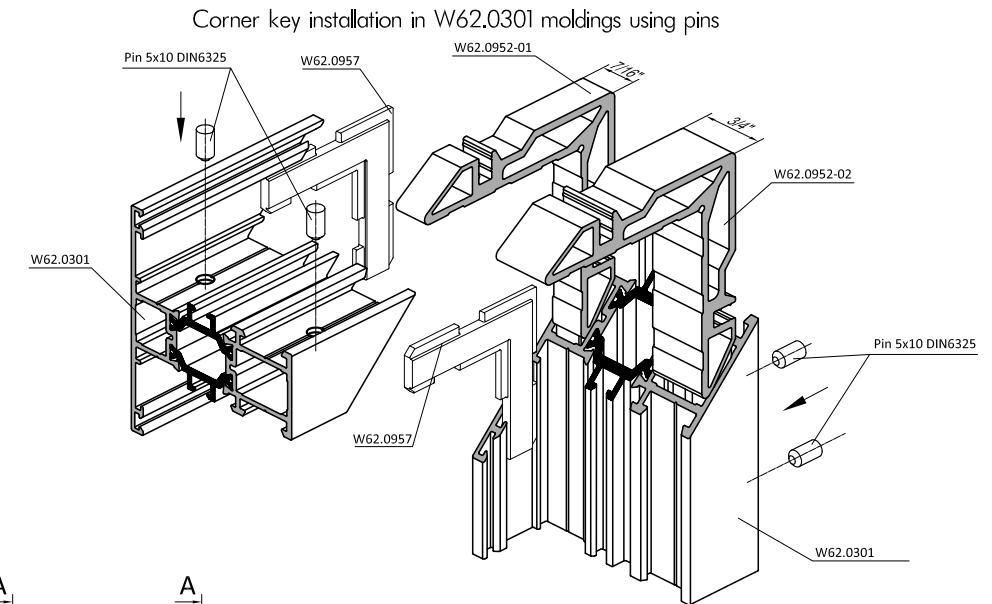
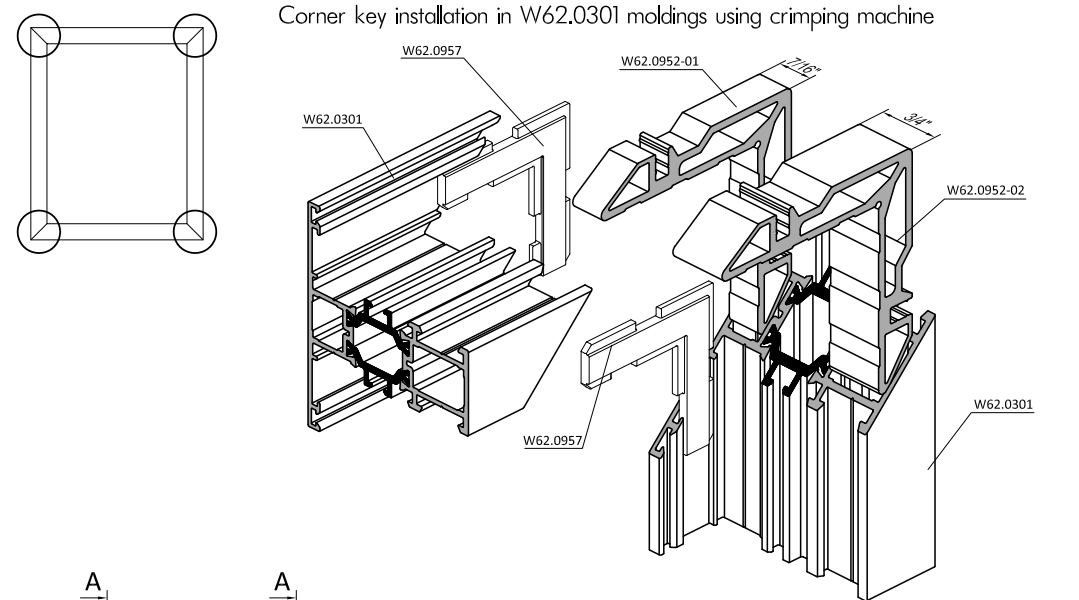

⚠ Apply Weiss Cosmopur 819 on inside moldings' surface

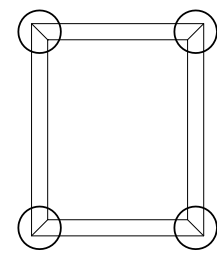

Corner key installation in W62.0102 moldings using crimping machine

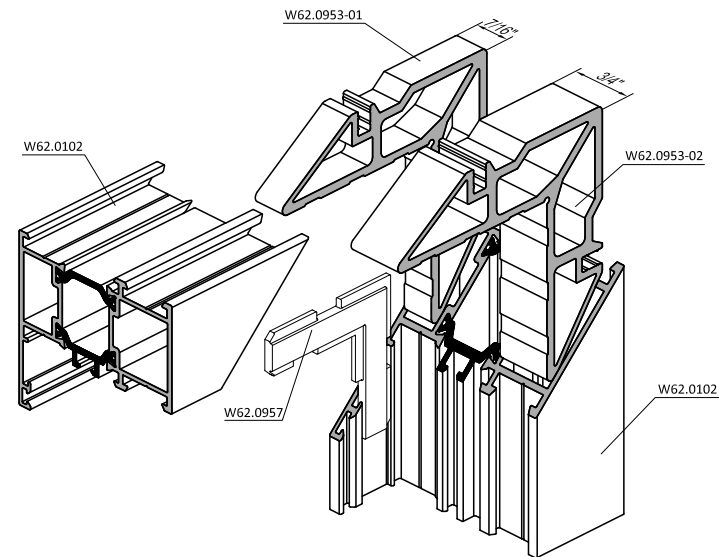

Corner key installation in W62.0102 moldings using pins

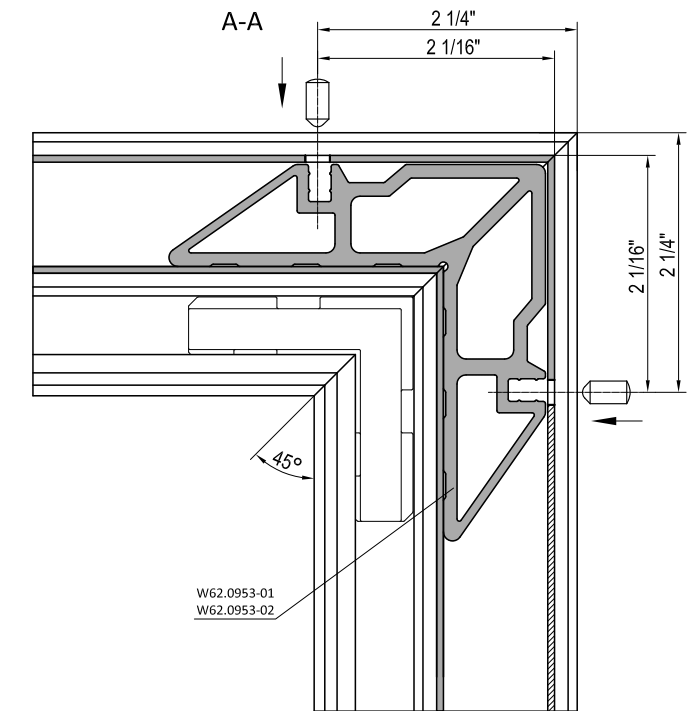
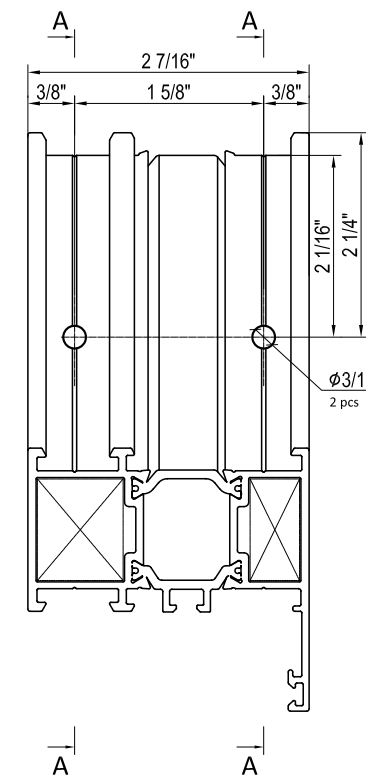
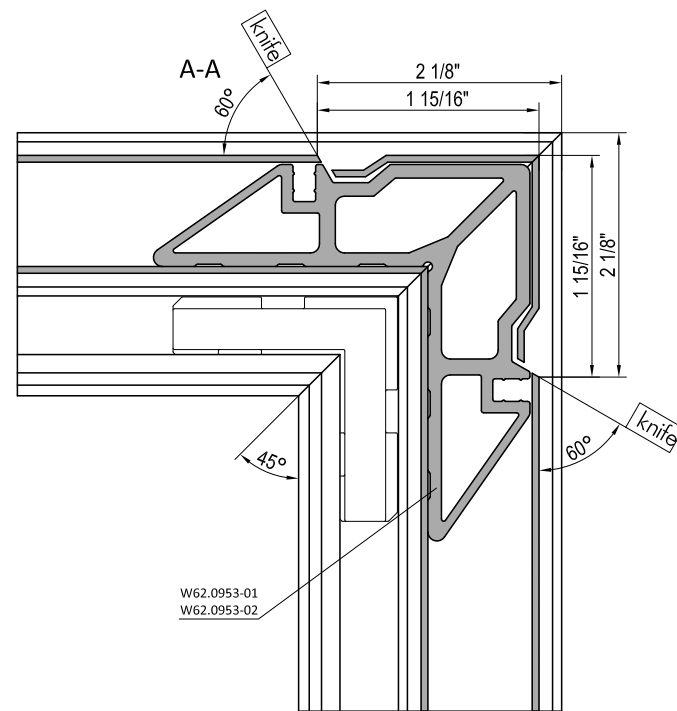
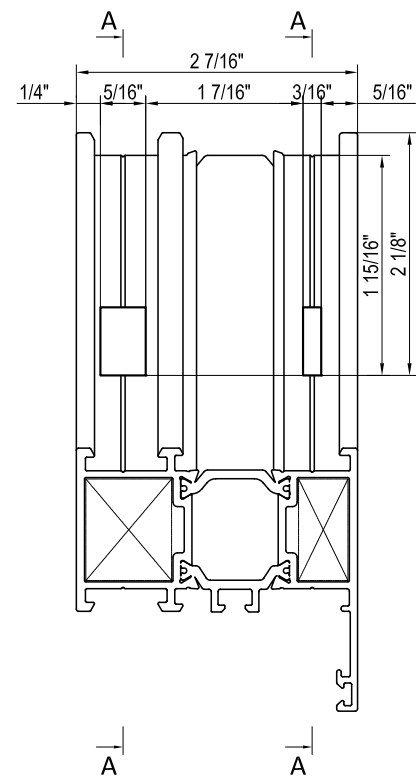
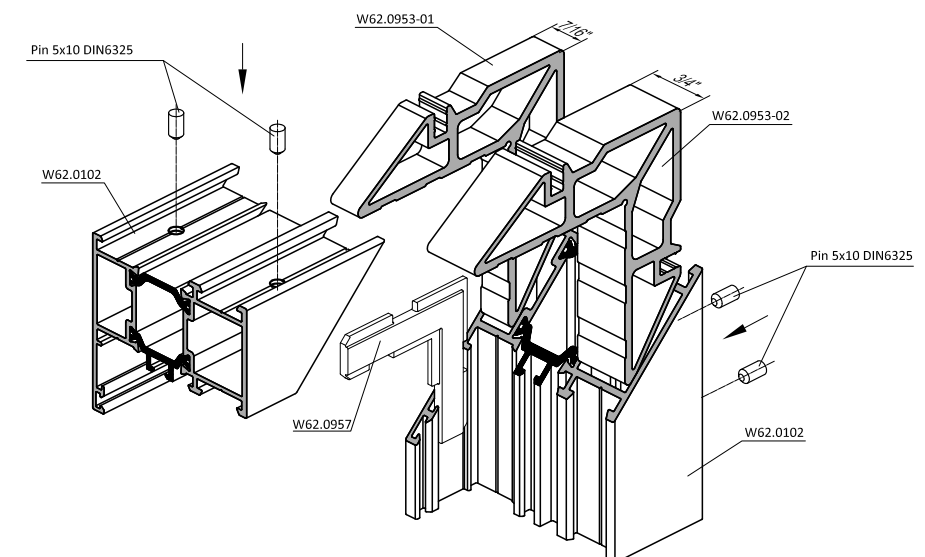

Apply Weiss Cosmopur 819 on inside moldings' surface

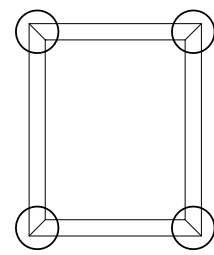

Corner key installation in W62.0302 moldings using crimping machine

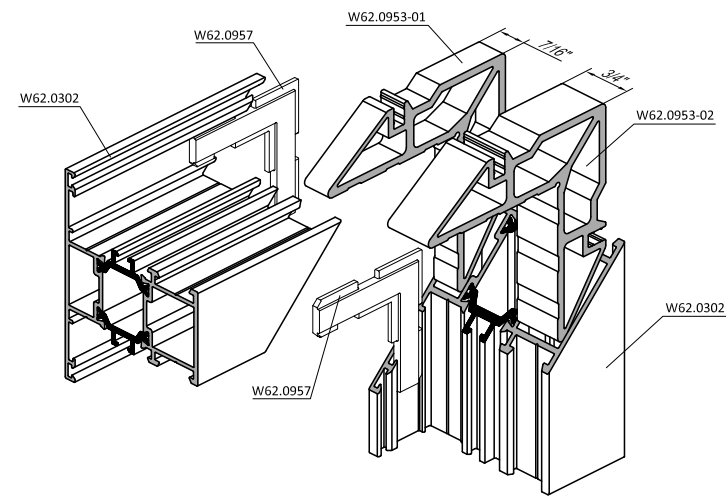

Corner key installation in W62.0302 moldings using pins

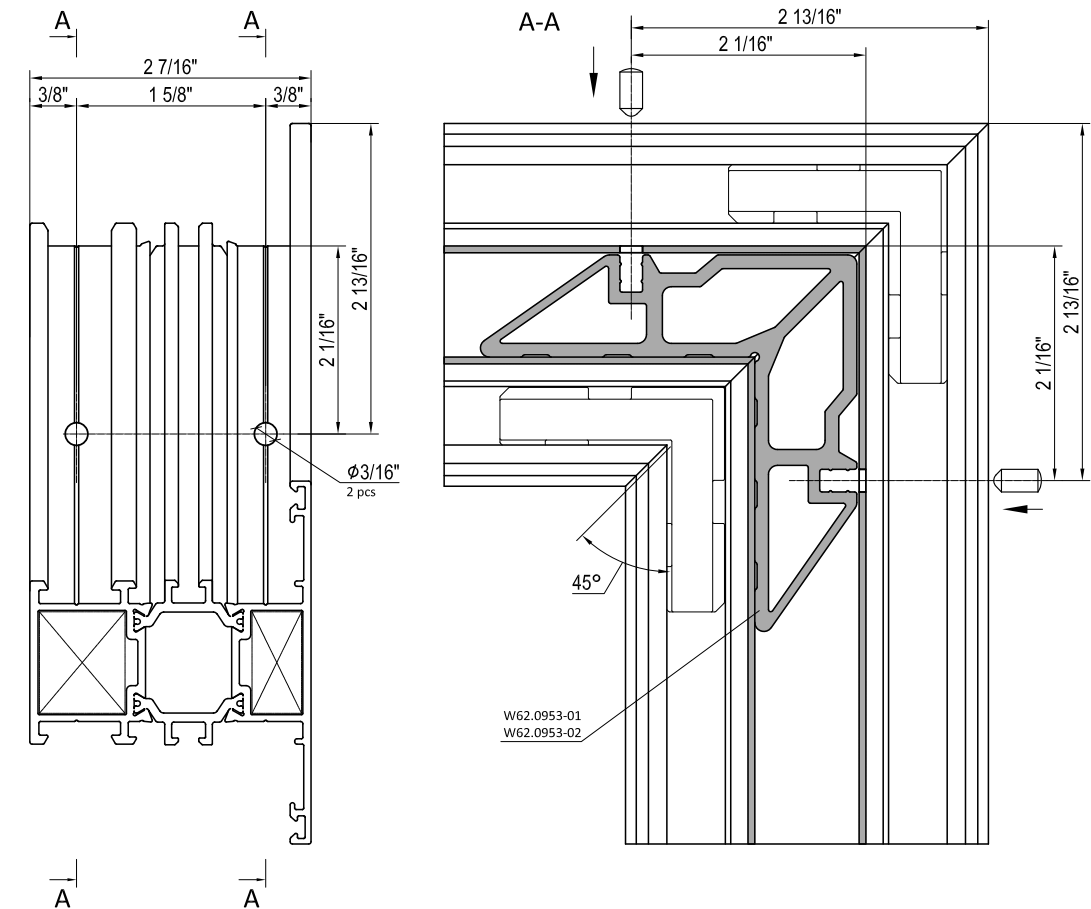
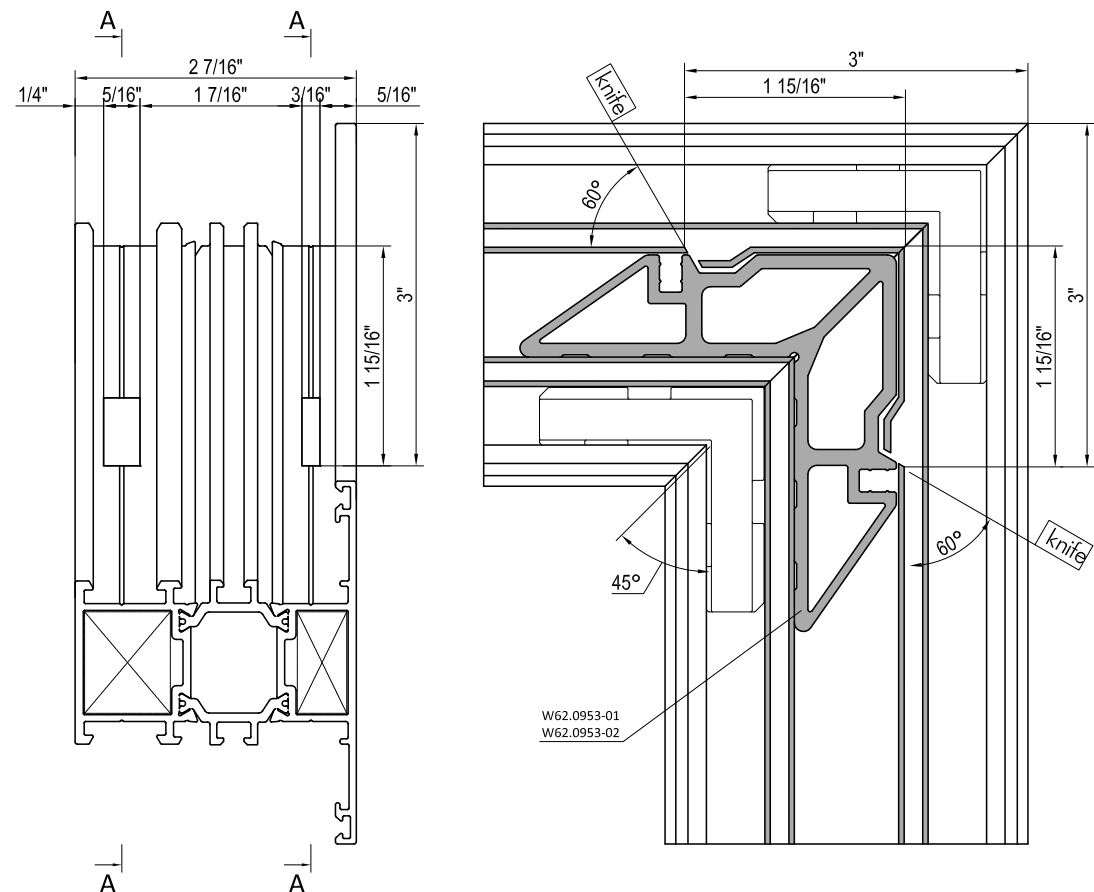
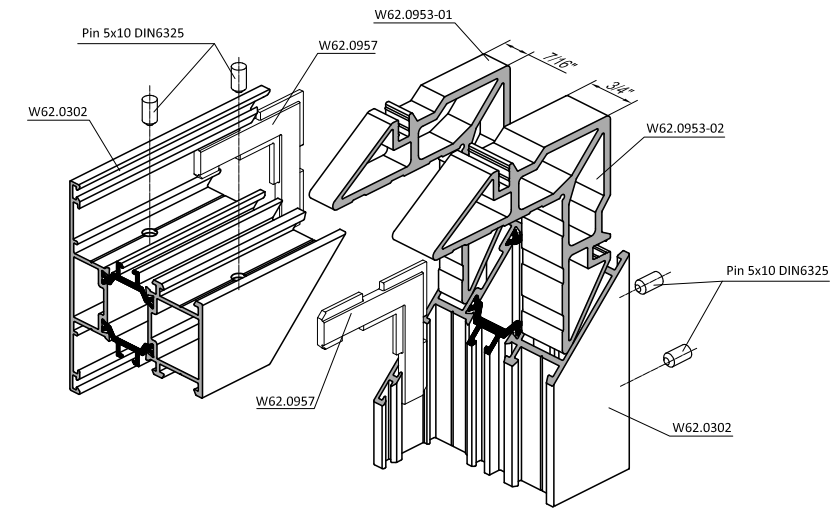

Apply Weiss Cosmopur 819 on inside moldings' surface

Corner key installation in W62.0103 moldings using crimping machine

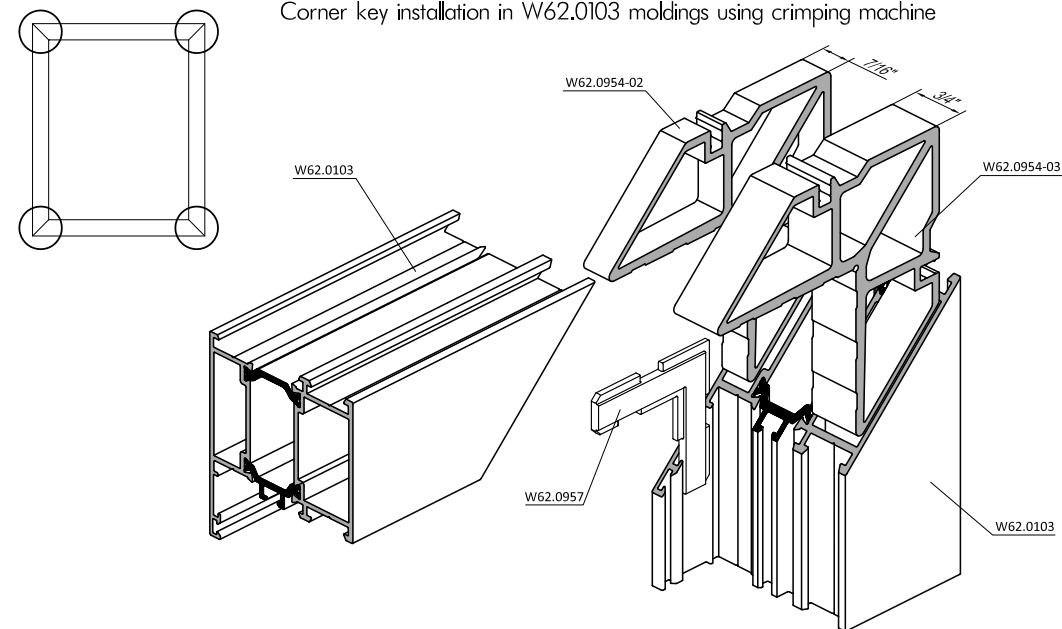

Corner key installation in W62.0103 moldings using pins

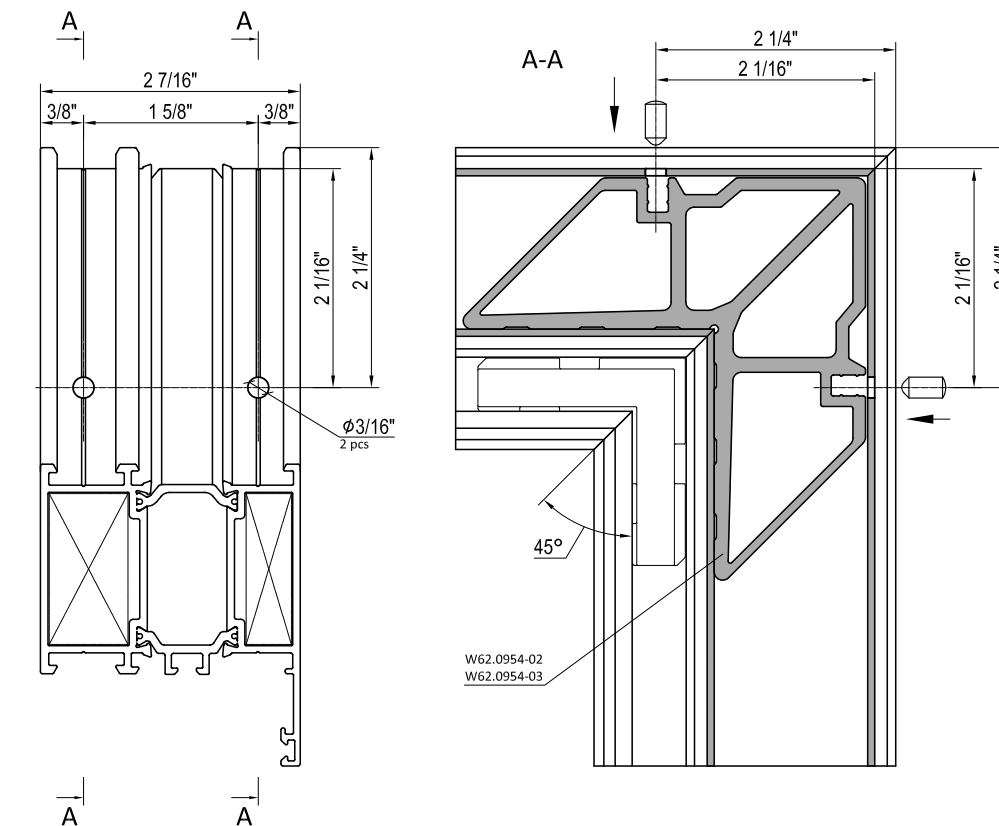
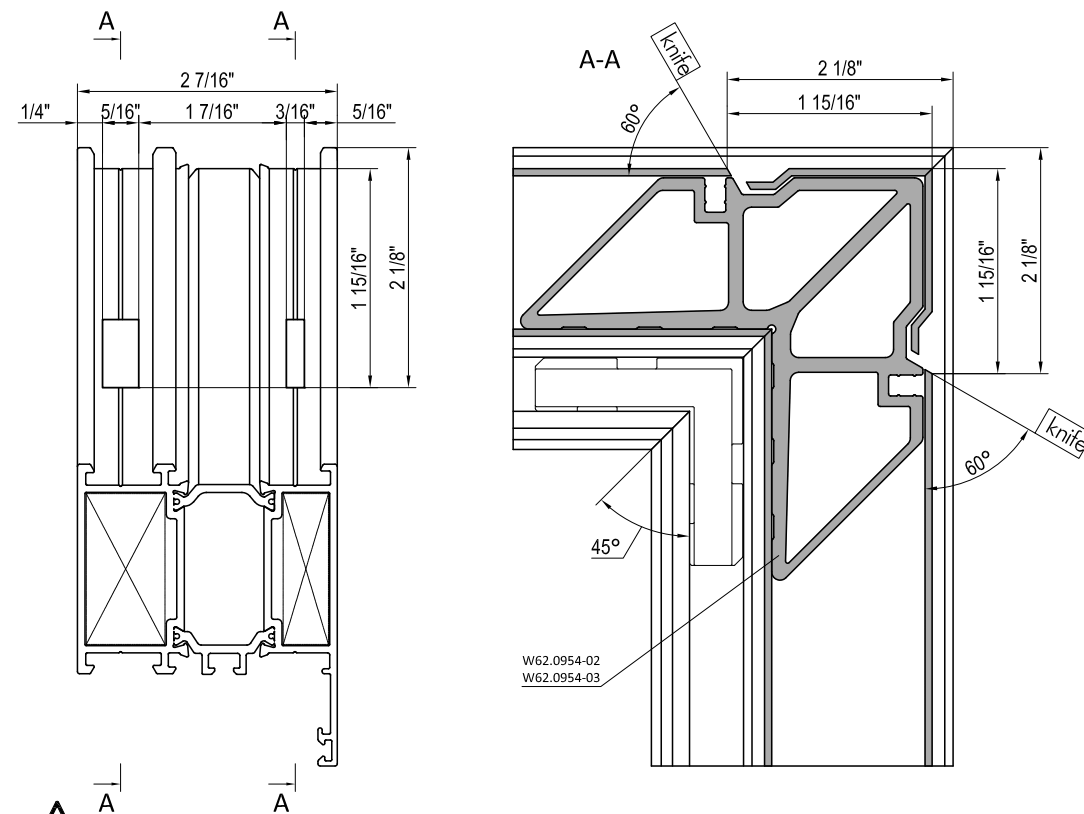
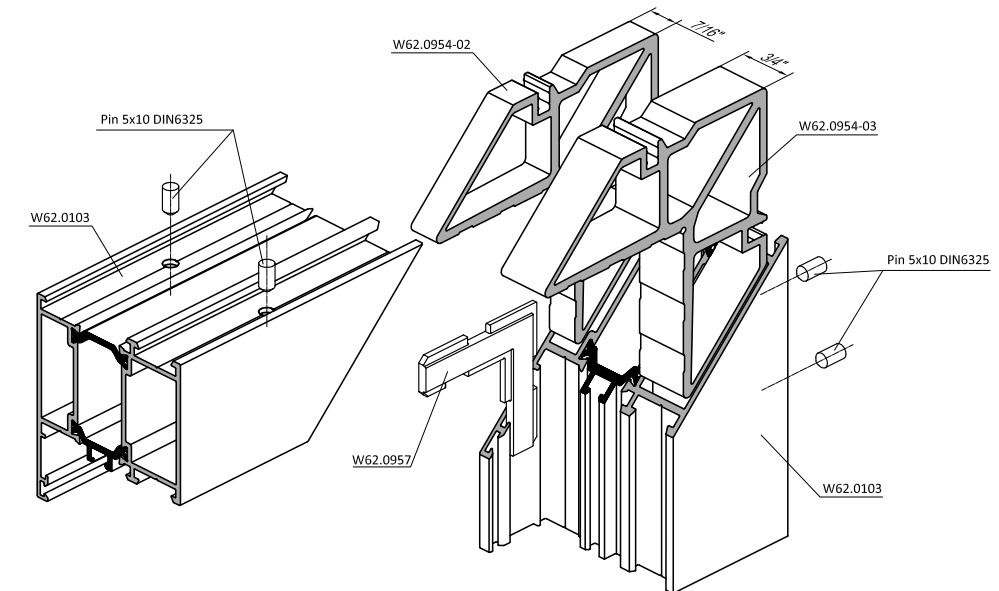

⚠ Apply Weiss Cosmopur 819 on inside moldings' surface

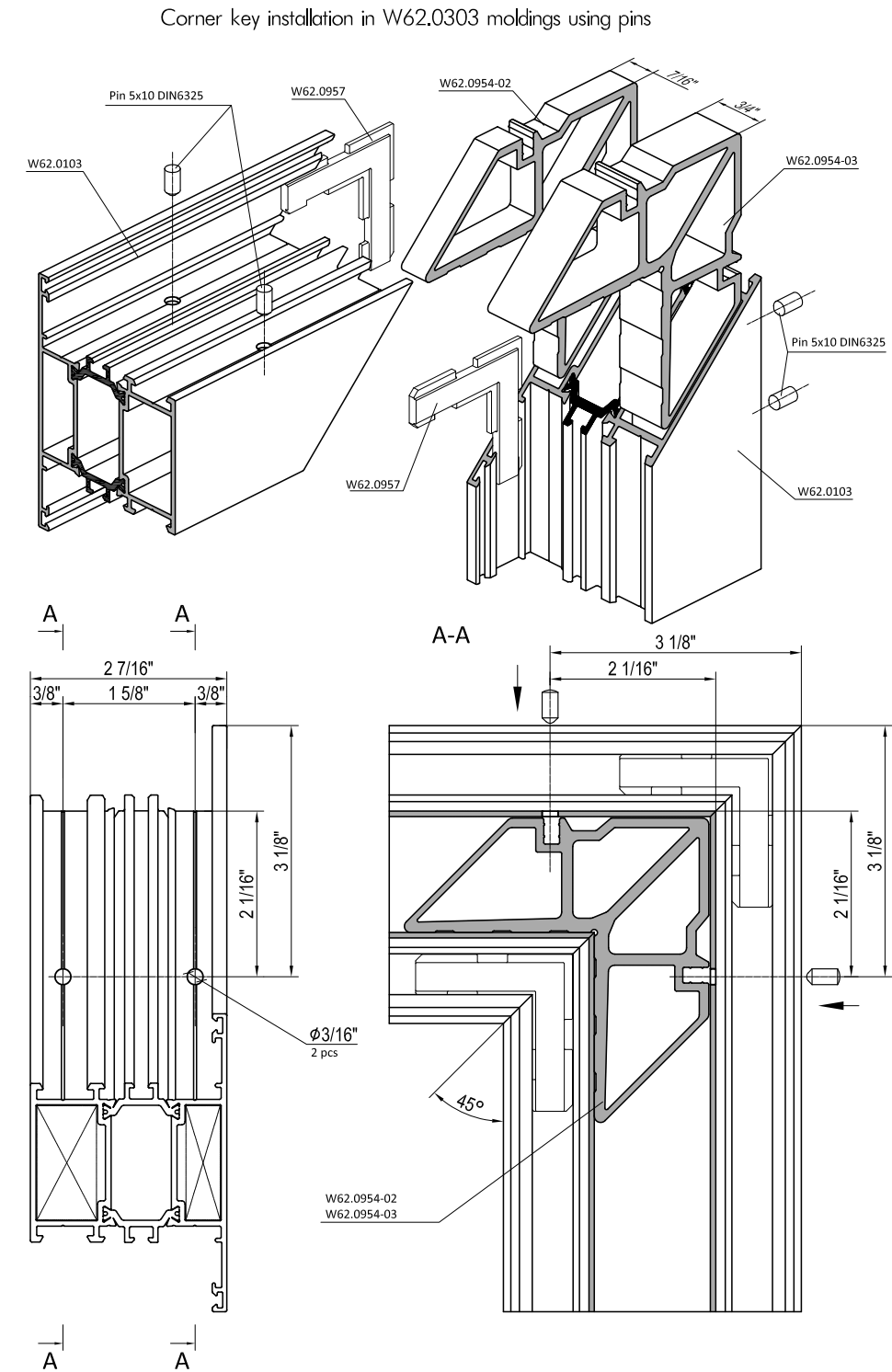
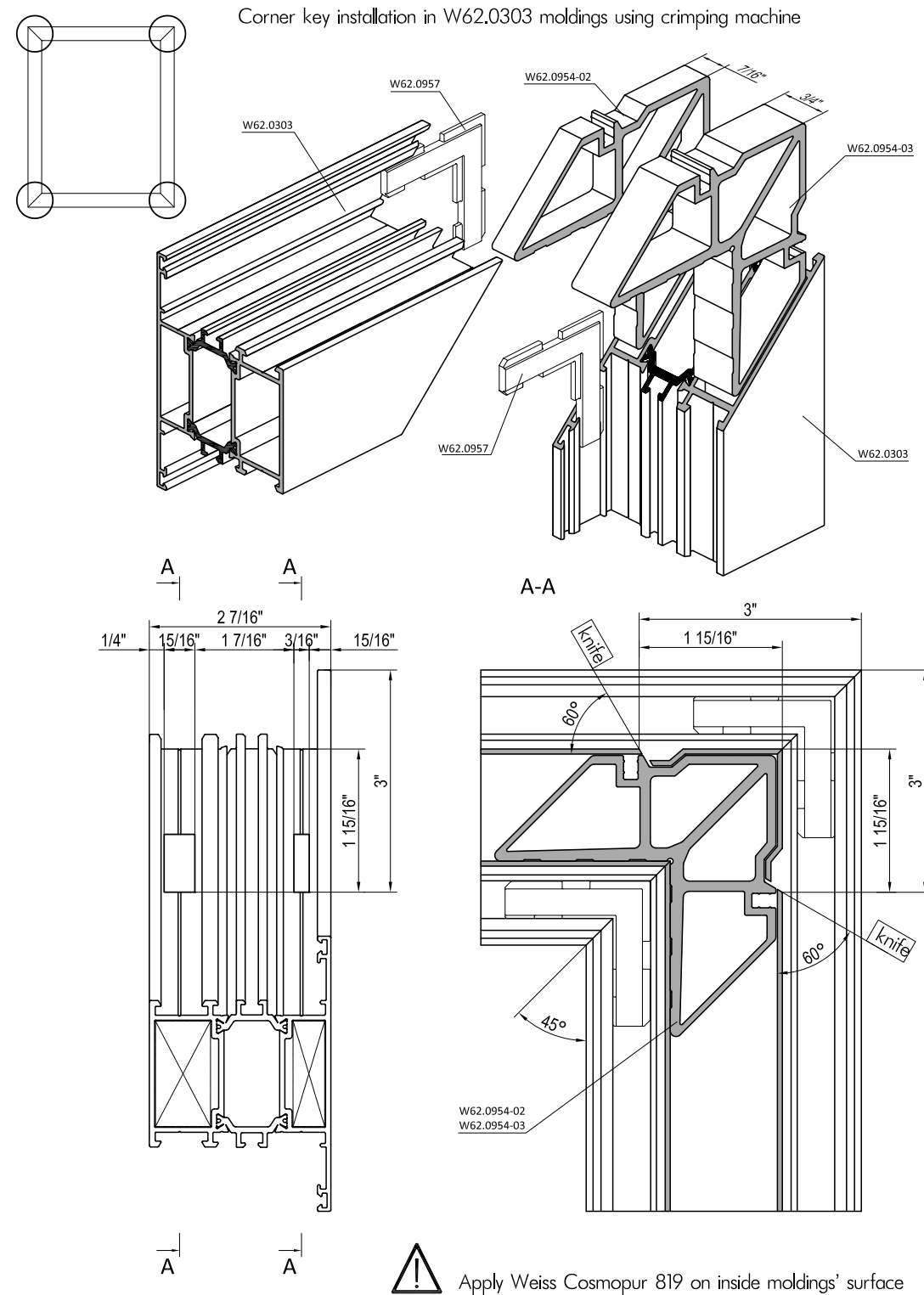

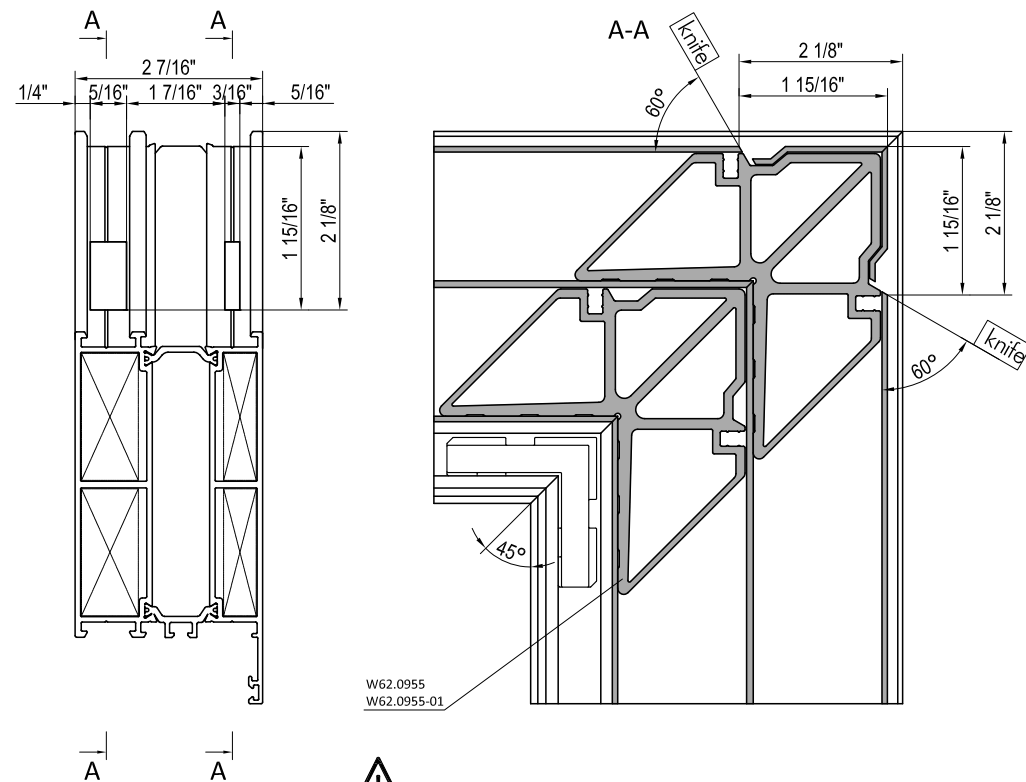
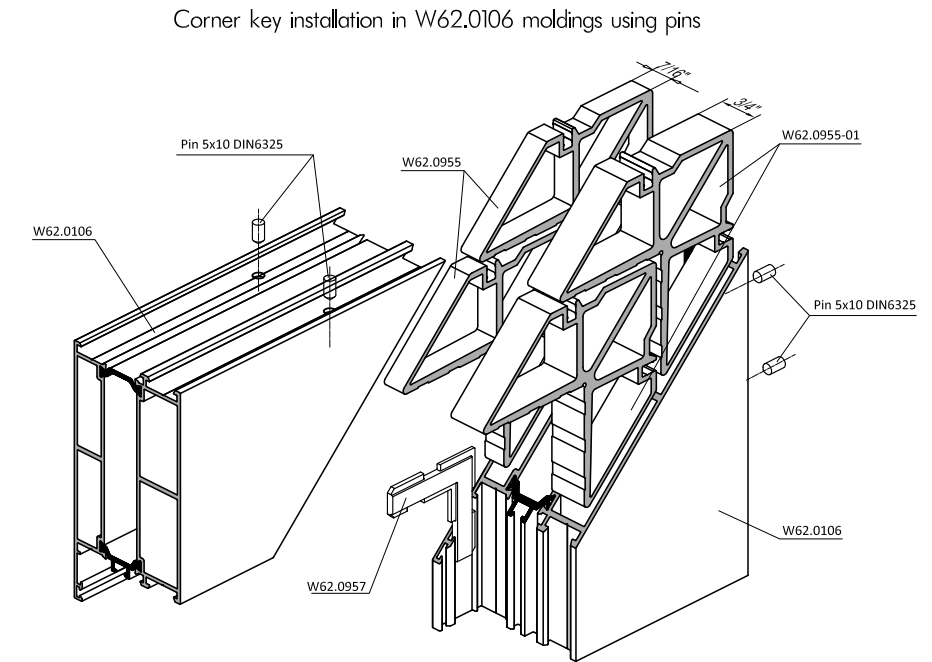
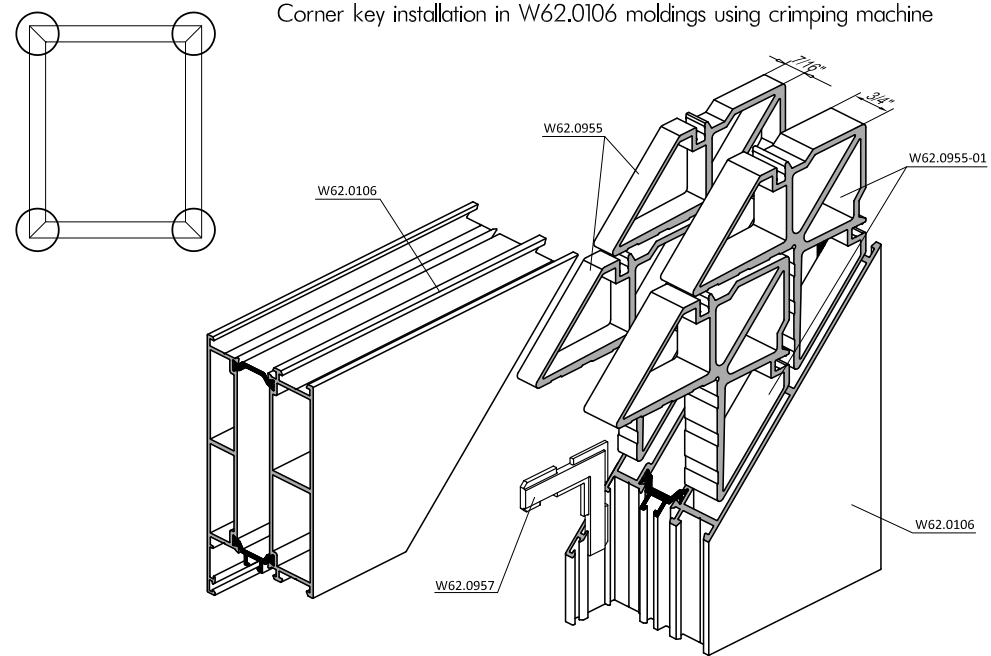

⚠ Apply Weiss Cosmopur 819 on inside moldings' surface

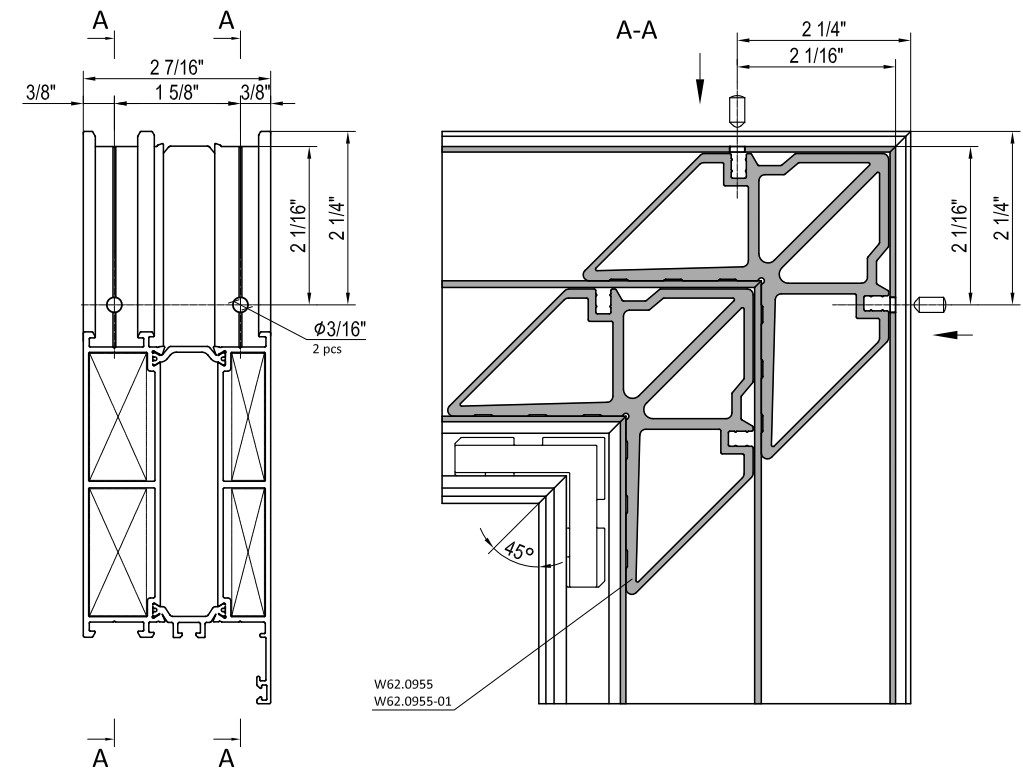

Corner key installation in W62.0201 moldings using crimping machine

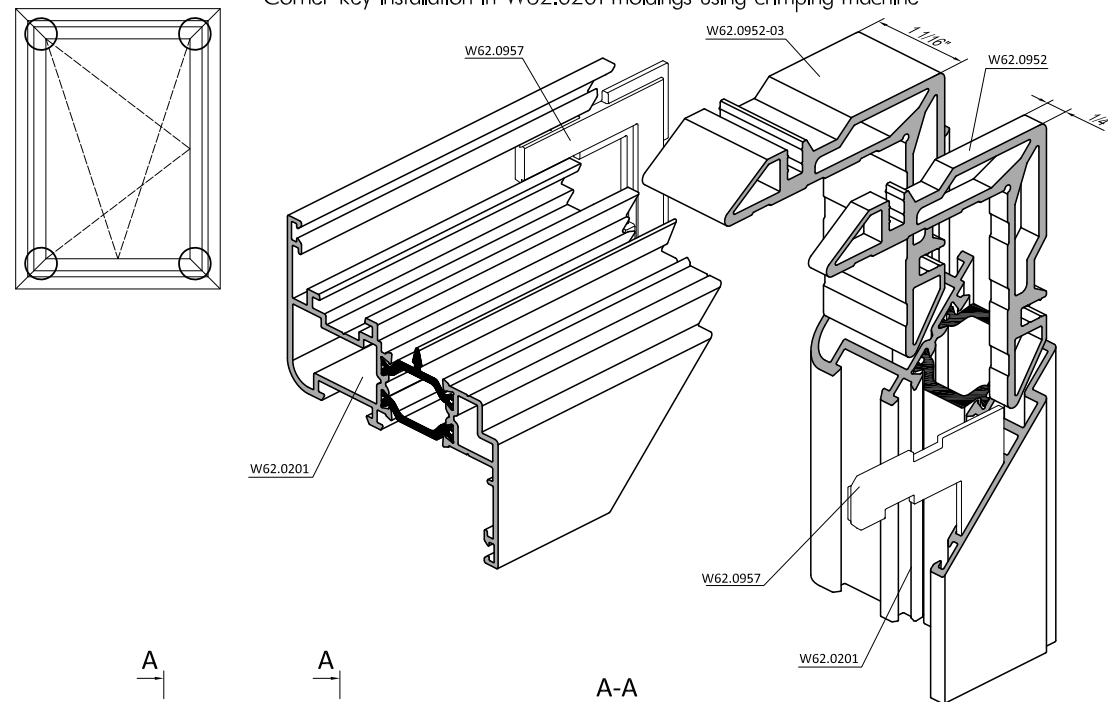

Corner key installation in W62.0201 moldings using pins

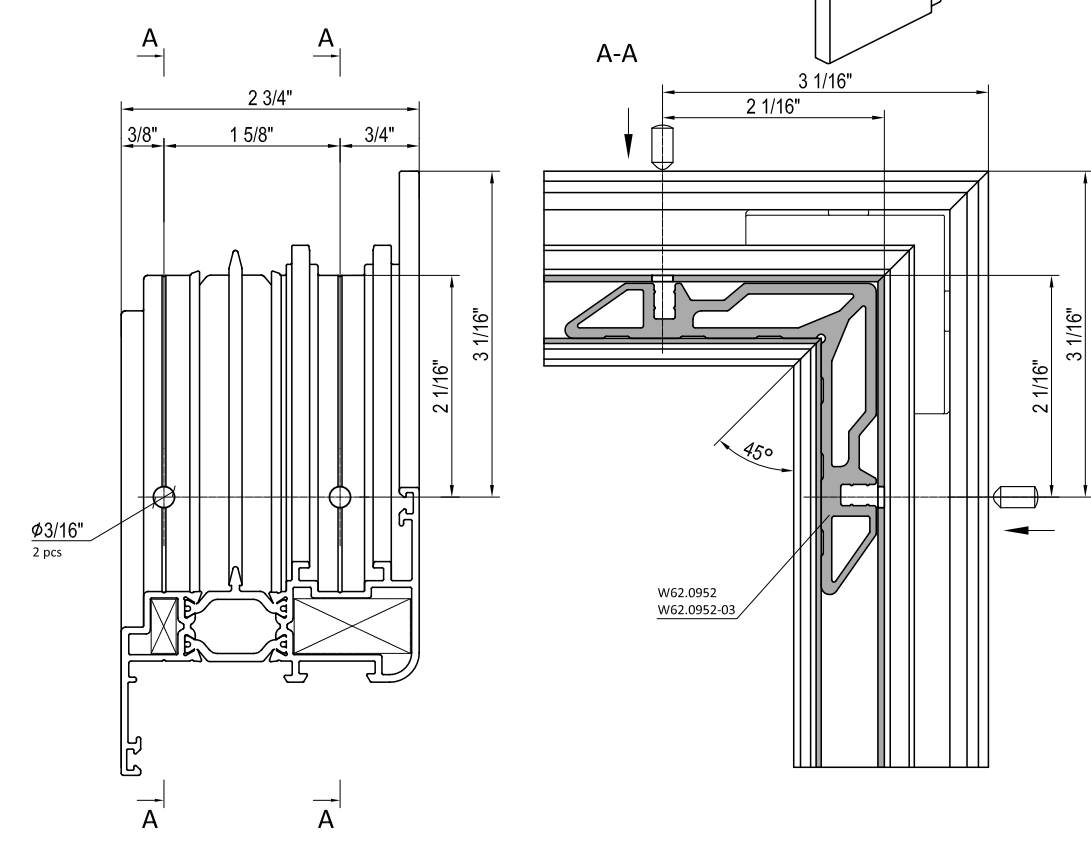
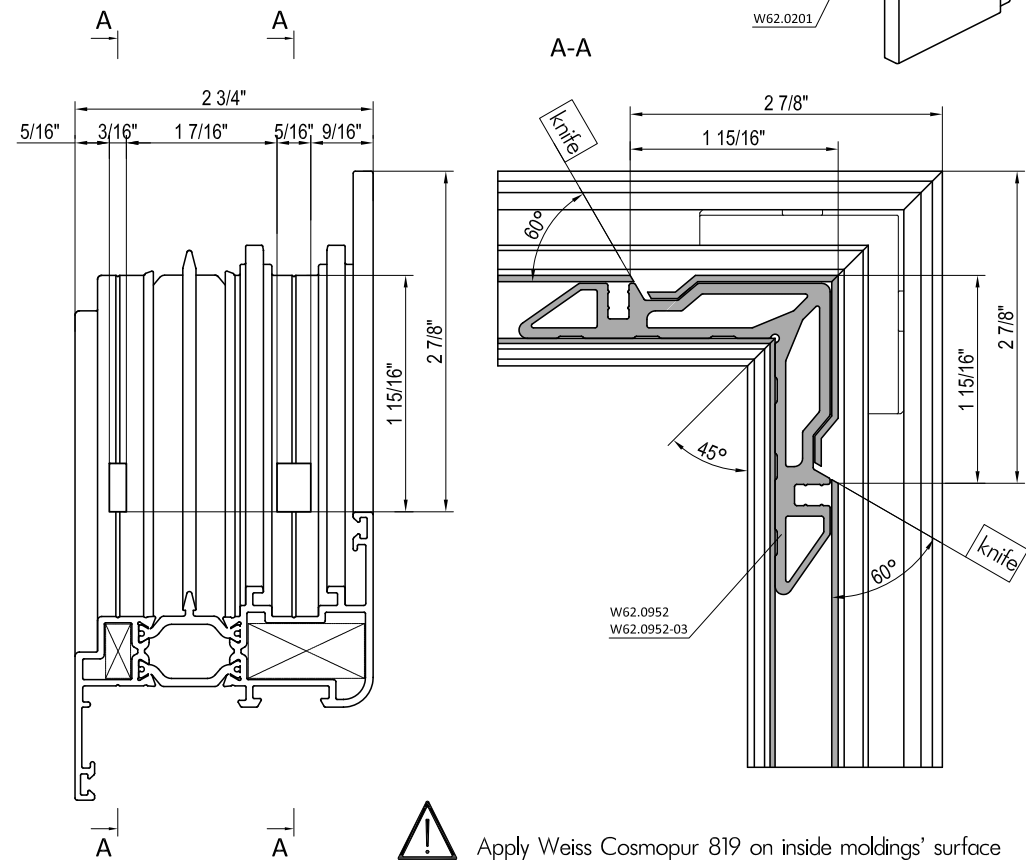
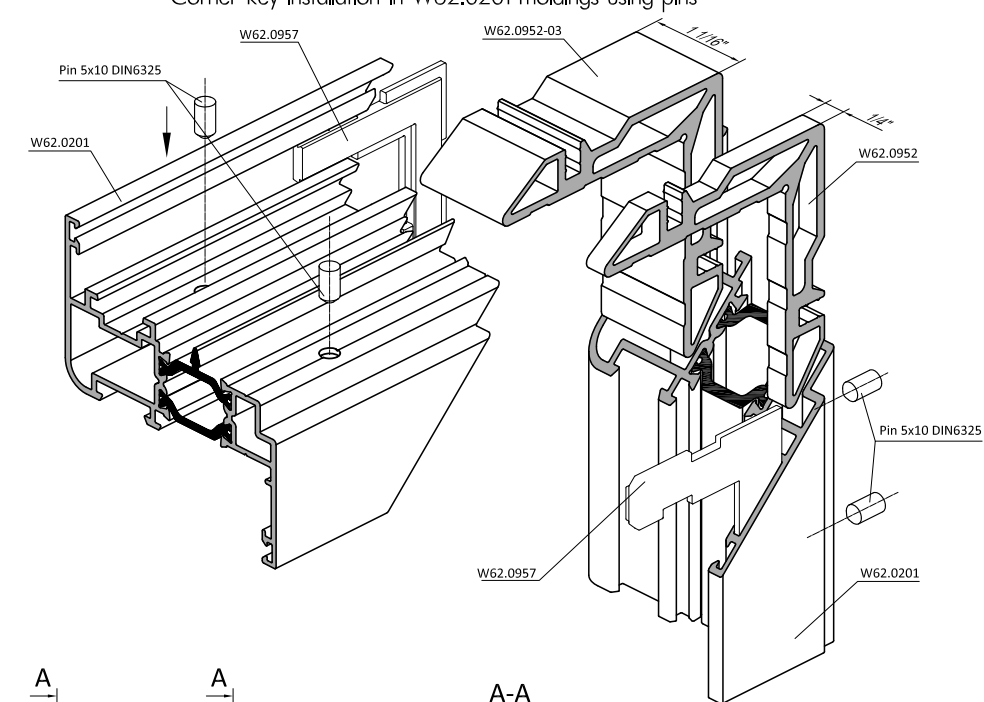

Corner key installation in W62.0202 moldings using crimping machine

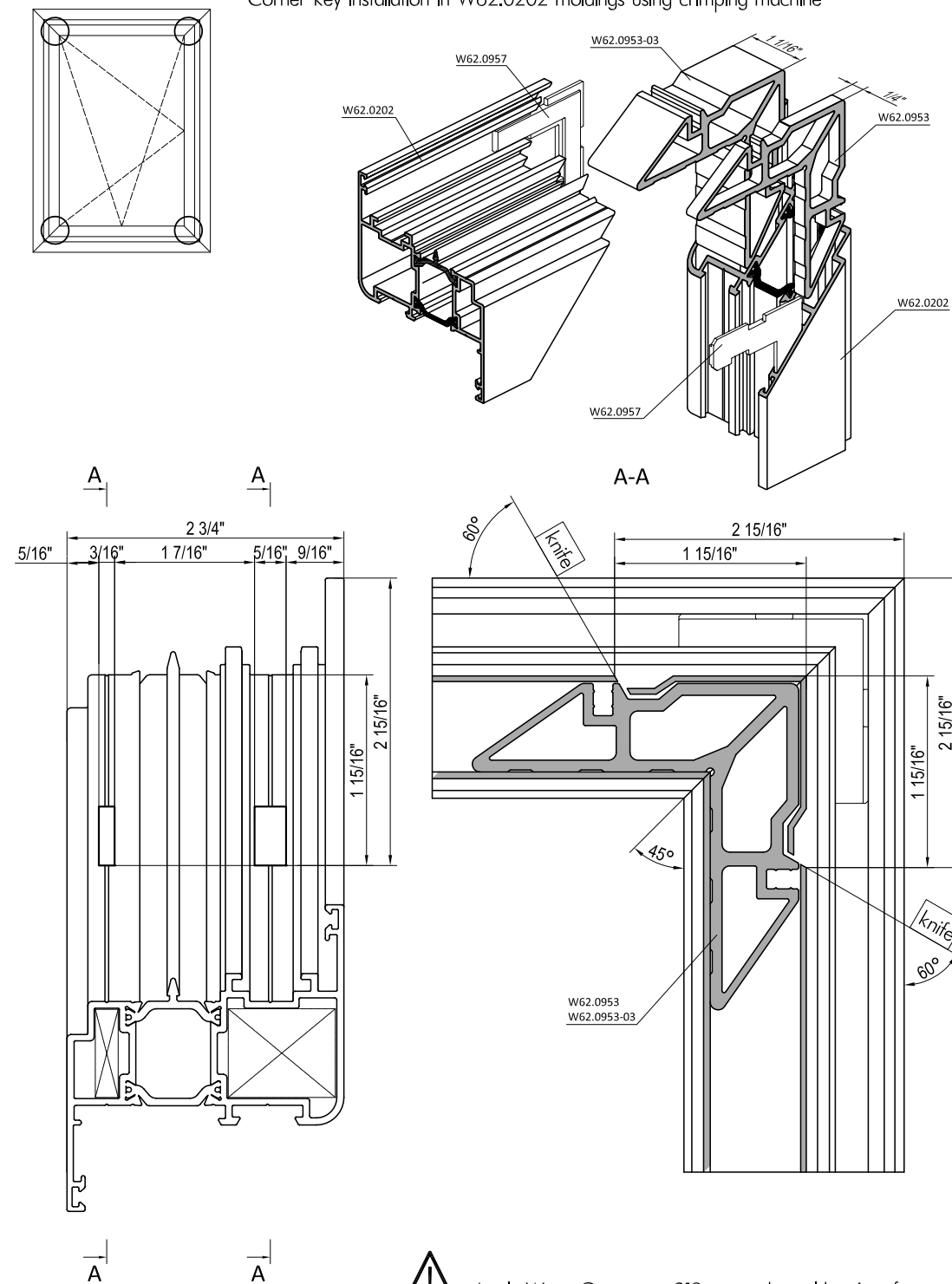

Corner key installation in W62.0202 moldings using pins

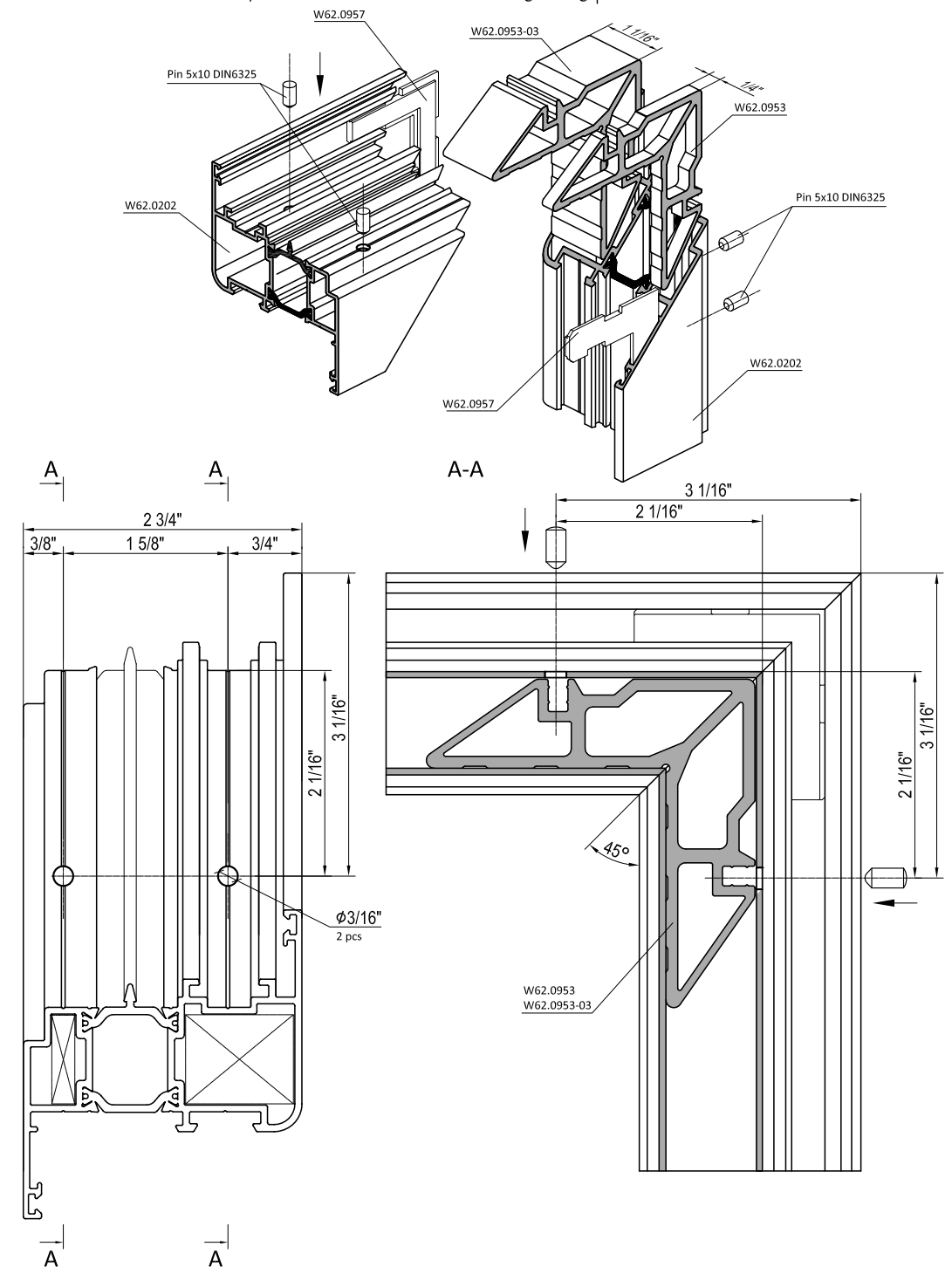

Corner key installation in W62.0203 moldings using crimping machine

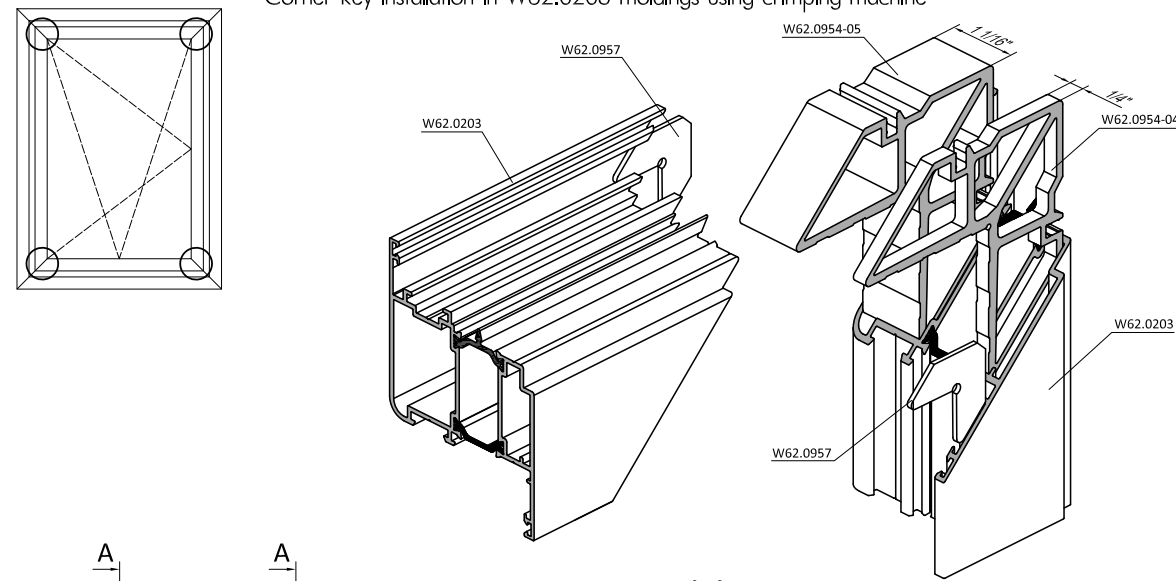

Corner key installation in W62.0203 moldings using pins

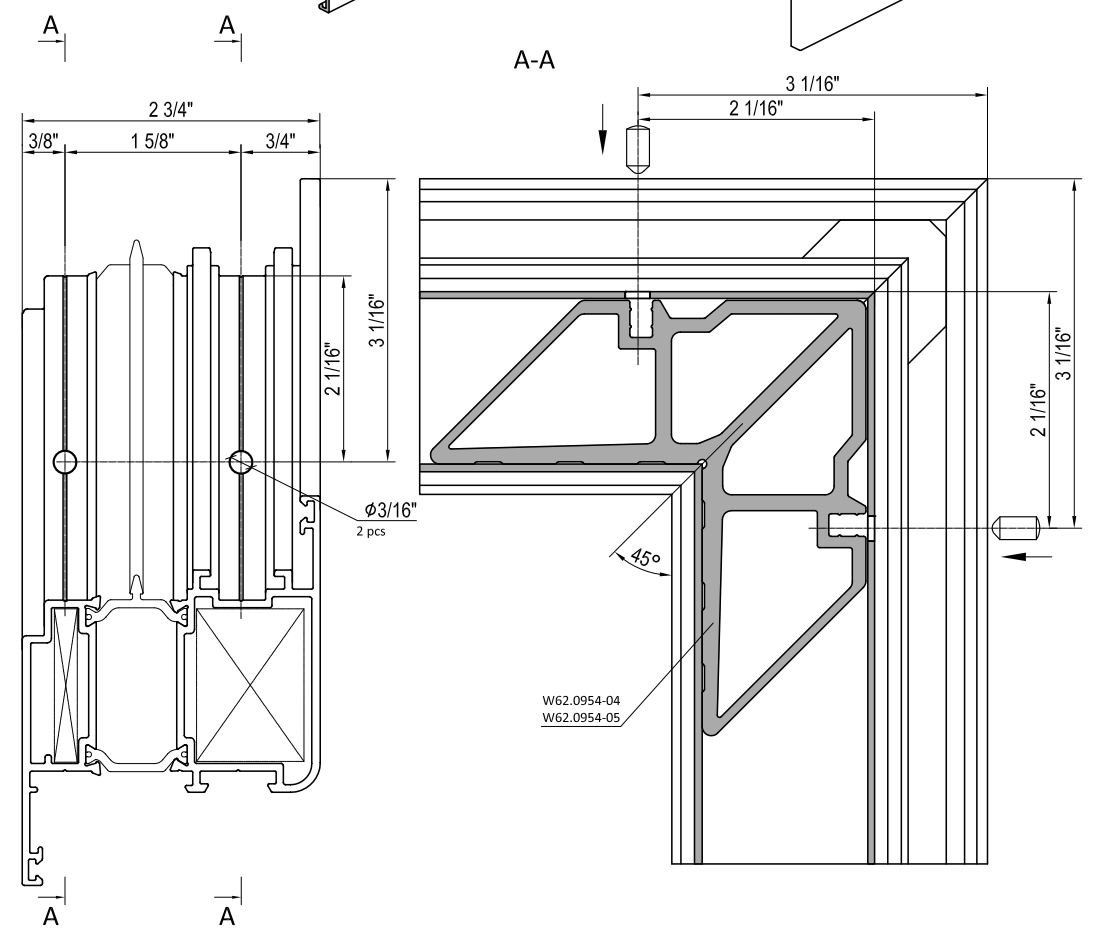
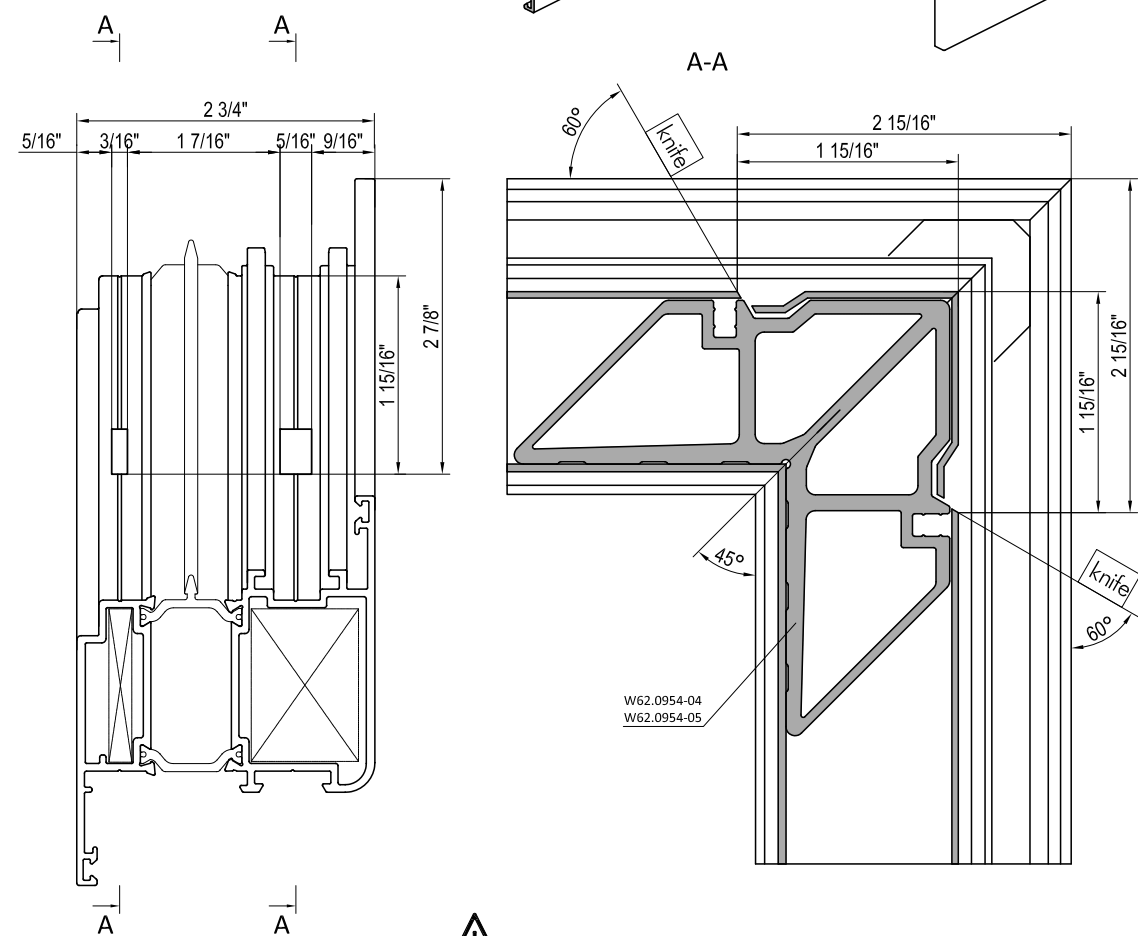
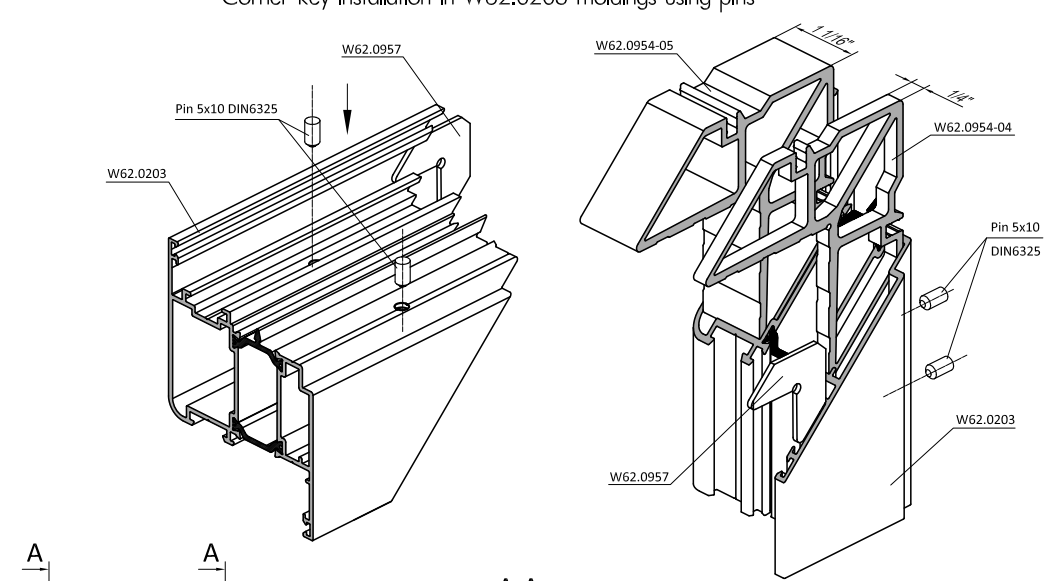

⚠ Apply Weiss Cosmopur 819 on inside moldings' surface

Corner key installation in W62.0104 moldings using crimping machine. Variant 1

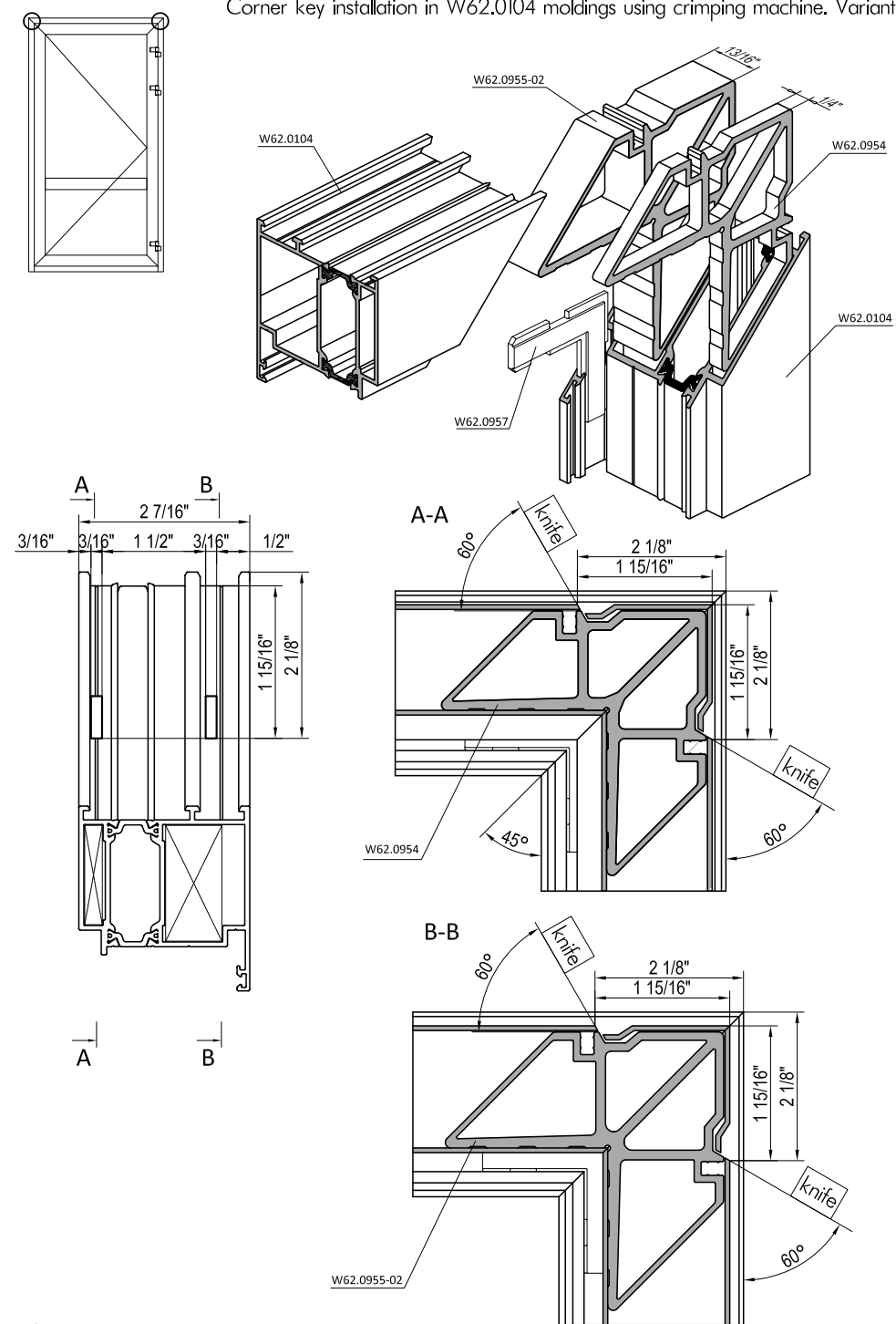

Corner key installation in W62.0104 moldings using crimping machine. Variant 2

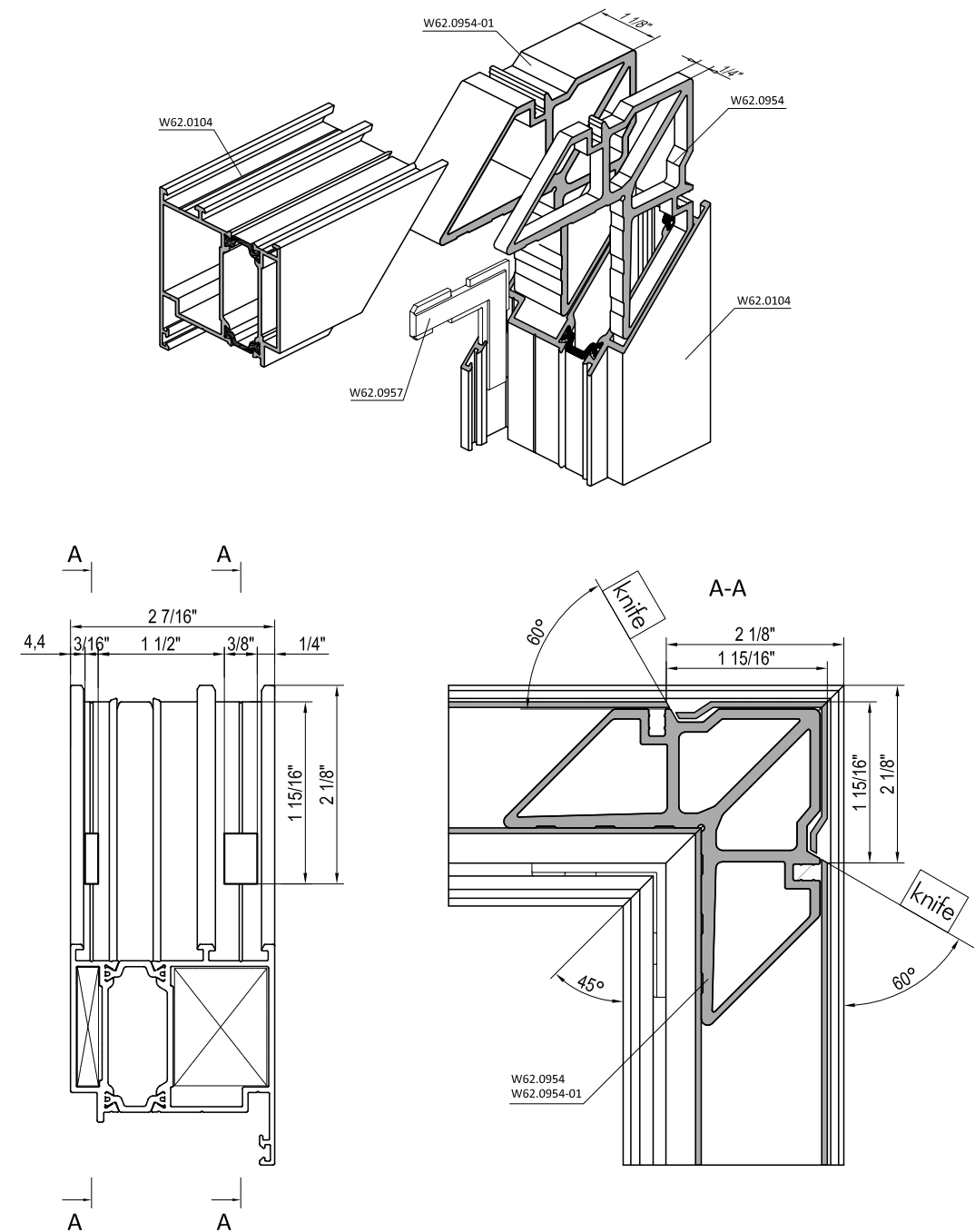

⚠ Apply Weiss Cosmopur 819 on inside moldings' surface

Corner key installation in W62.0104 moldings using pins. Variant 2

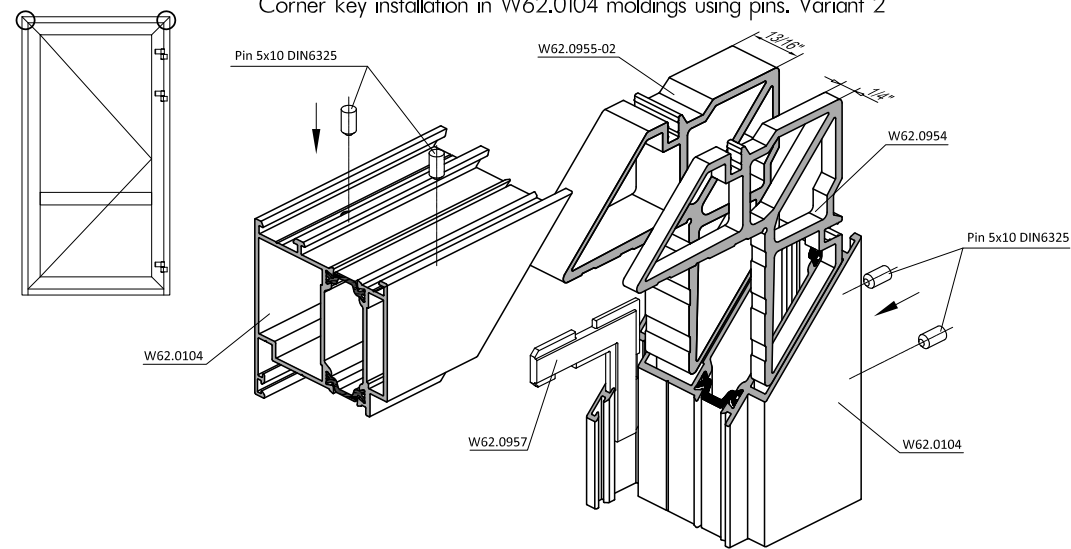

Corner key installation in W62.0104 moldings using pins. Variant 2

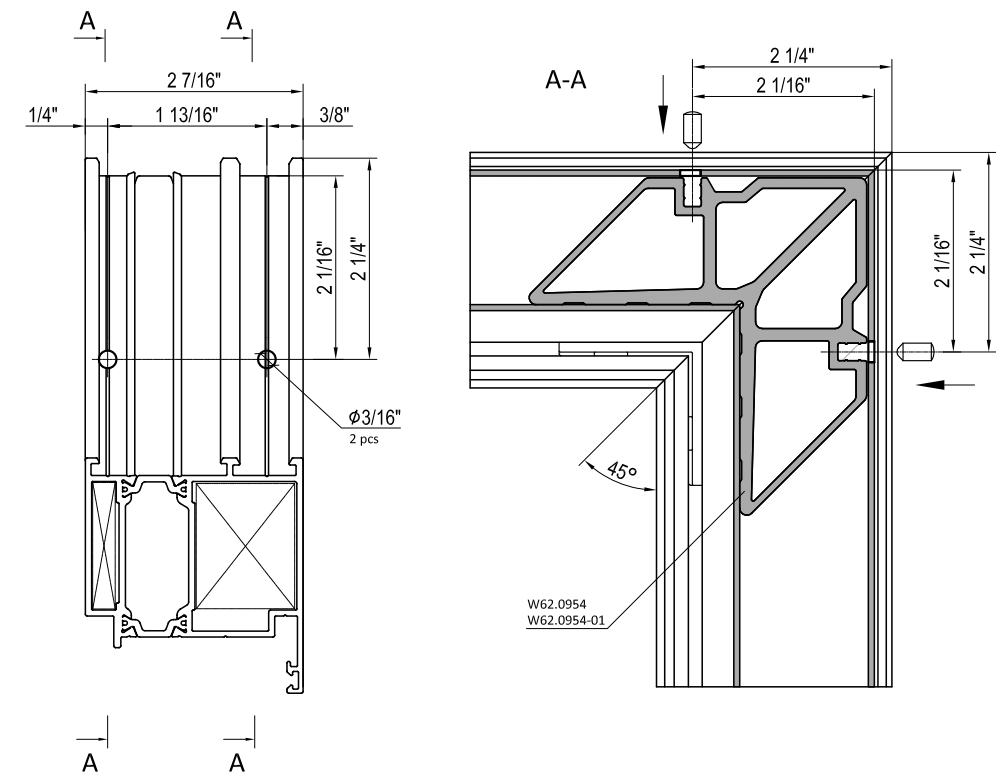
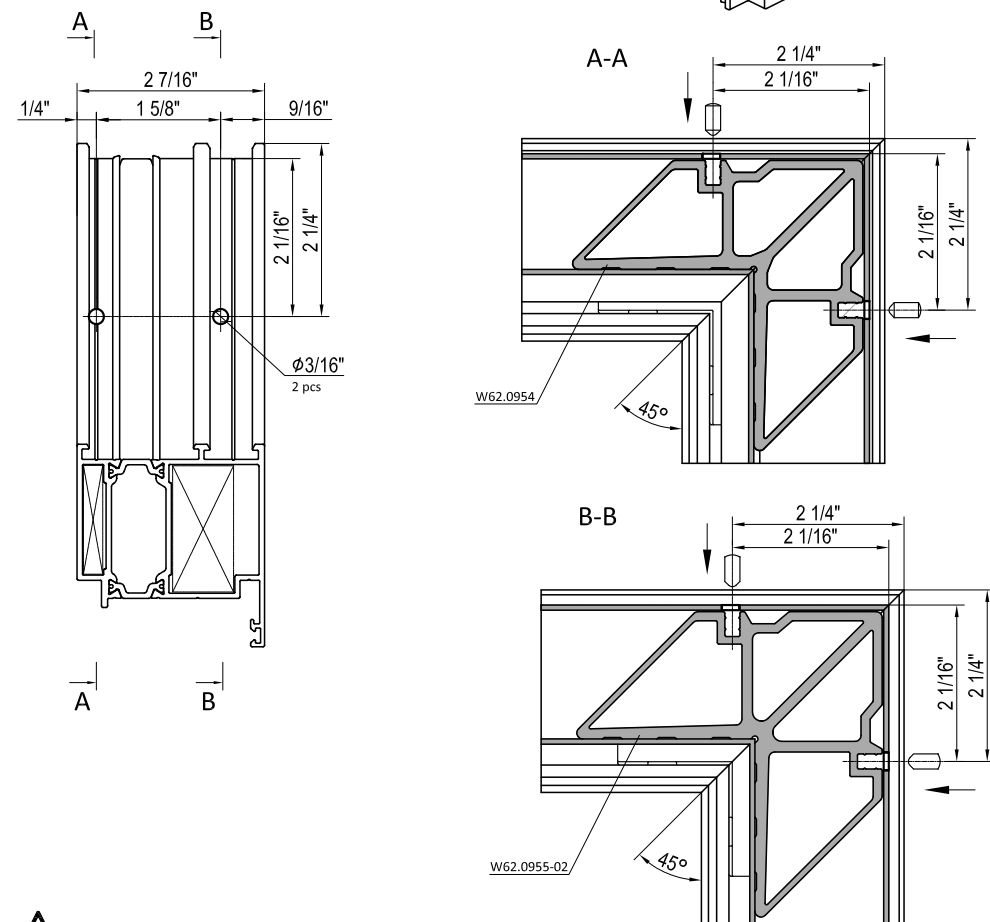
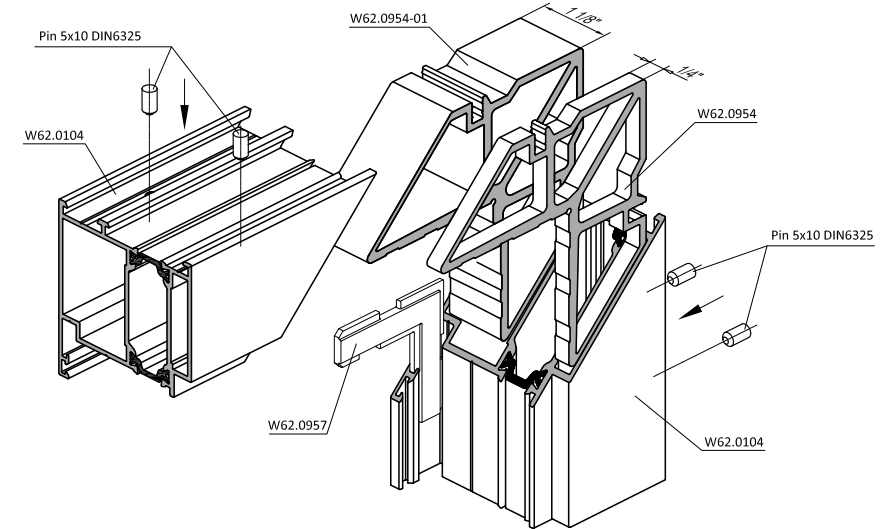

⚠ Apply Weiss Cosmopur 819 on inside moldings' surface

Corner key installation in W62.0204 moldings using crimping machine

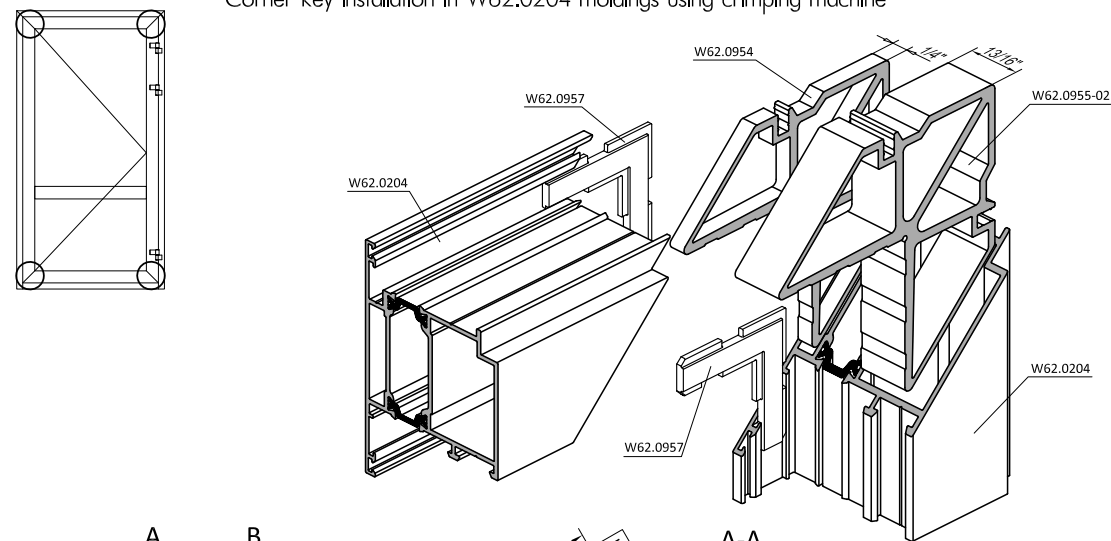

Corner key installation in W62.0204 moldings using pins

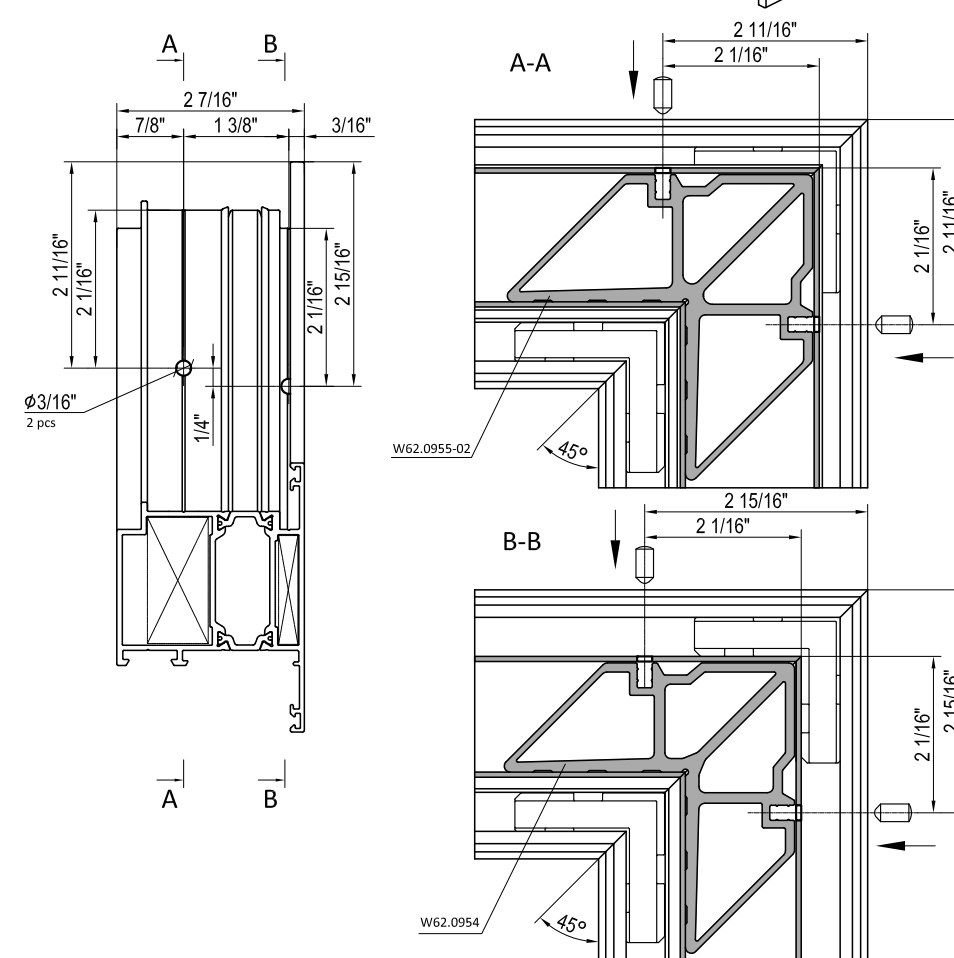
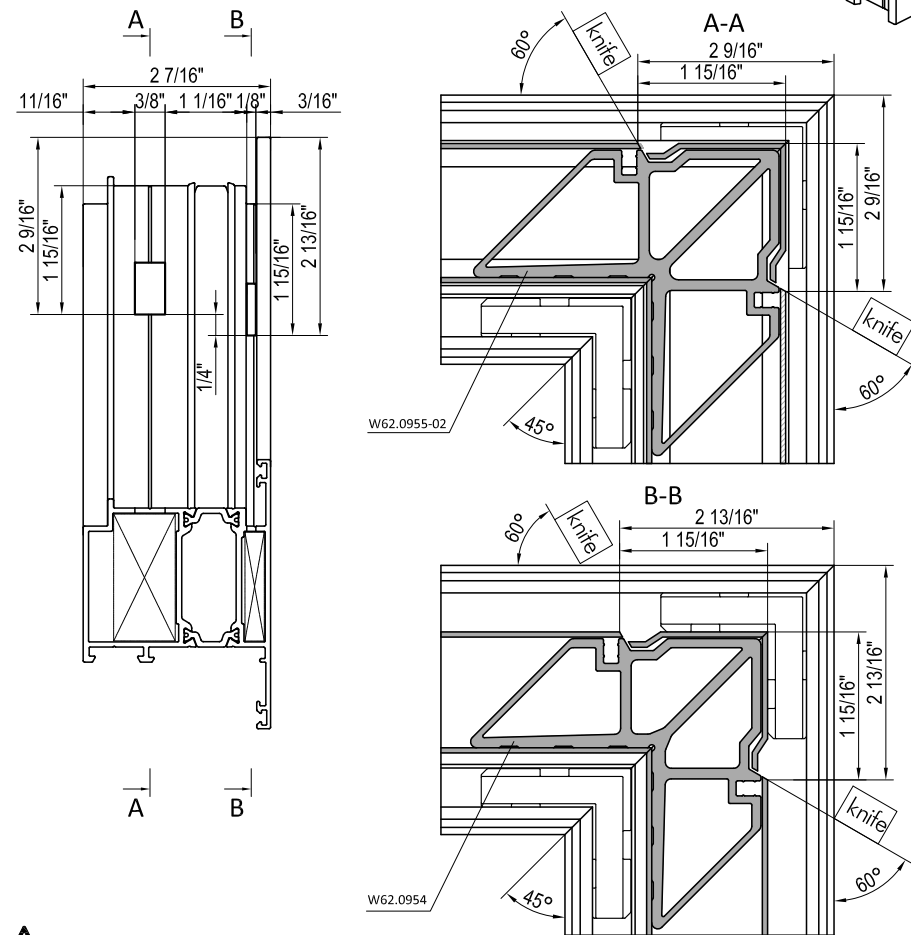
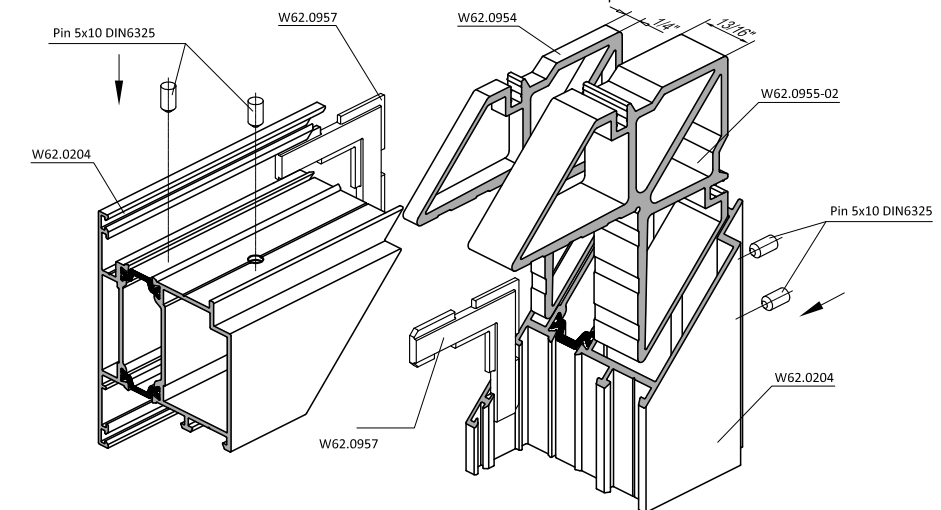

⚠ Apply Weiss Cosmopur 819 on inside moldings' surface

Corner key installation in W62.0204, W62.0205 moldings using crimping machine

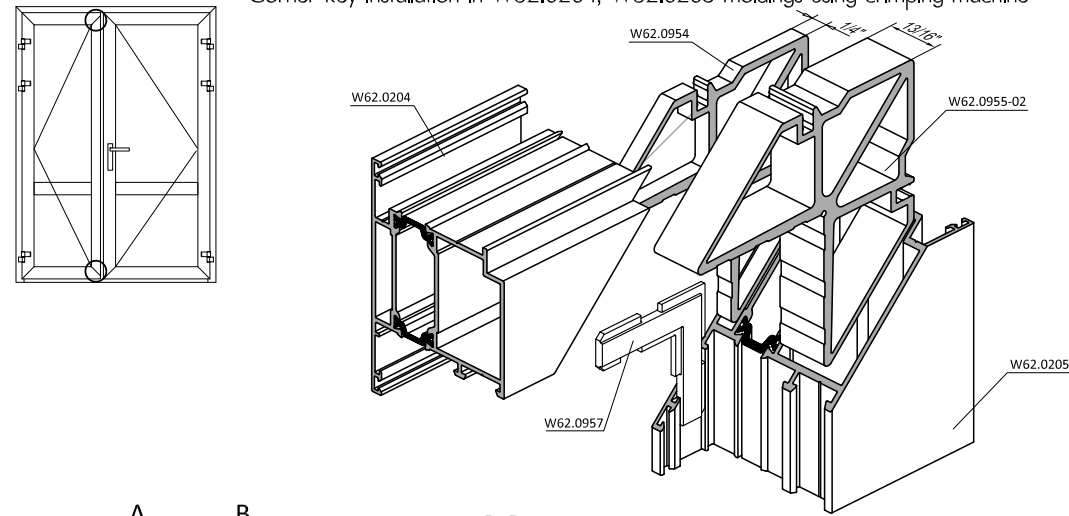

Corner key installation in W62.0204, W62.0205 moldings using pins

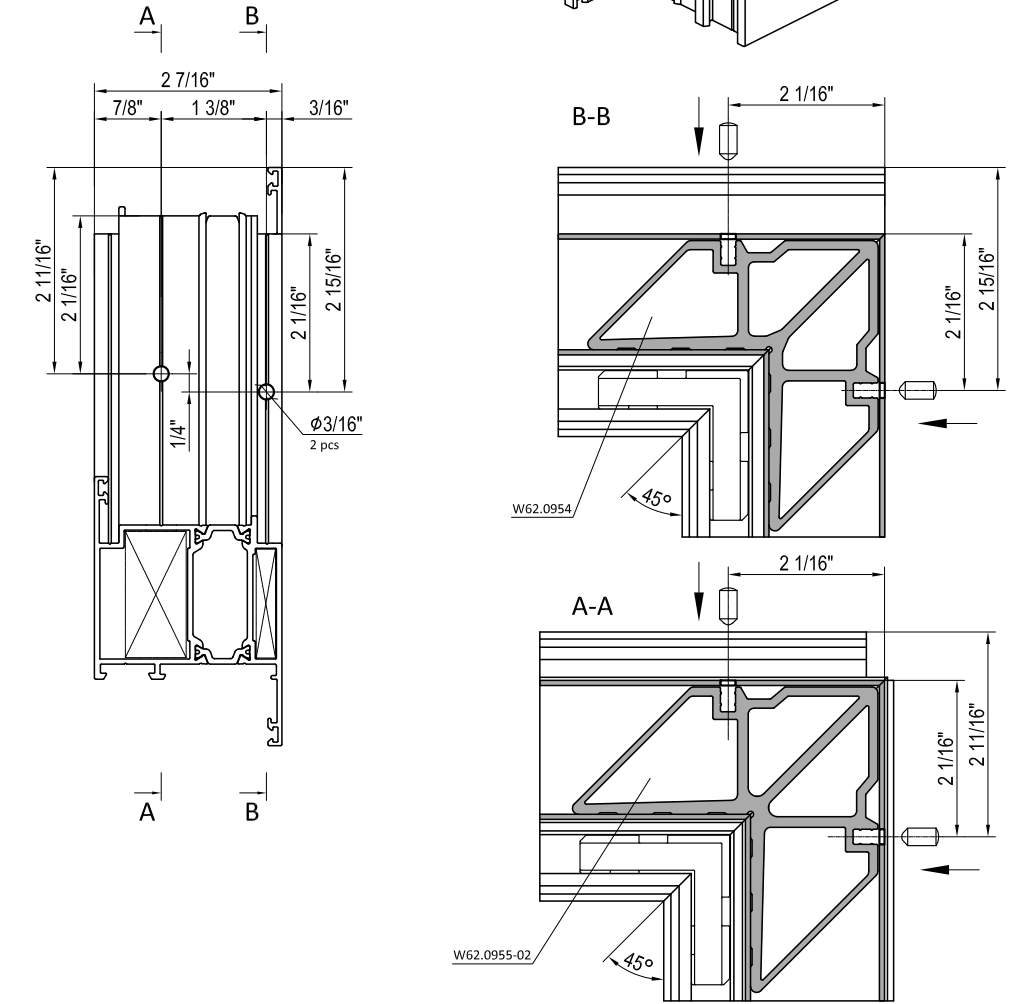
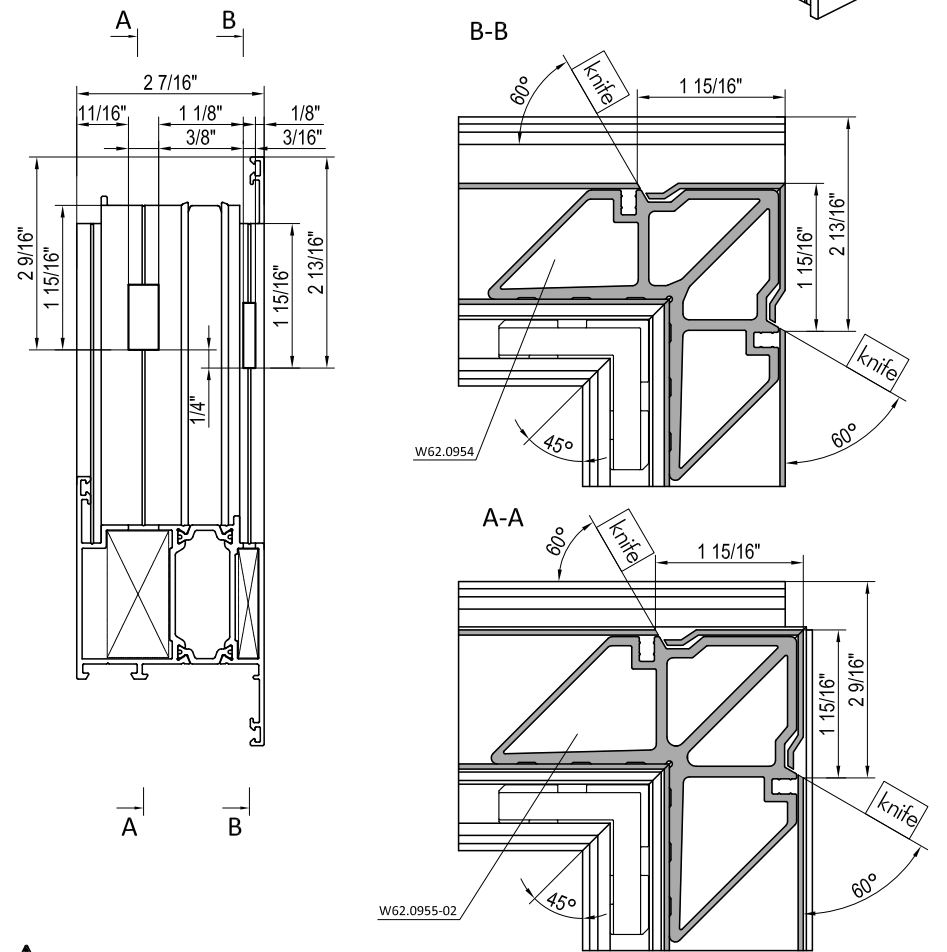
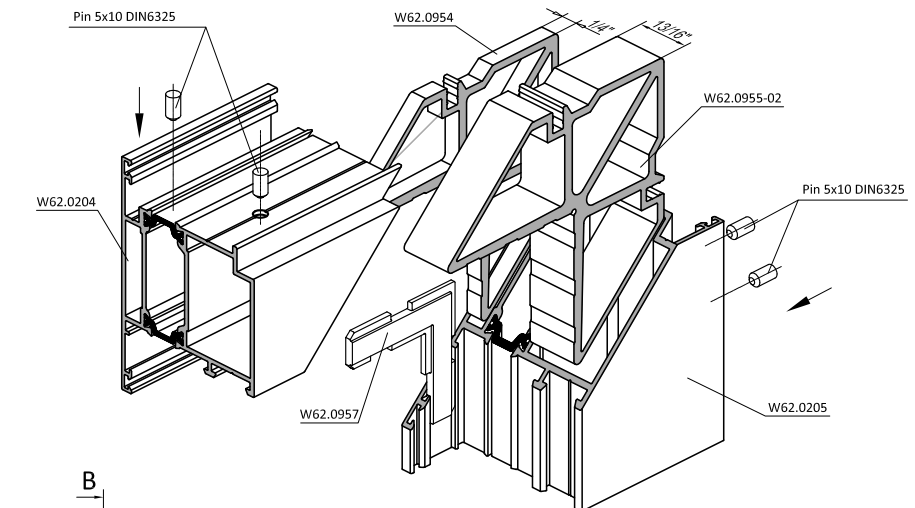

⚠ Apply Weiss Cosmopor 819 on inside moldings' surface

Corner key installation in W62.0105 moldings using crimping machine. Variant 1

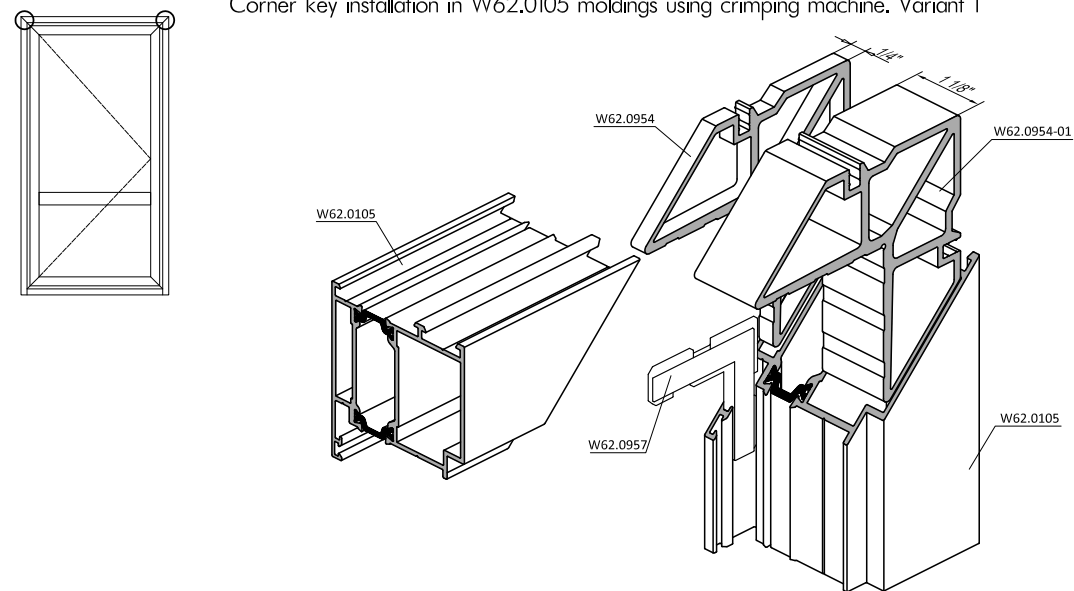

Corner key installation in W62.0105 moldings using crimping machine. Variant 2

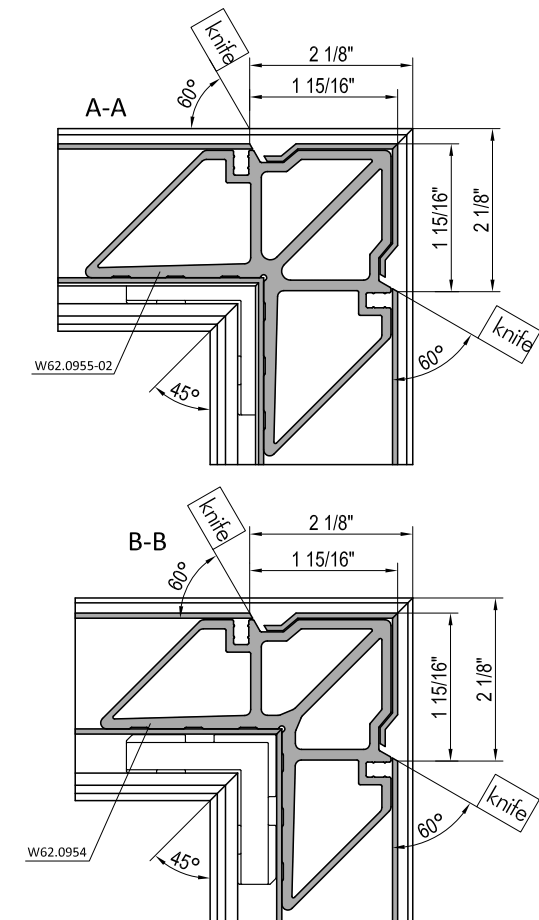
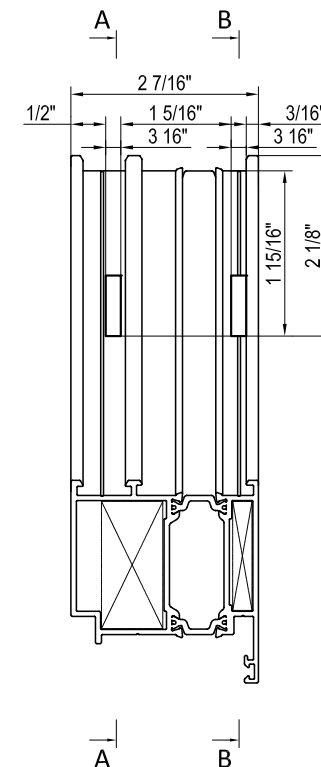
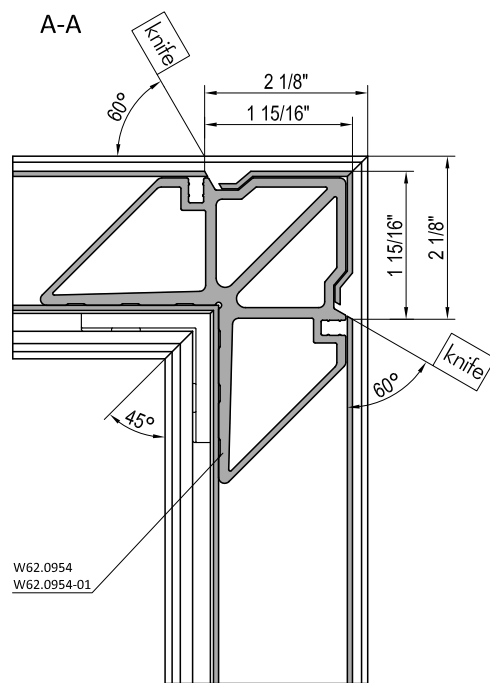
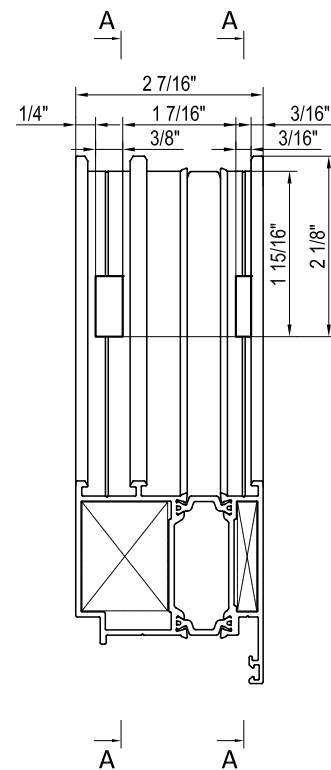
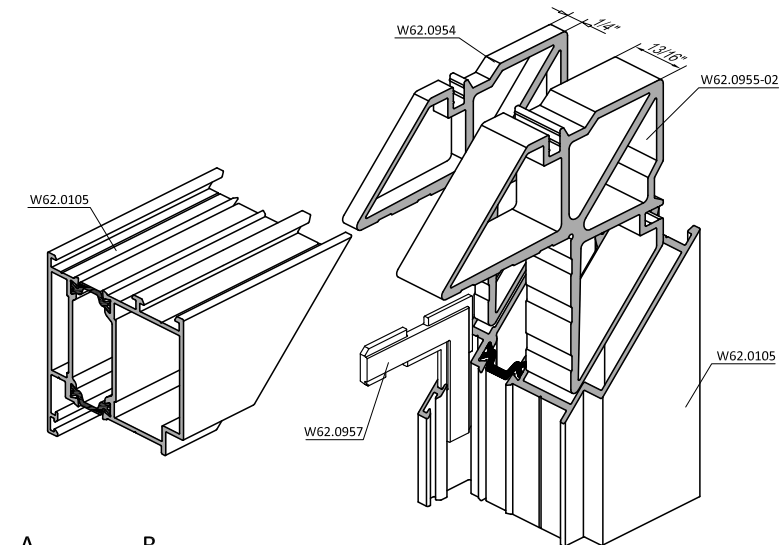

⚠ Apply Weiss Cosmopur 819 on inside moldings' surface

Corner key installation in W62.0105 moldings using pins. Variant 1

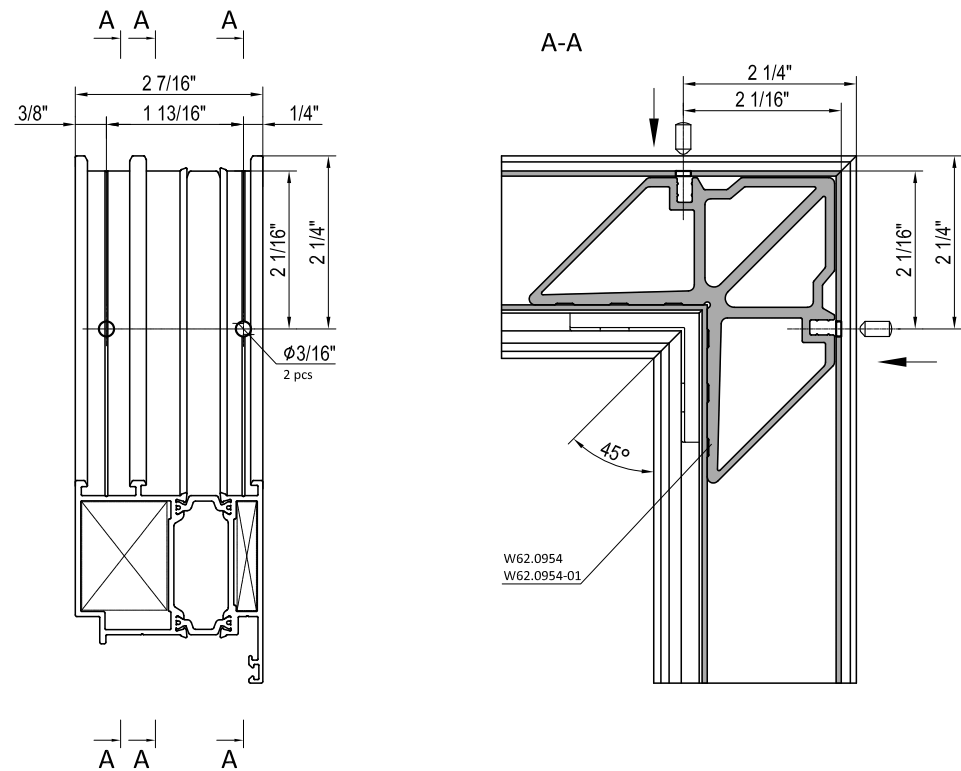
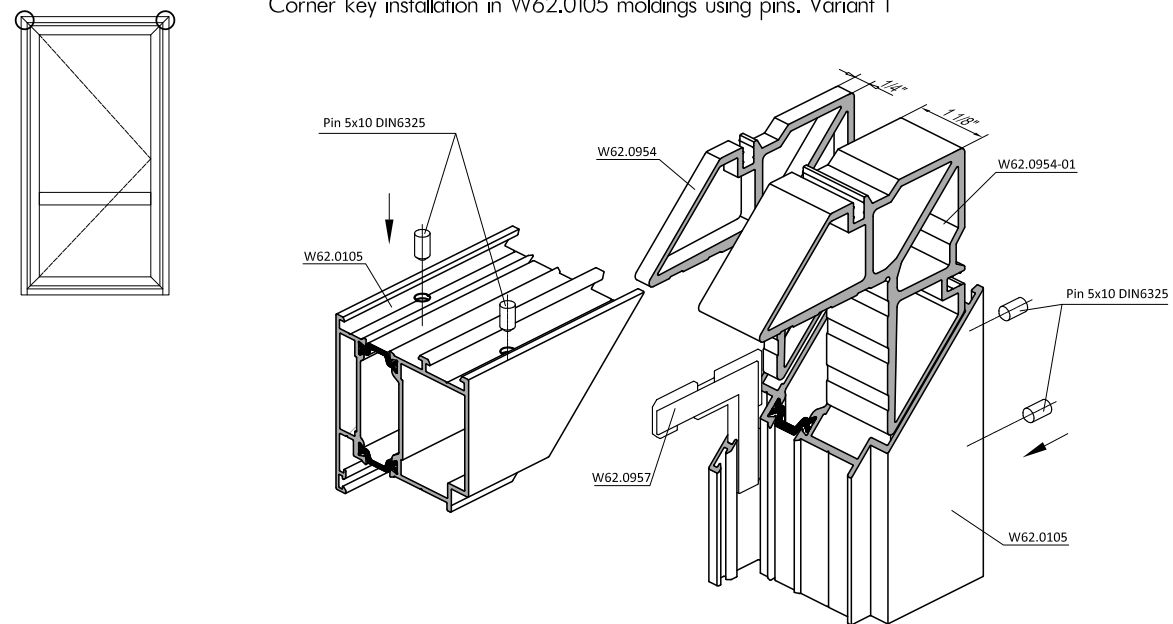

Corner key installation in W62.0105 moldings using pins. Variant 2

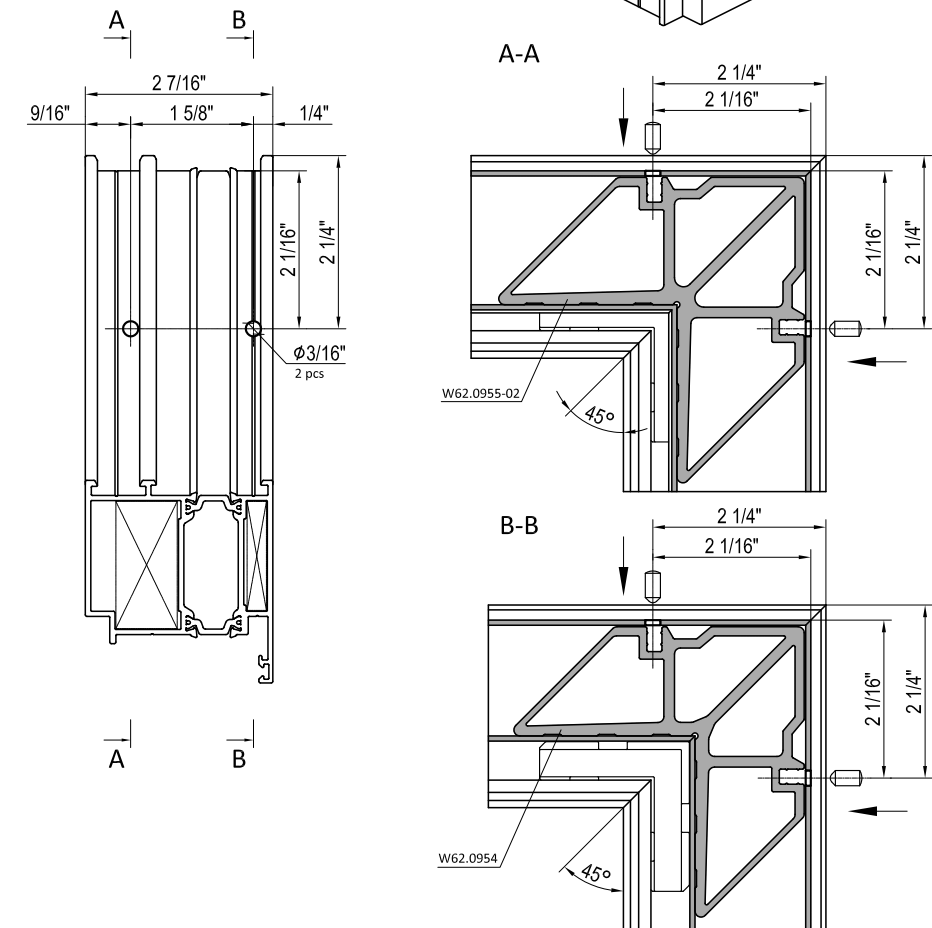
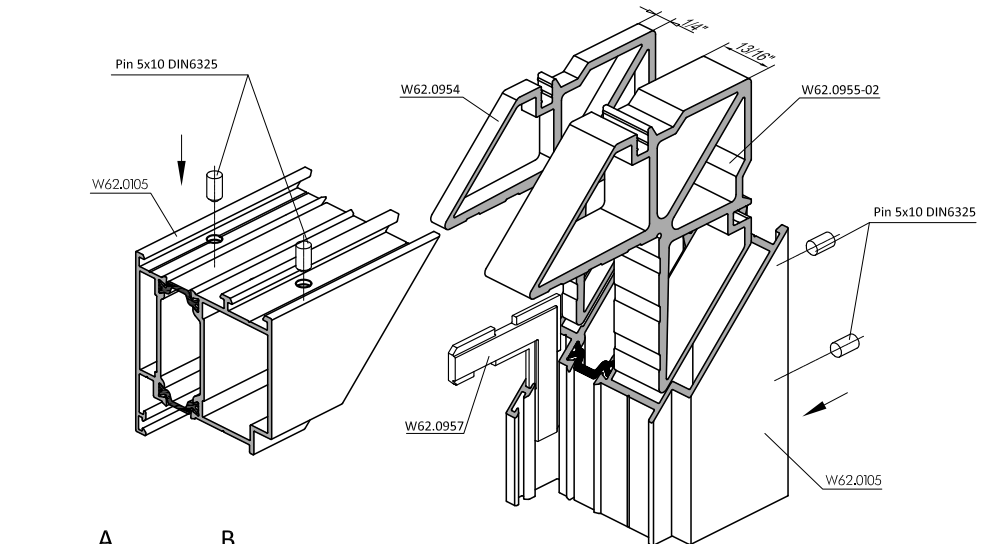

⚠ Apply Weiss Cosmopur 819 on inside moldings' surface

Corner key installation in W62.0205 moldings using crimping machine

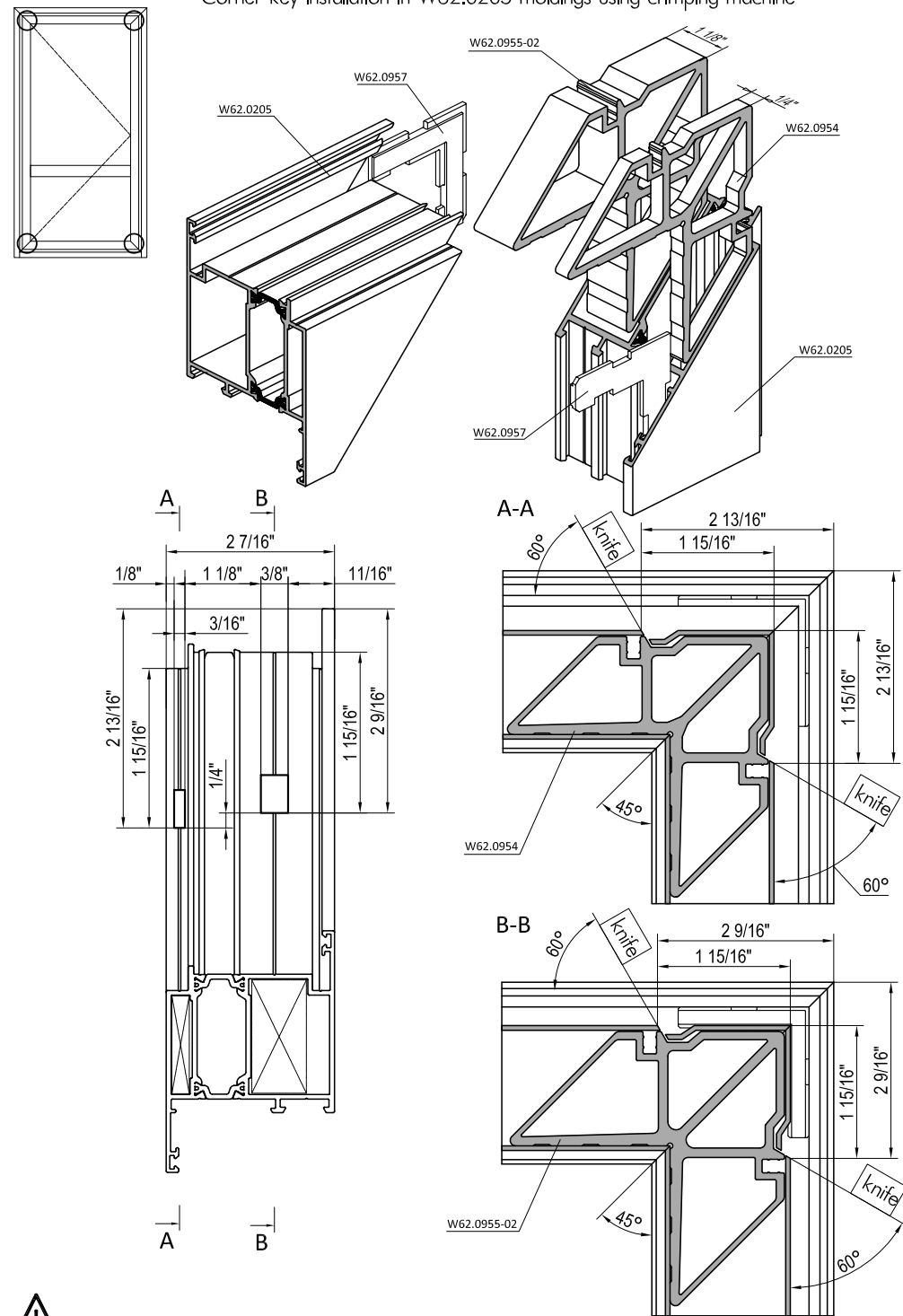

Apply Weiss Cosmopur 819 on inside moldings' surface

Corner key installation in W62.0205 moldings using pins

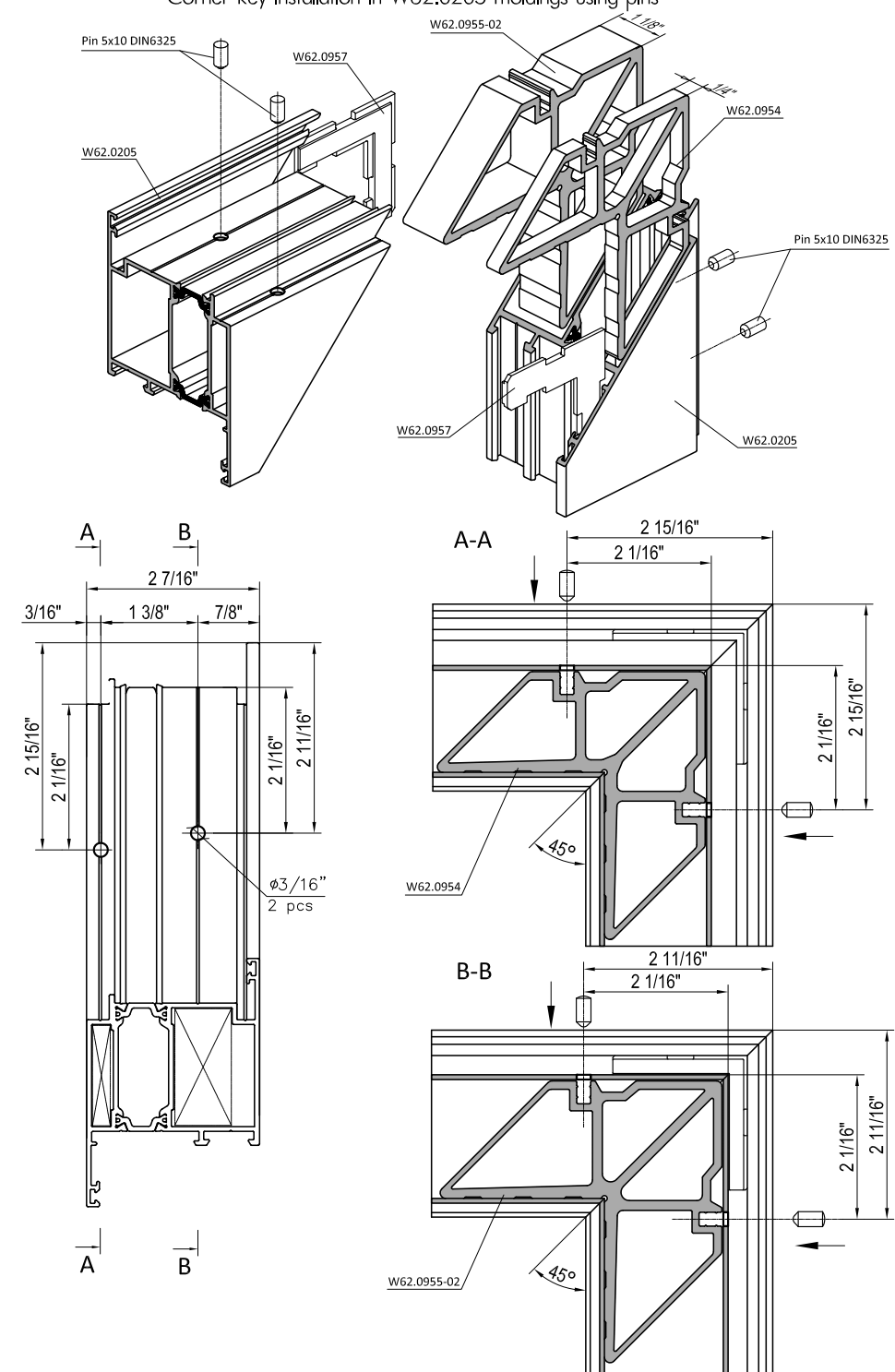

Corner key installation in W62.0205, W62.0204 moldings using pins

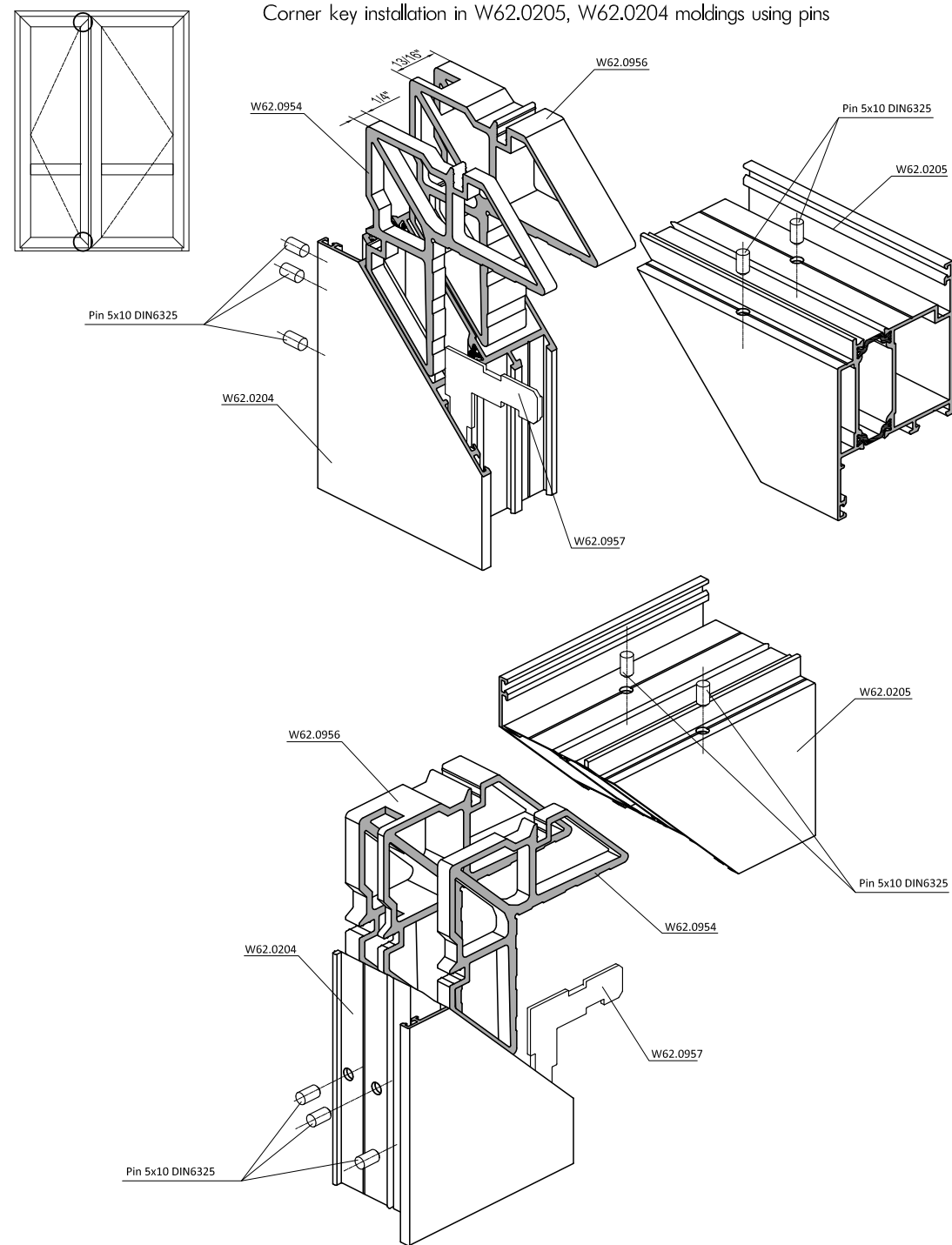

⚠ Apply Weiss Cosmopur 819 on inside moldings' surface

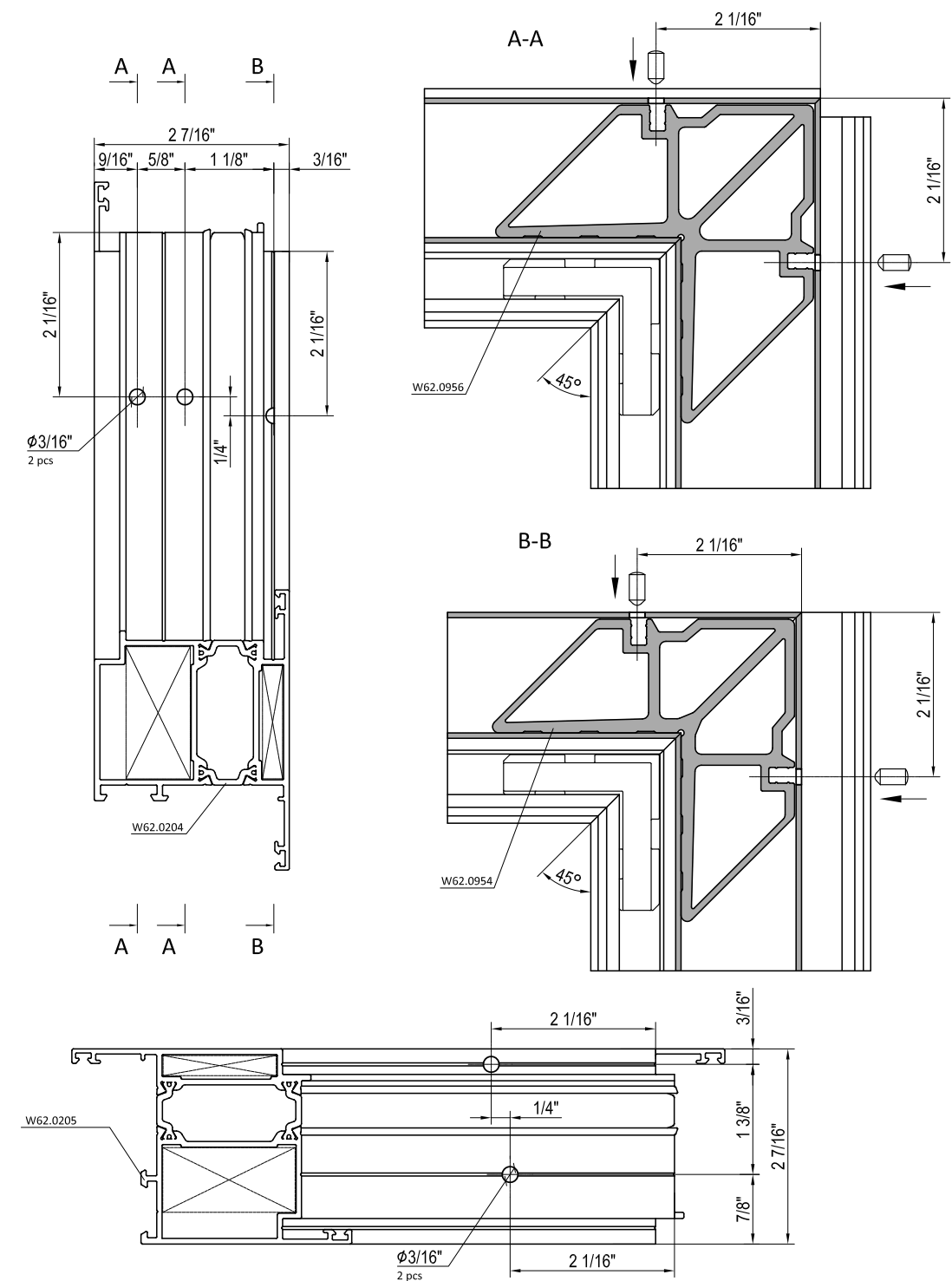

Corner key installation in W62.0205, W62.0204 moldings using crimping machine

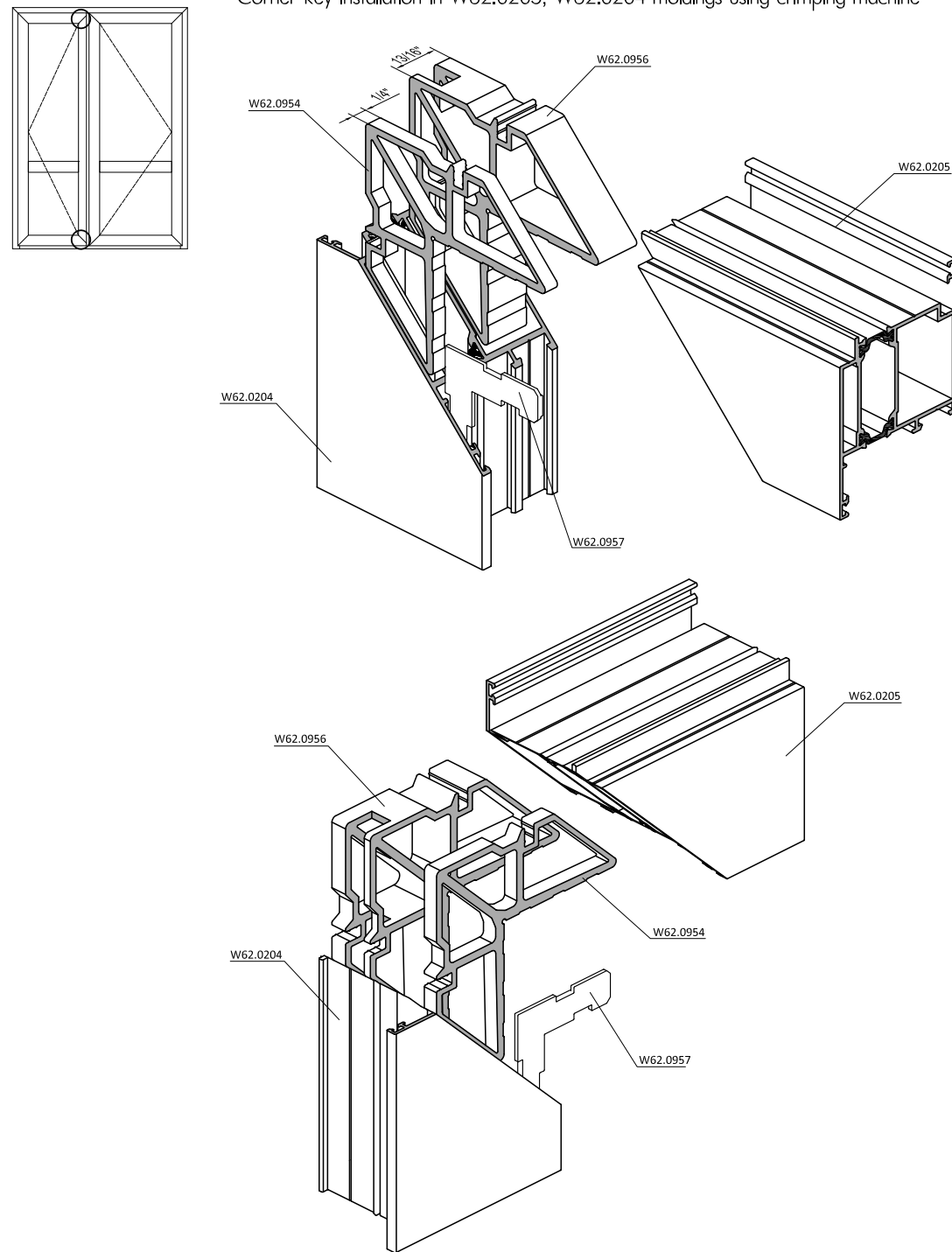

⚠ Apply Weiss Cosmopor 819 on inside moldings' surface

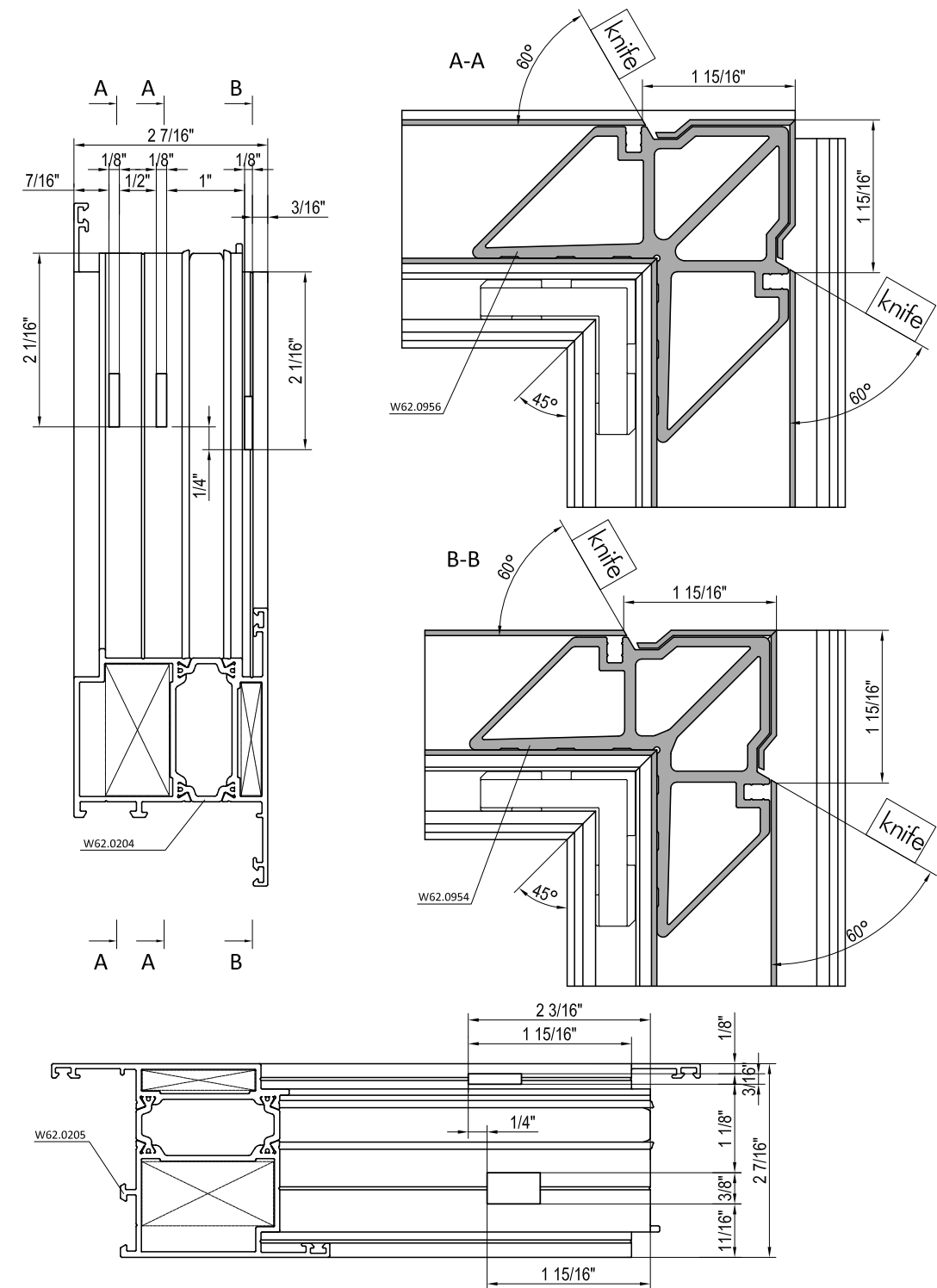

Corner key installation in W62.0805 moldings using crimping machine

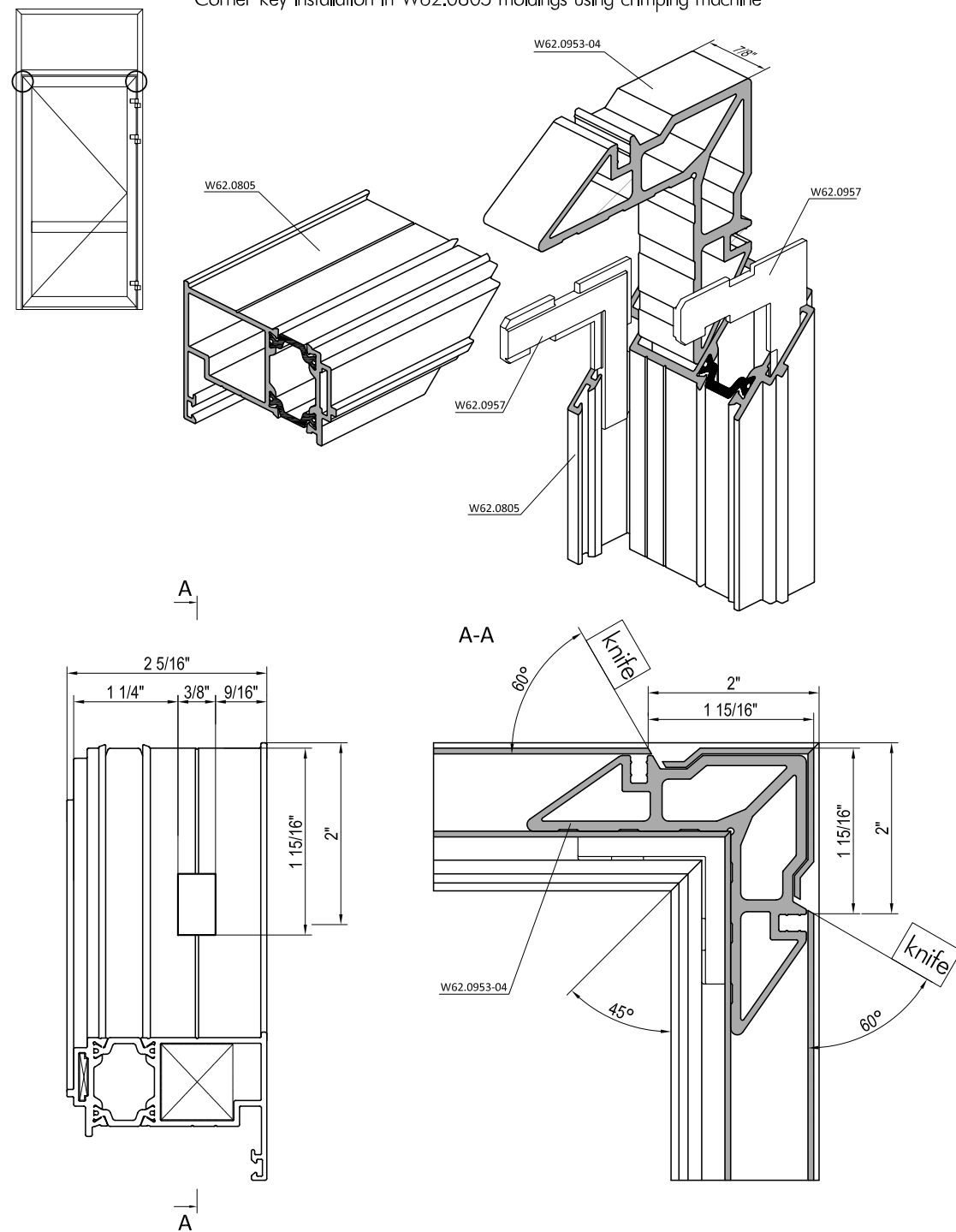

⚠ Apply Weiss Cosmopor 819 on inside moldings' surface

Corner key installation in W62.0805 moldings using pins

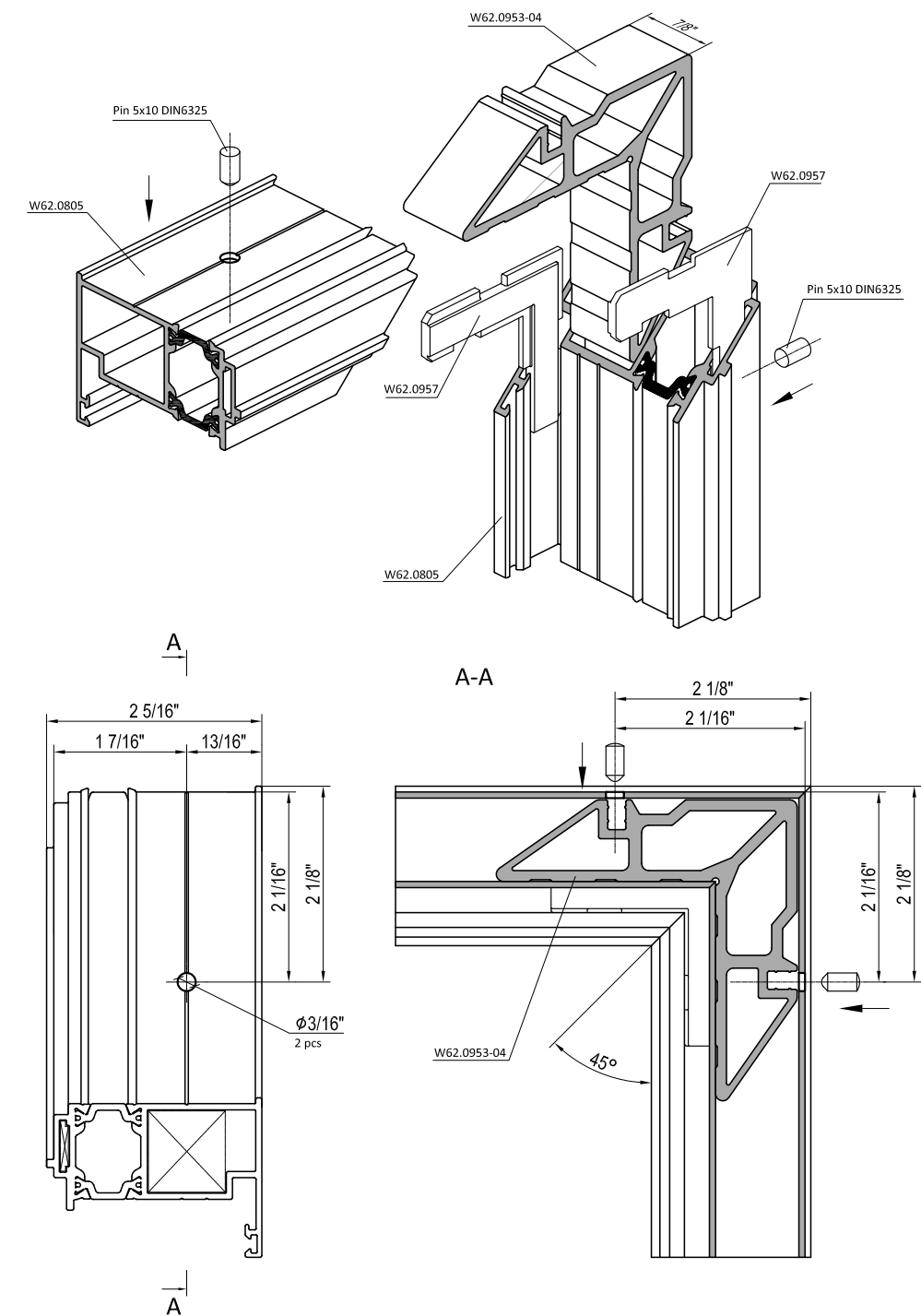

Typical fabrication and assembly of active door

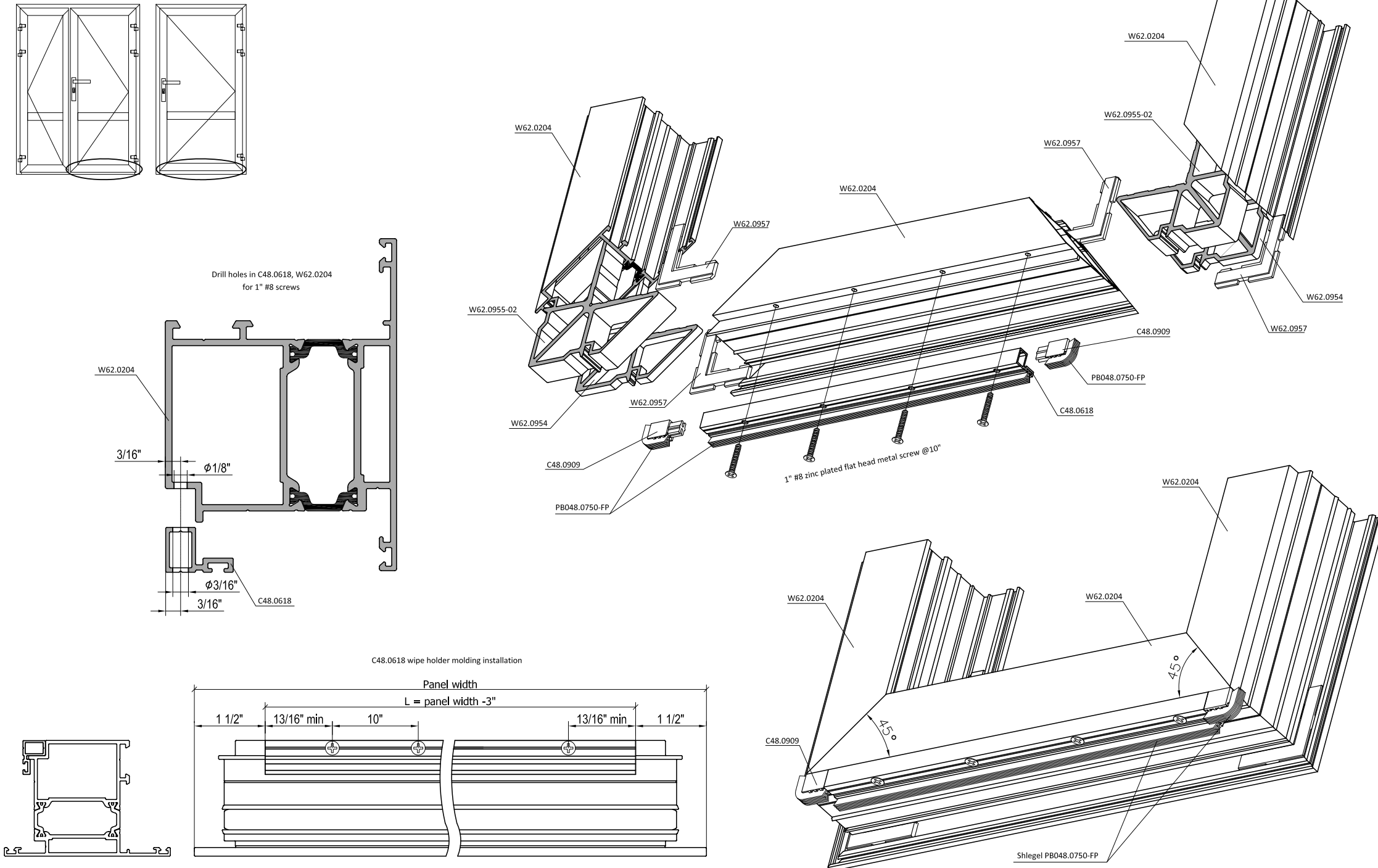

Typical fabrication of active door

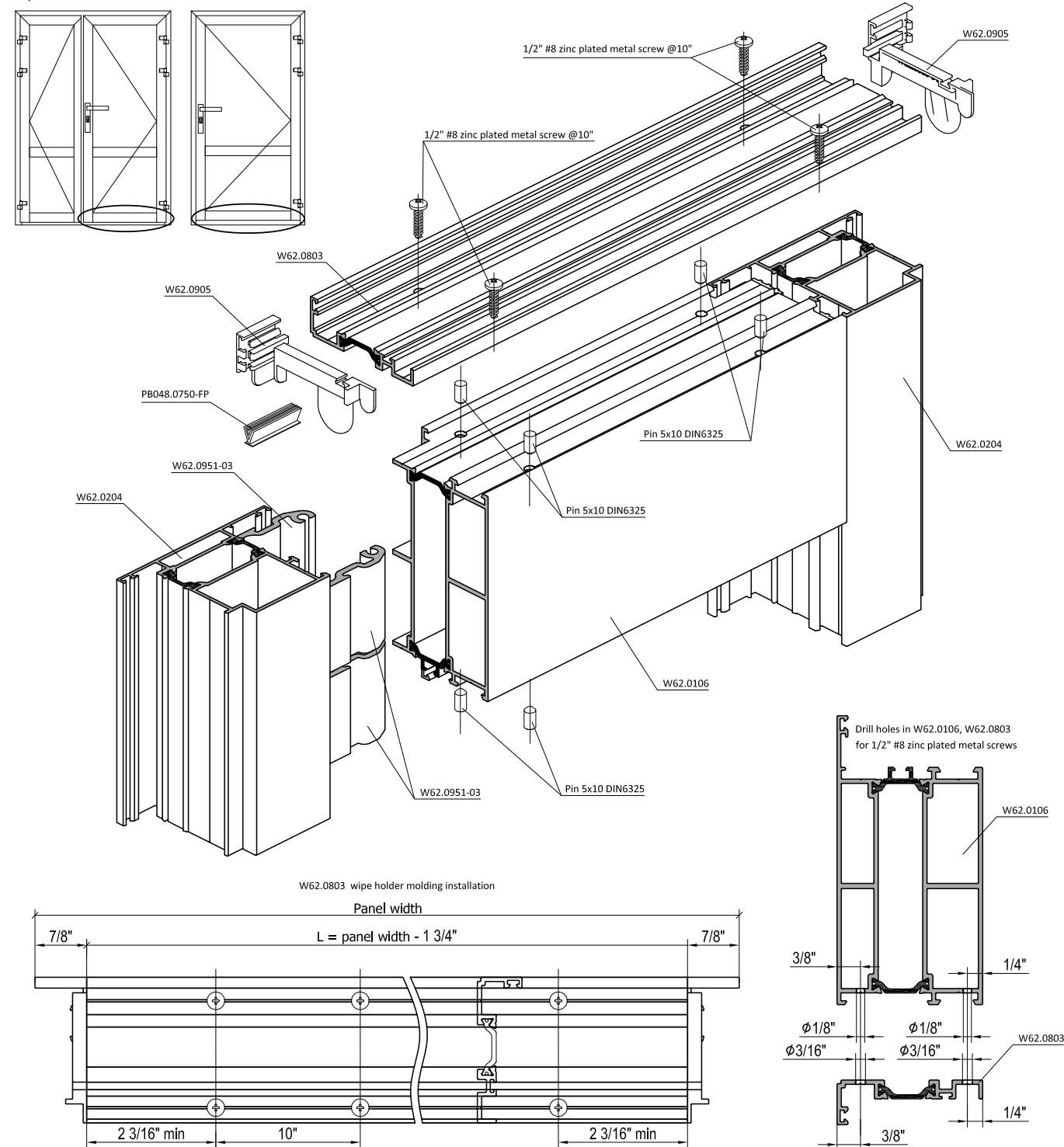

Inserts installation scheme

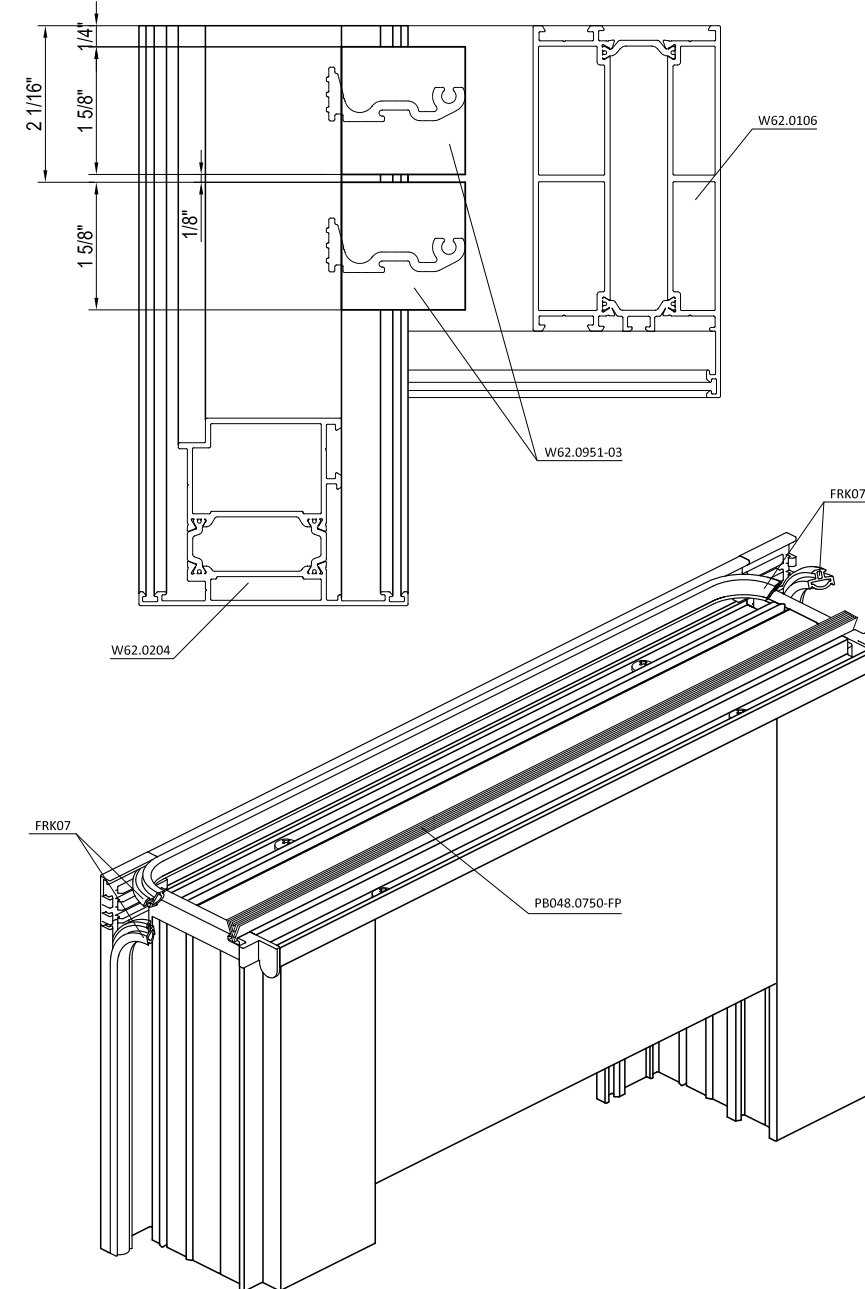

Typical fabrication and assembly of active door bottom molding

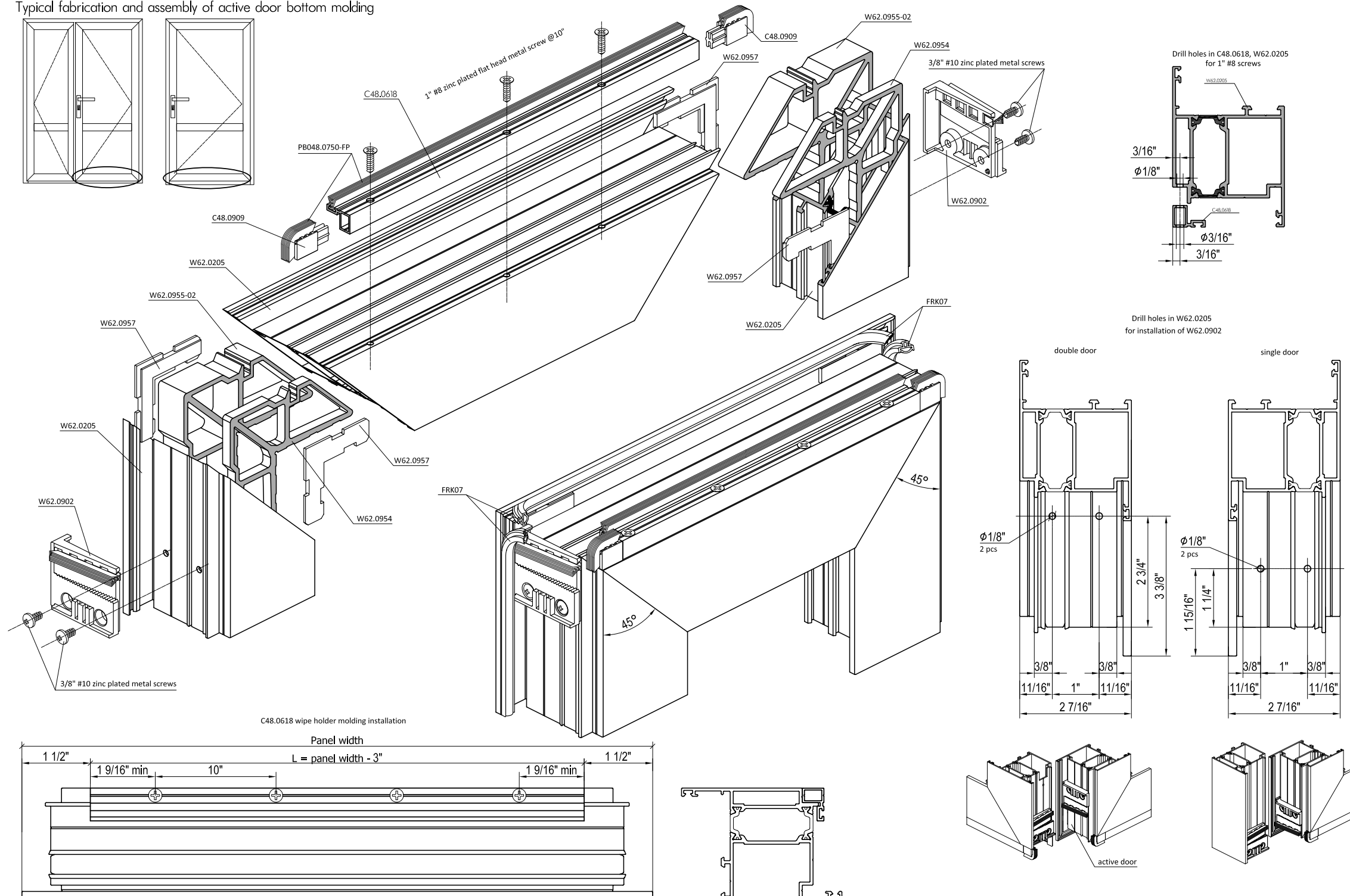

Typical fabrication and assembly of passive door

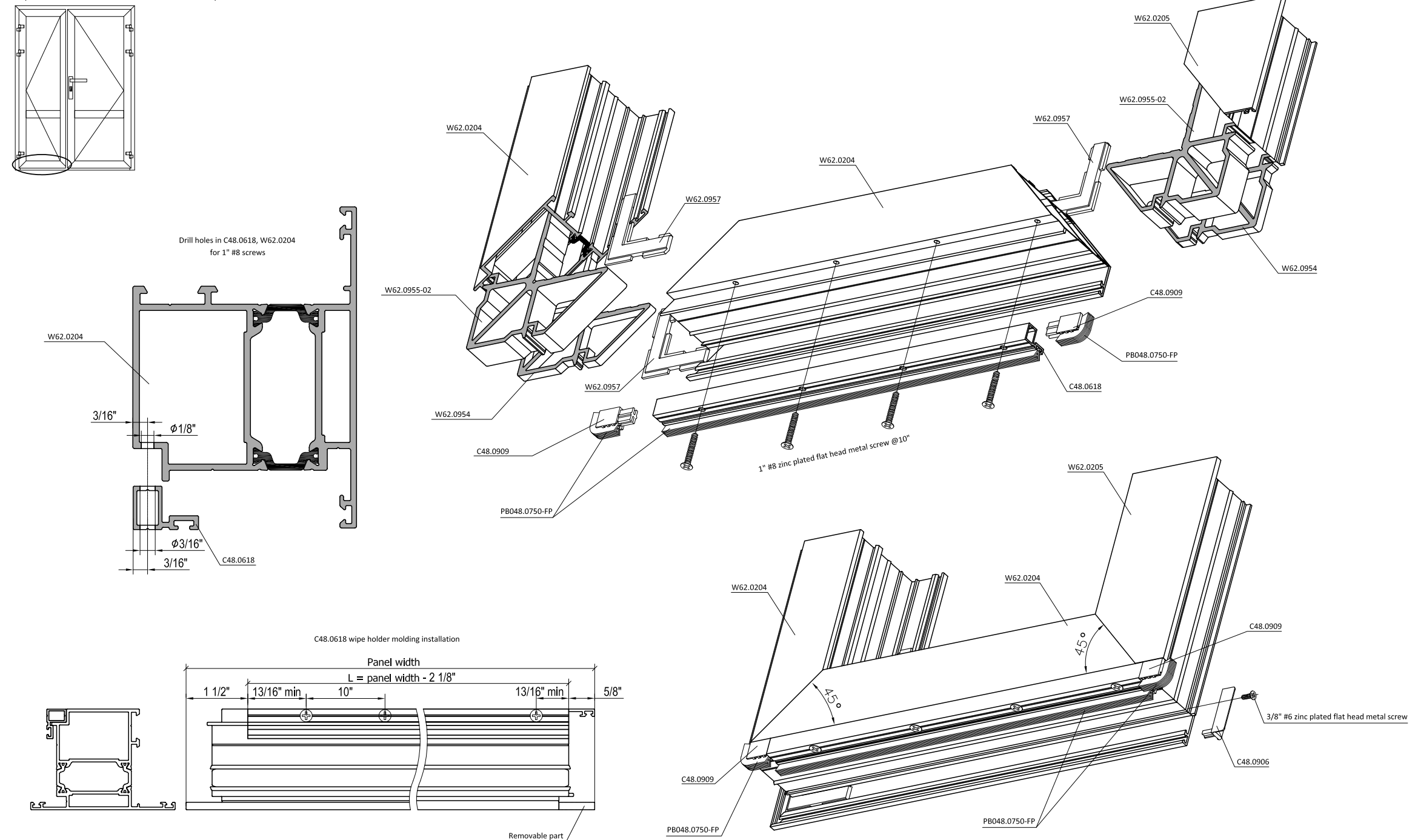

⚠ Cut profiles W62.0204, W62.0205 prior to fabrication

Typical fabrication and assembly of passive door

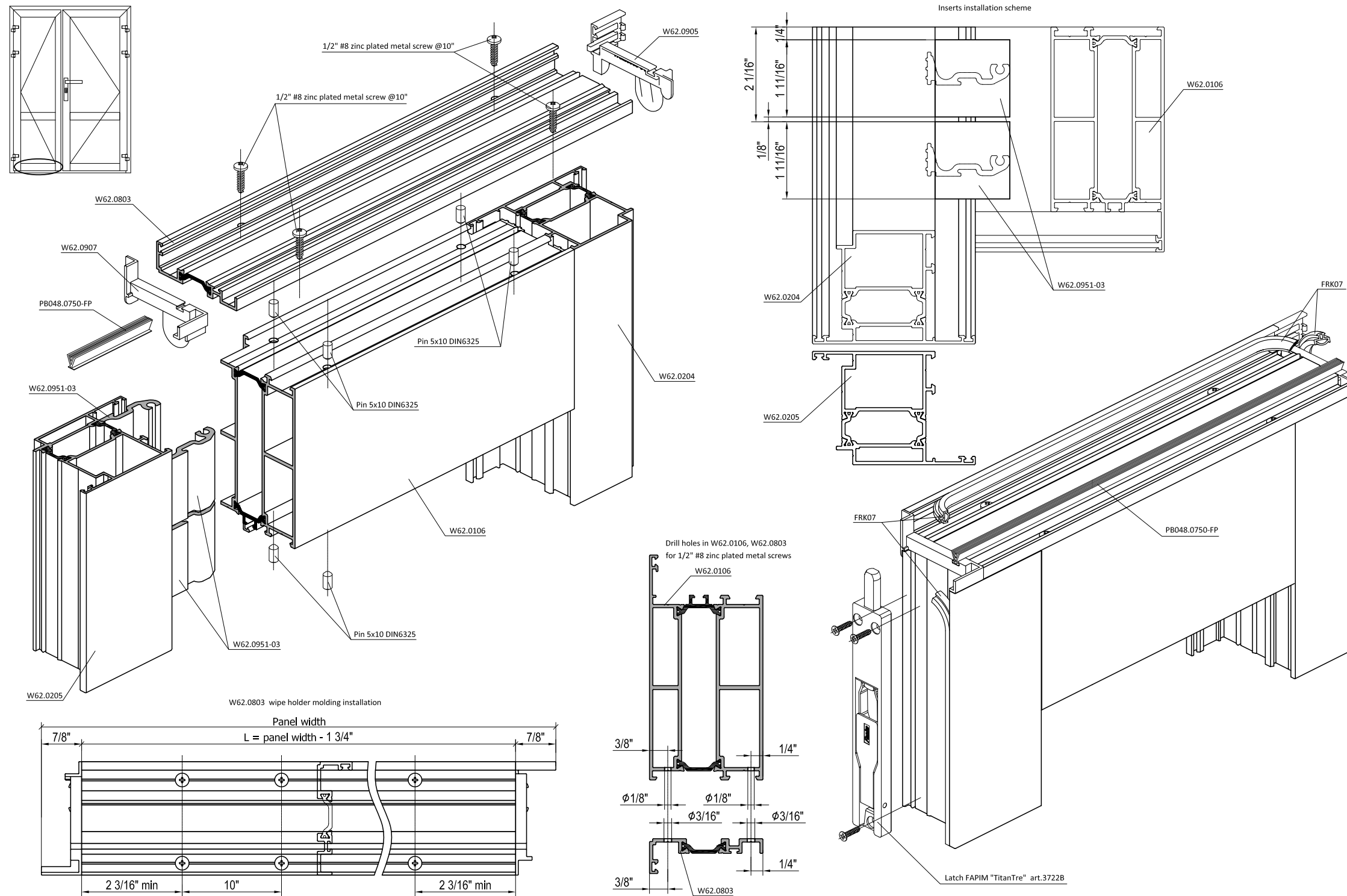

Typical assembly of passive door with adaptor molding W62.0502

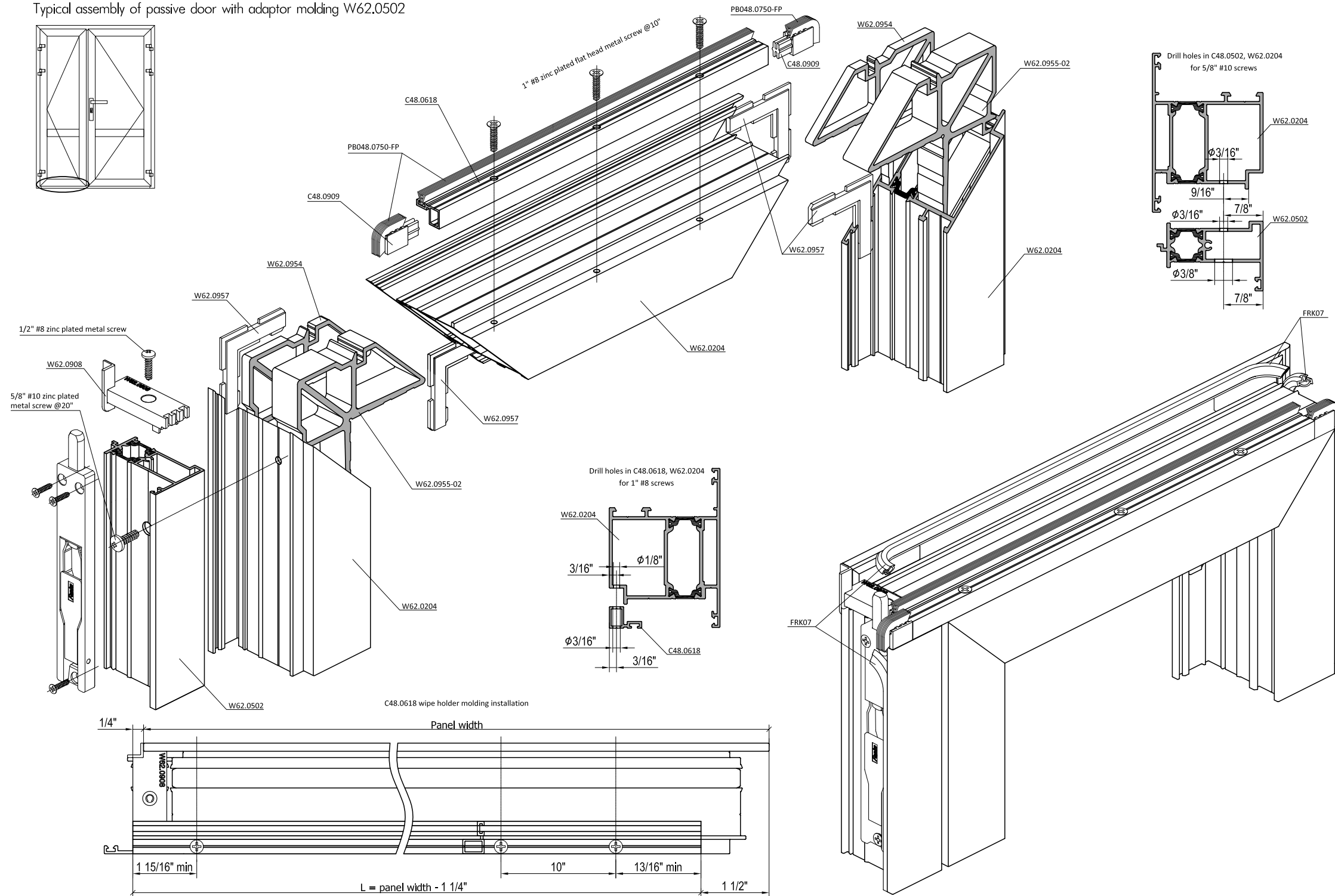

Typical fabrication and assembly of passive door

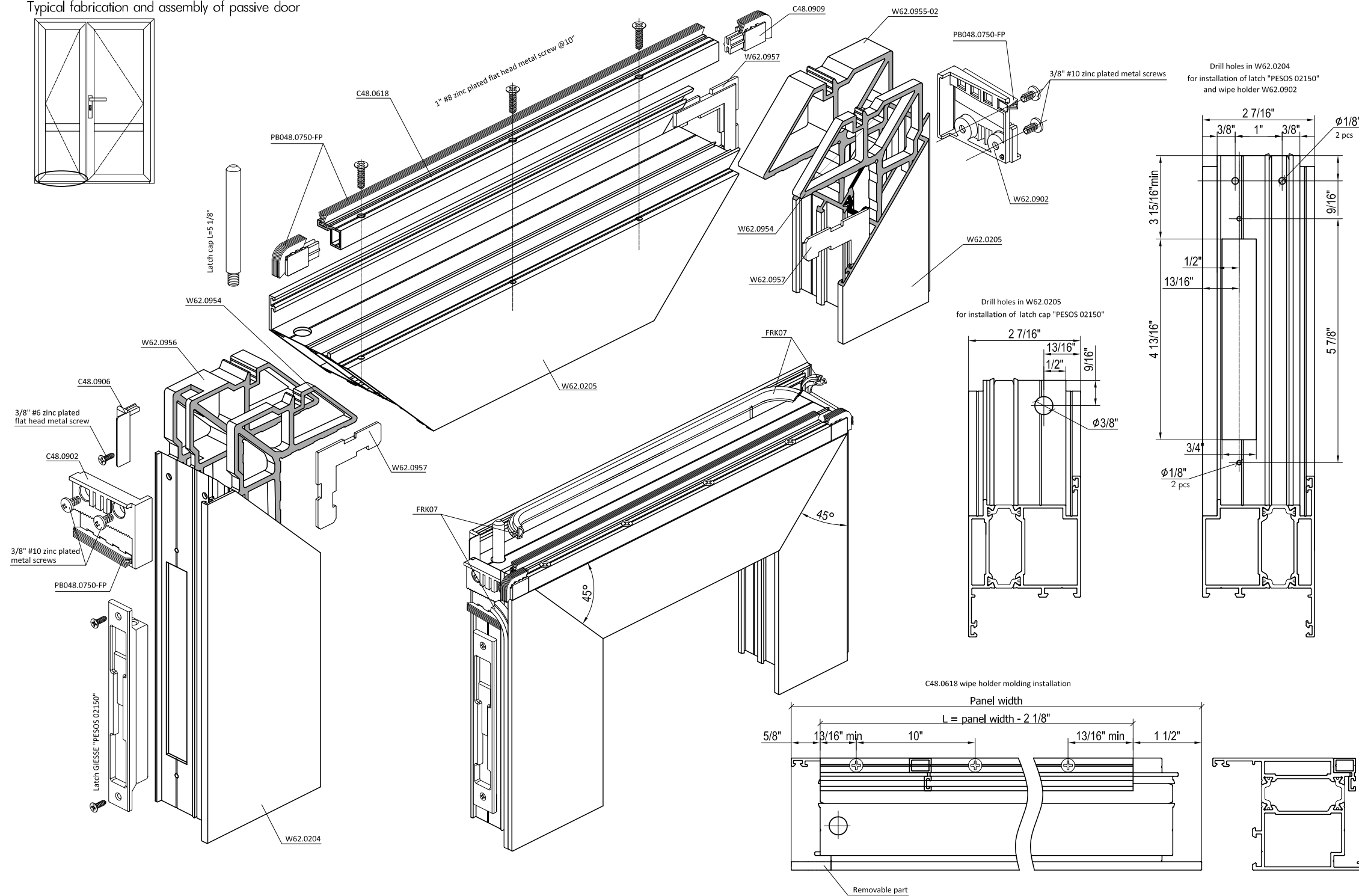

Typical fabrication and assembly of passive door top moldings without adaptor molding

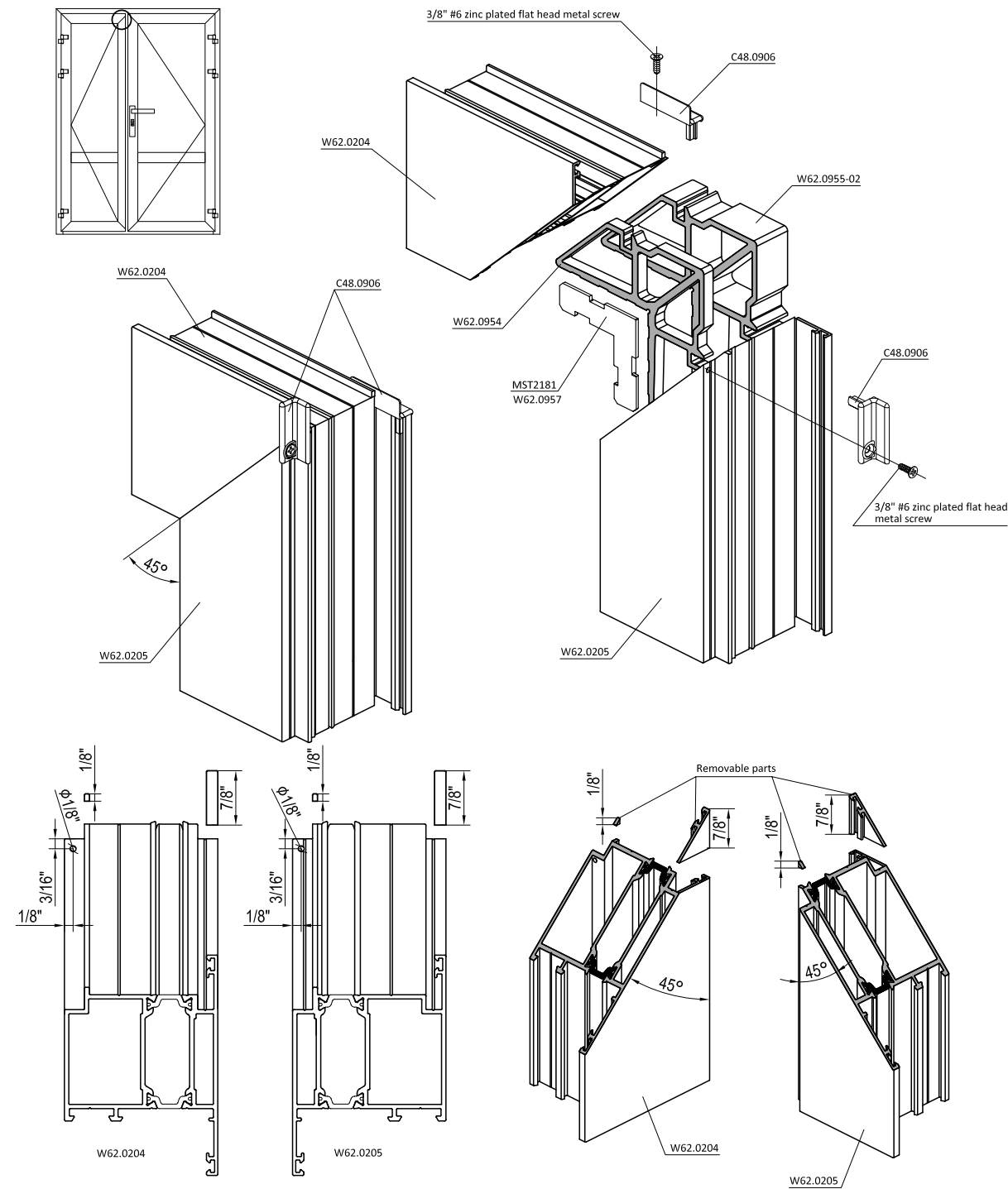

Typical fabrication and assembly of passive door top moldings with adaptor molding W62.0502

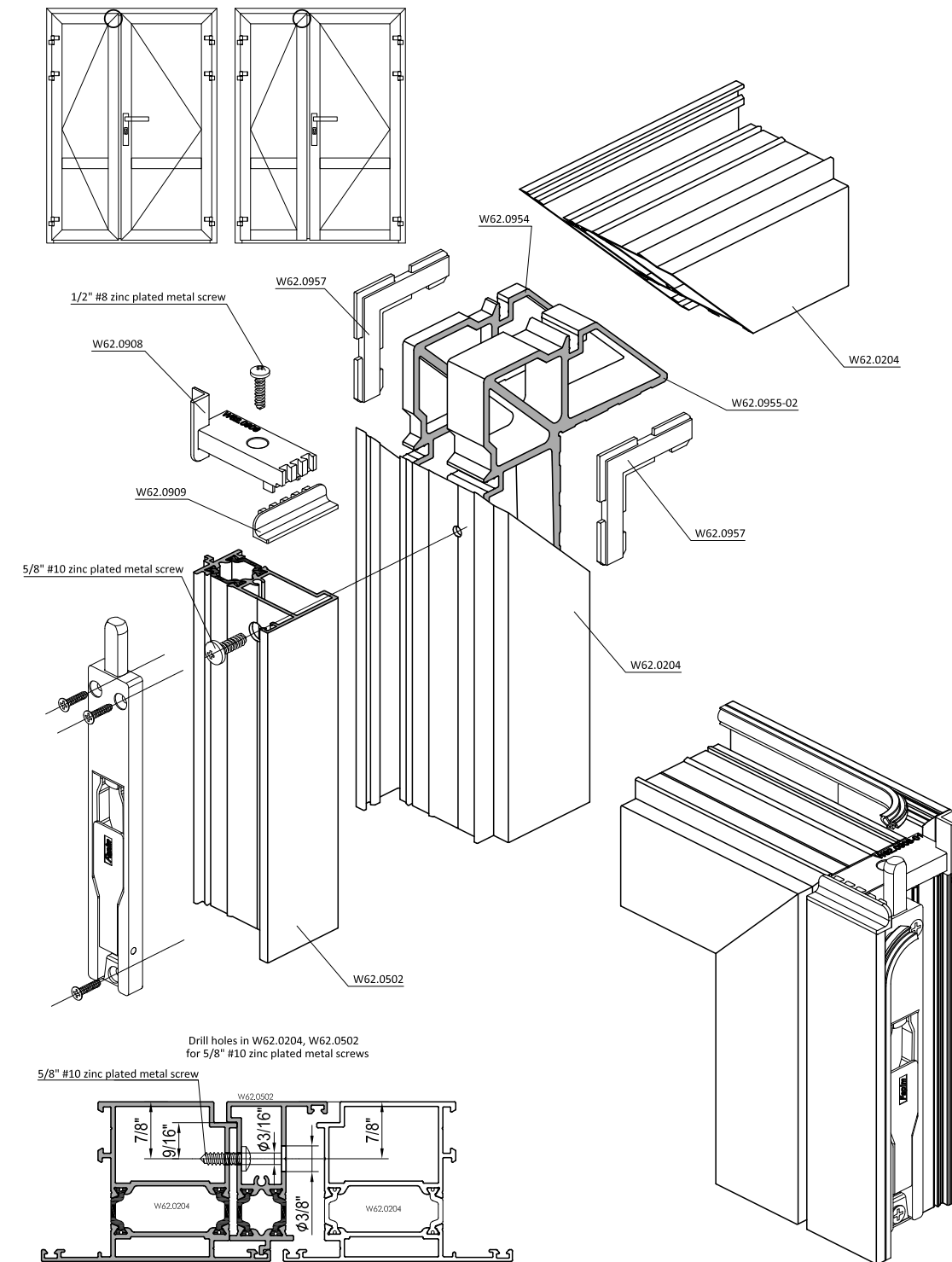

Typical fabrication and assembly of passive door top moldings

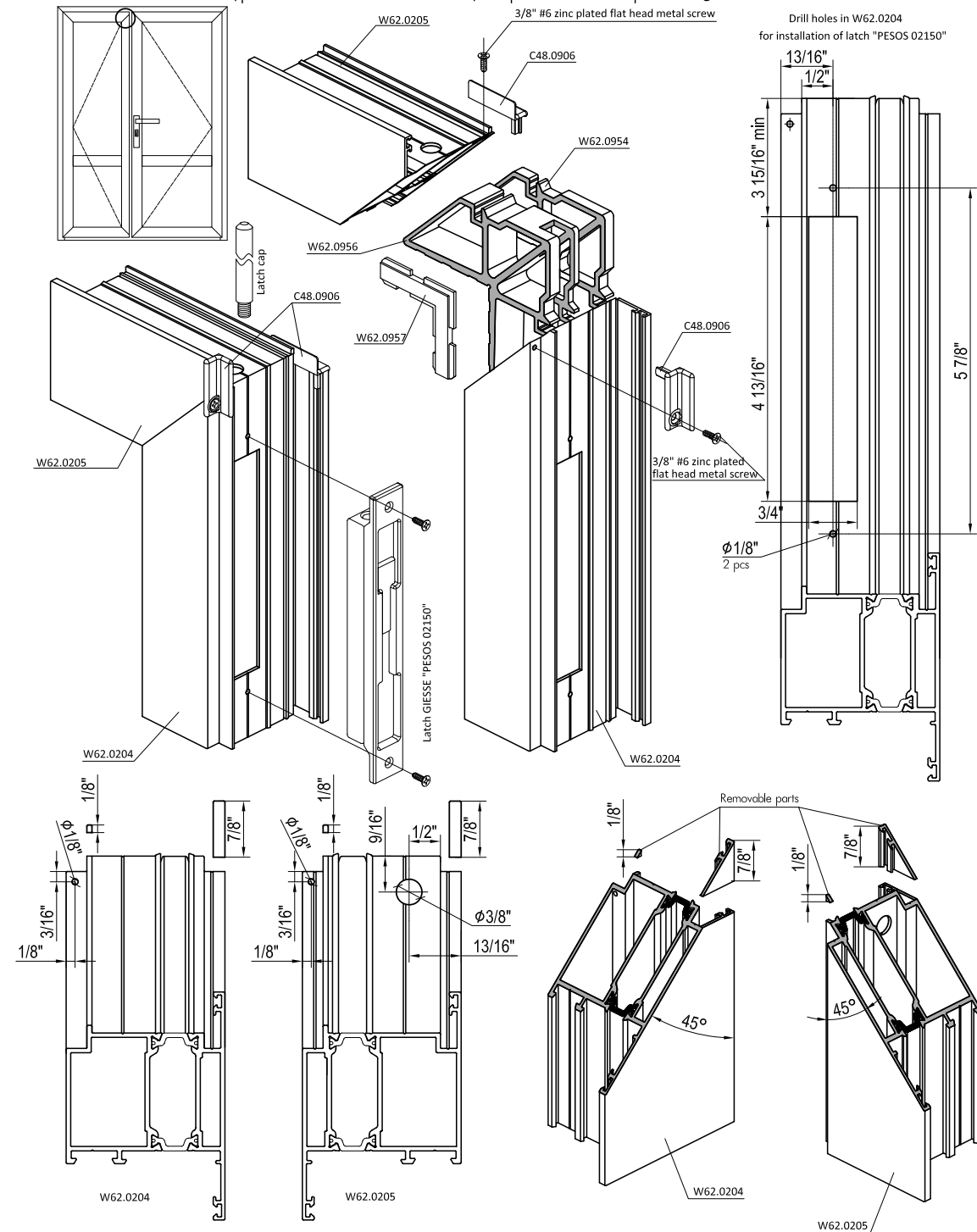

Typical fabrication and assembly of entrance unit with swing out door

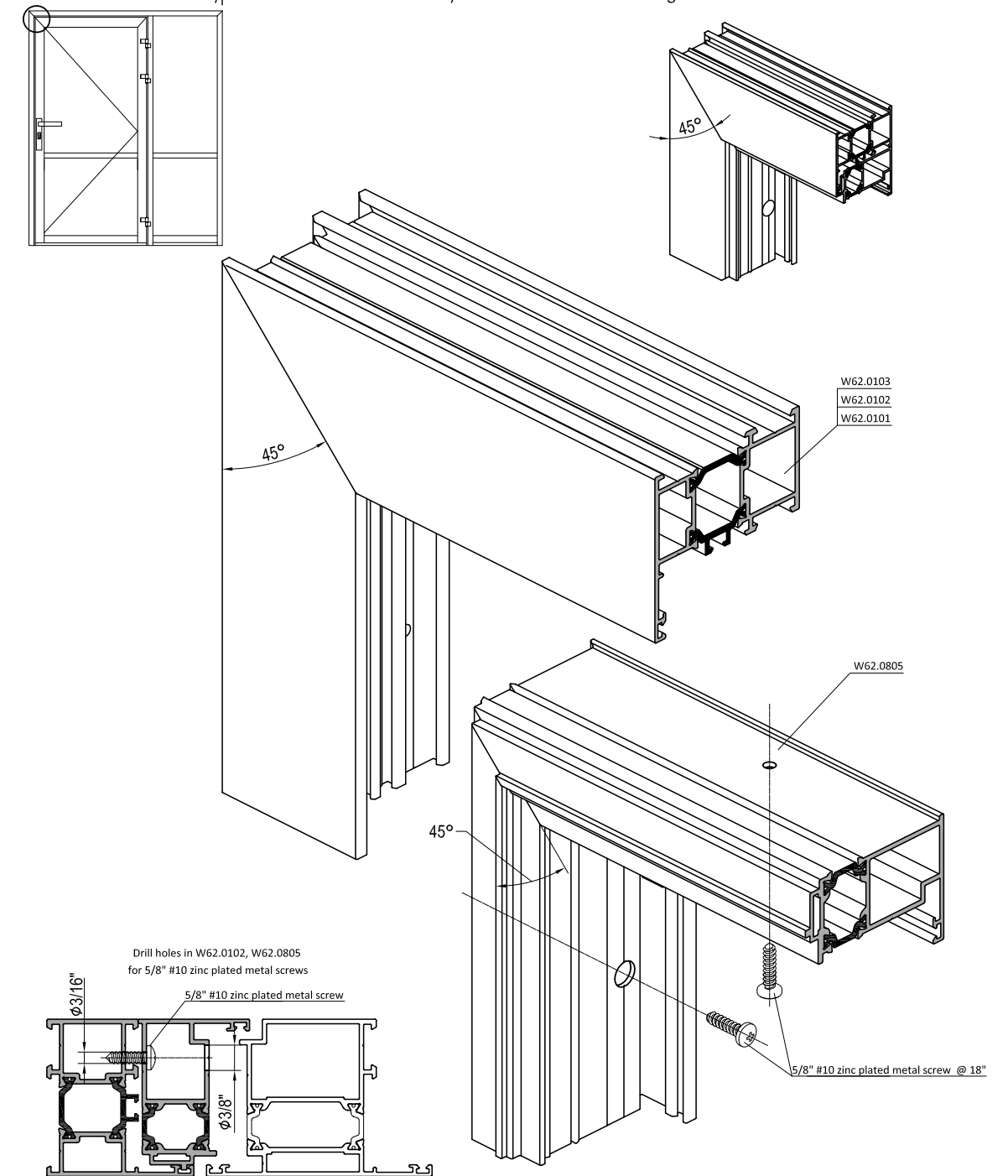

⚠ Do not install surface mounted hinges on W62.0101 molding

Typical fabrication and assembly of entrance unit with swing out door and fixed lite

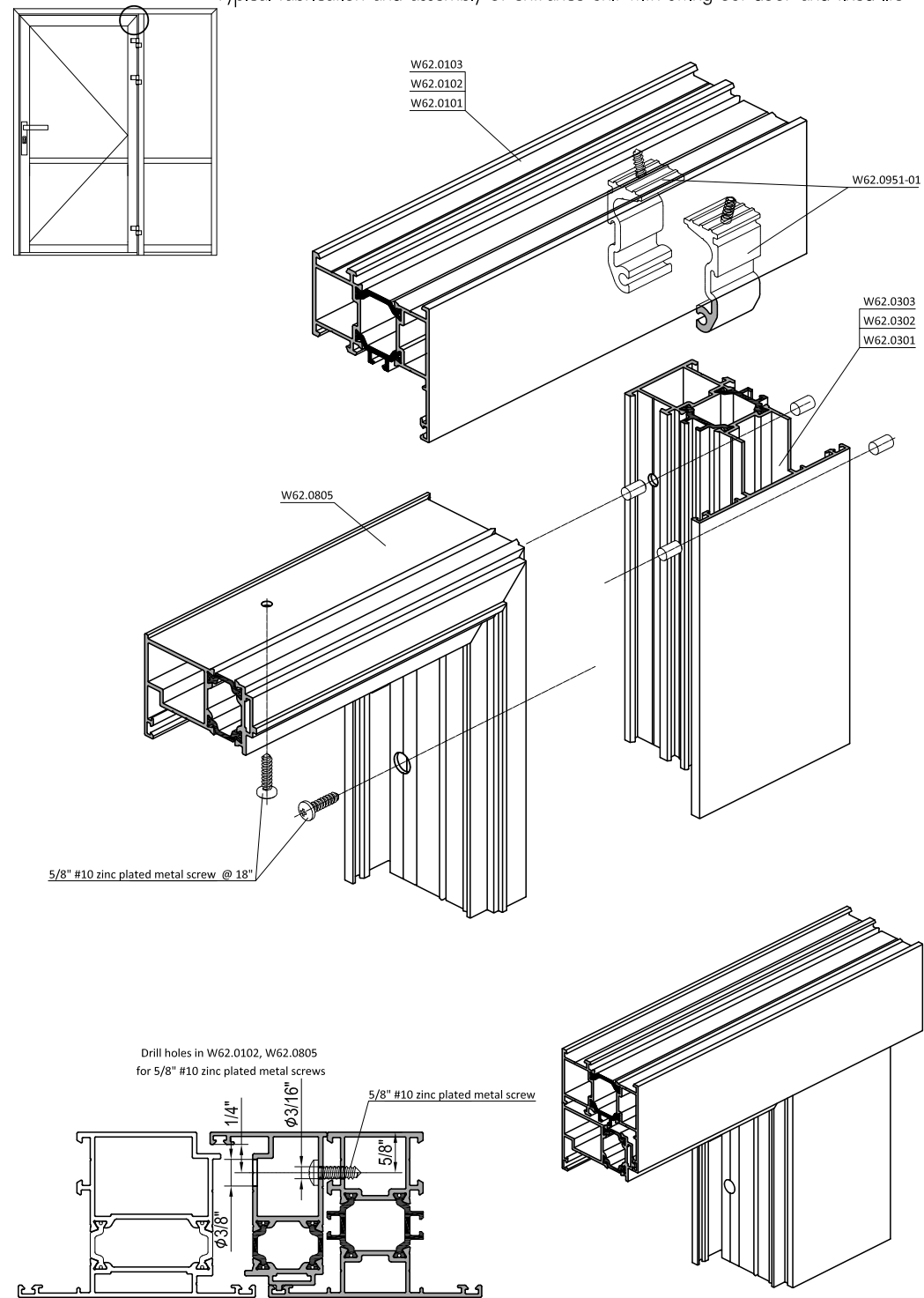

Typical fabrication and assembly of entrance unit with swing out door and transom

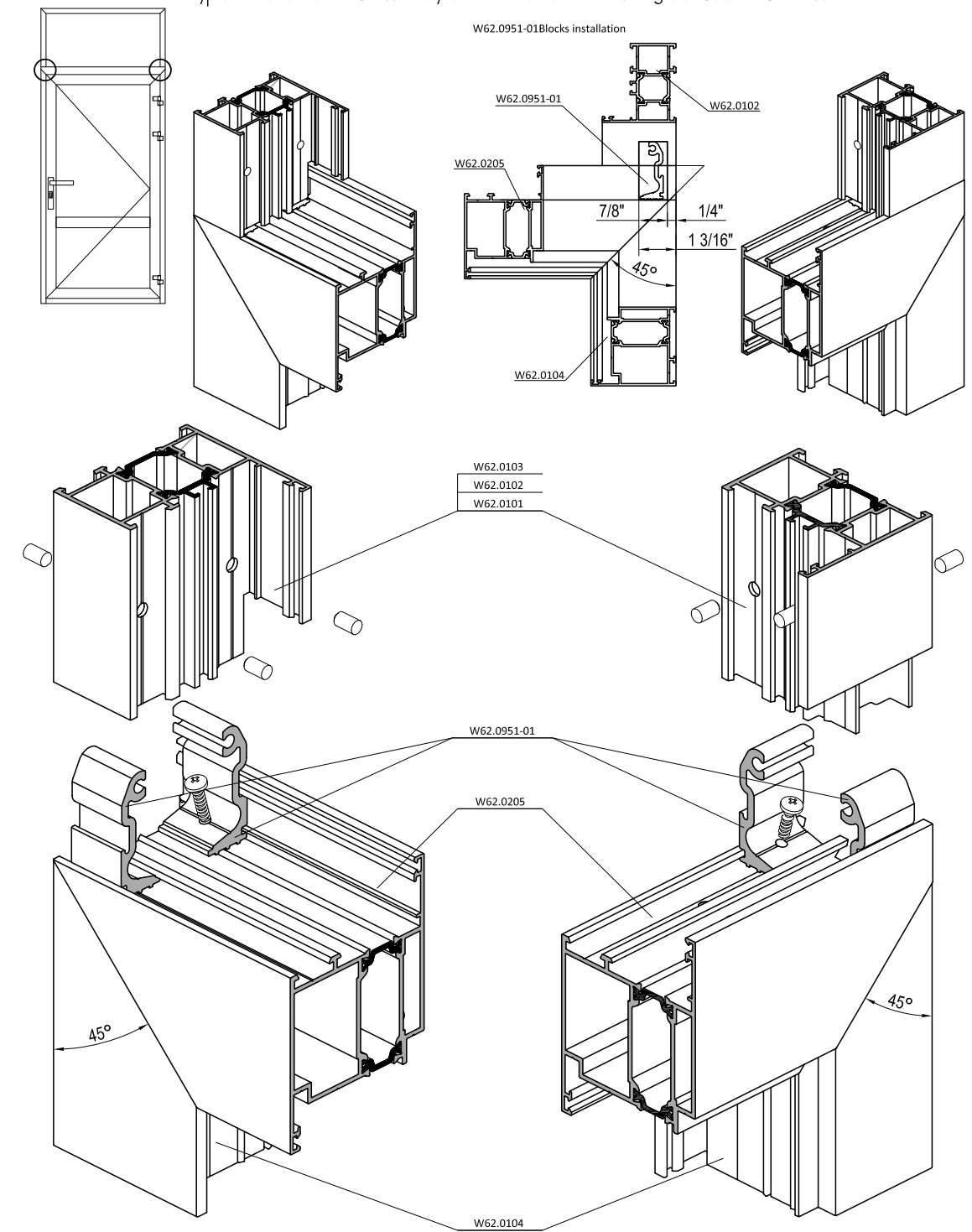

Typical fabrication and assembly of double window with adaptor molding

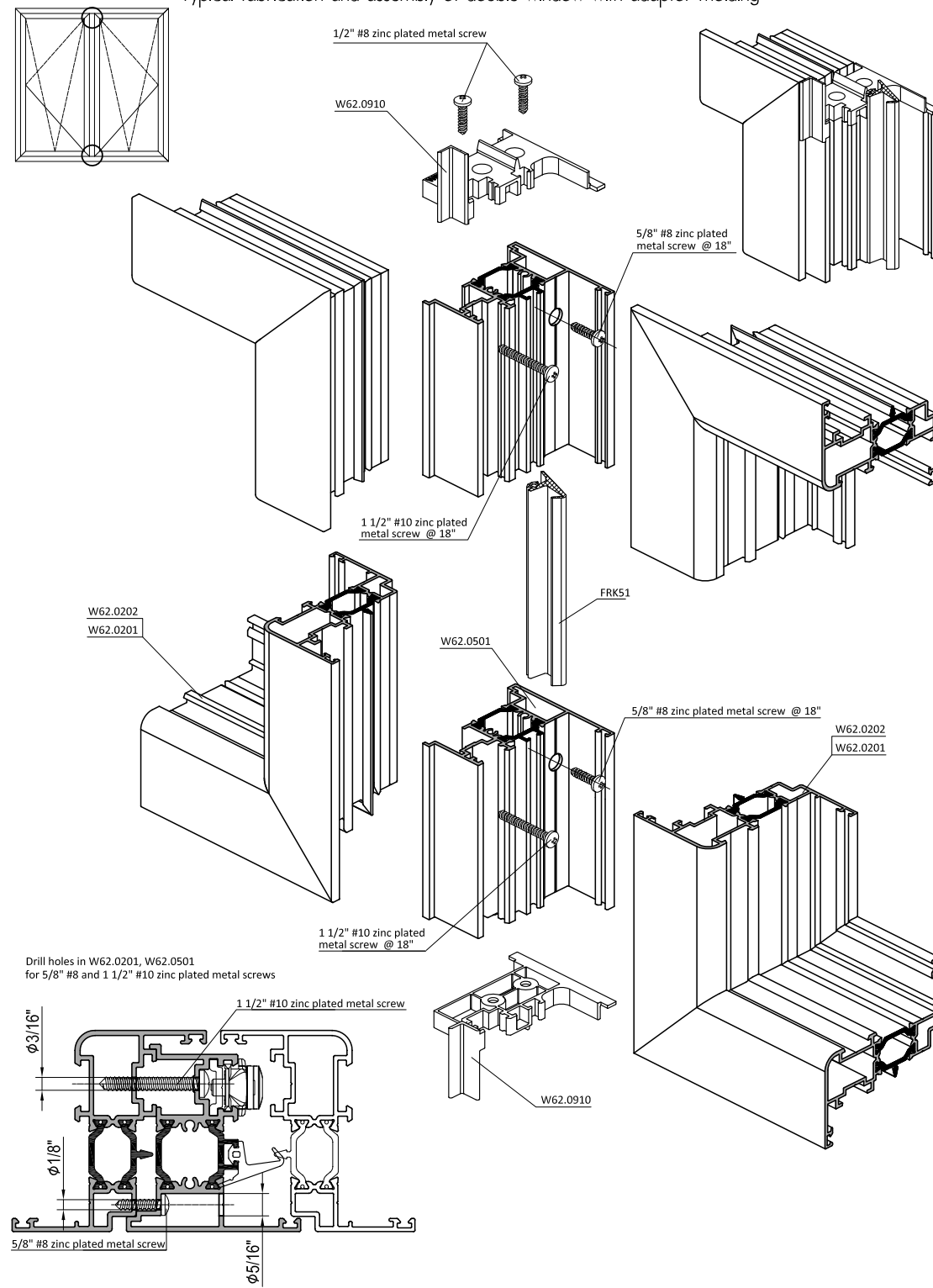

Divider block installation

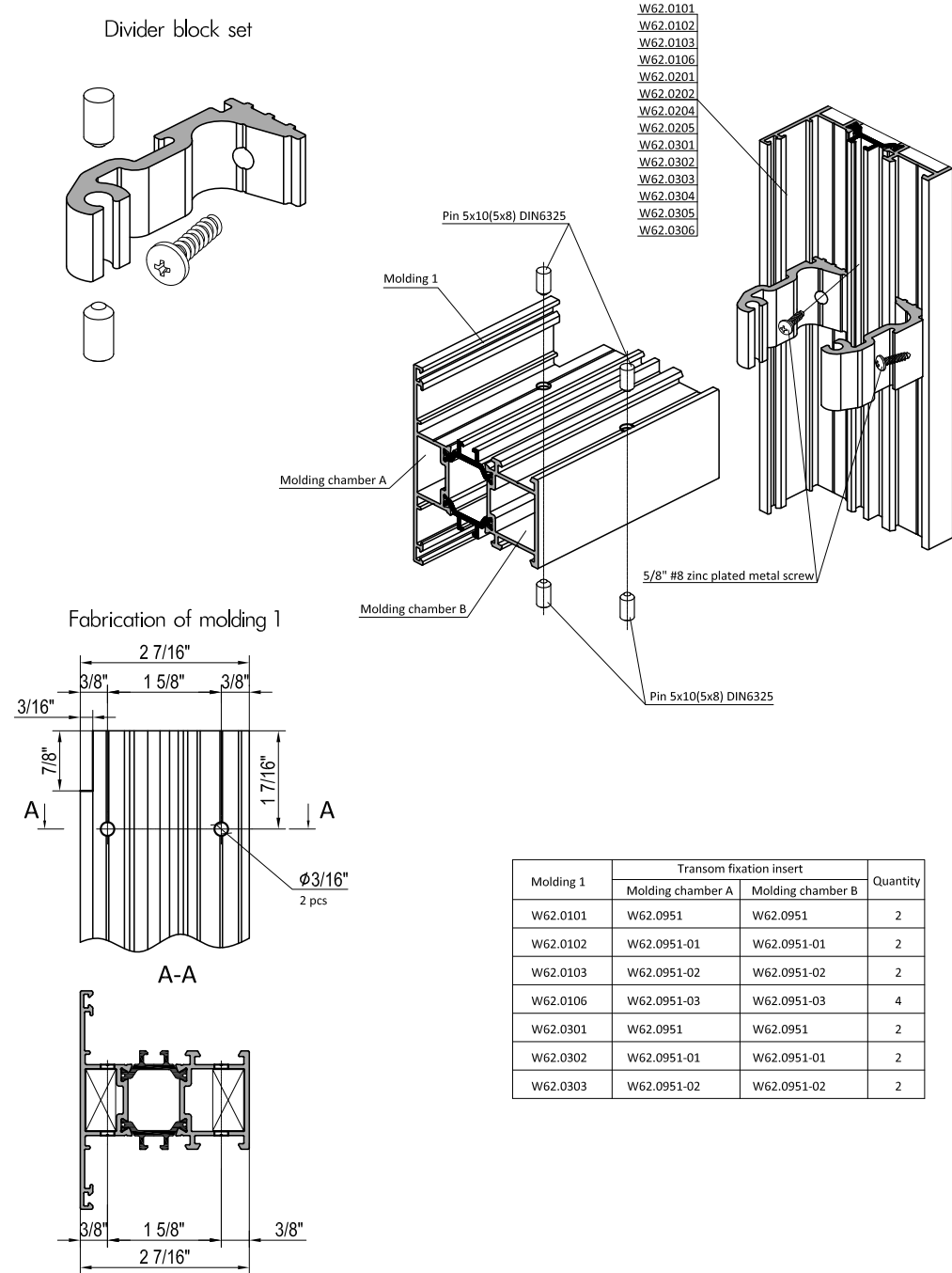

⚠ Note: for W62.0101 and W62.0301 use 5x8 DIN6325 pin

Water deflector installation on swing out door

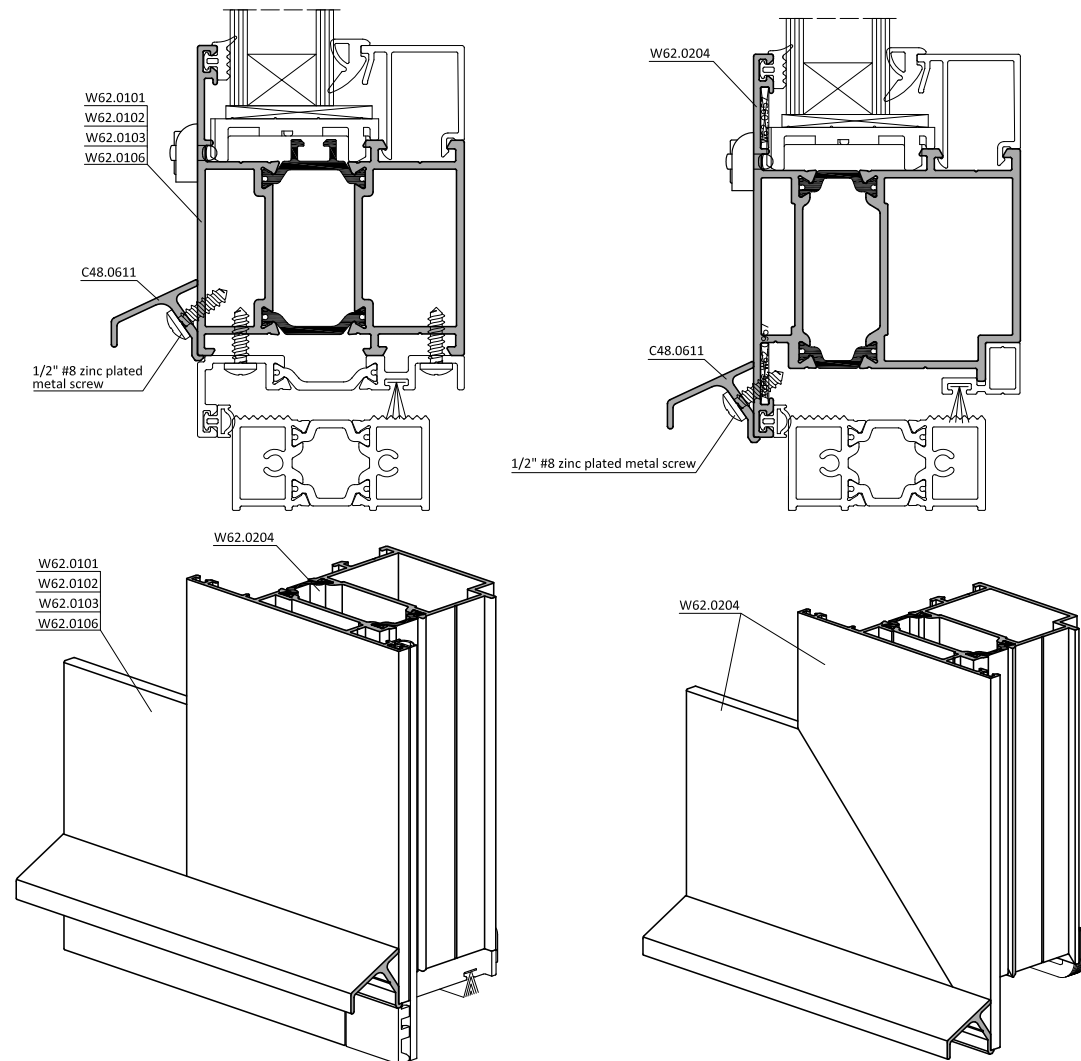

Water deflector installation on swing in door

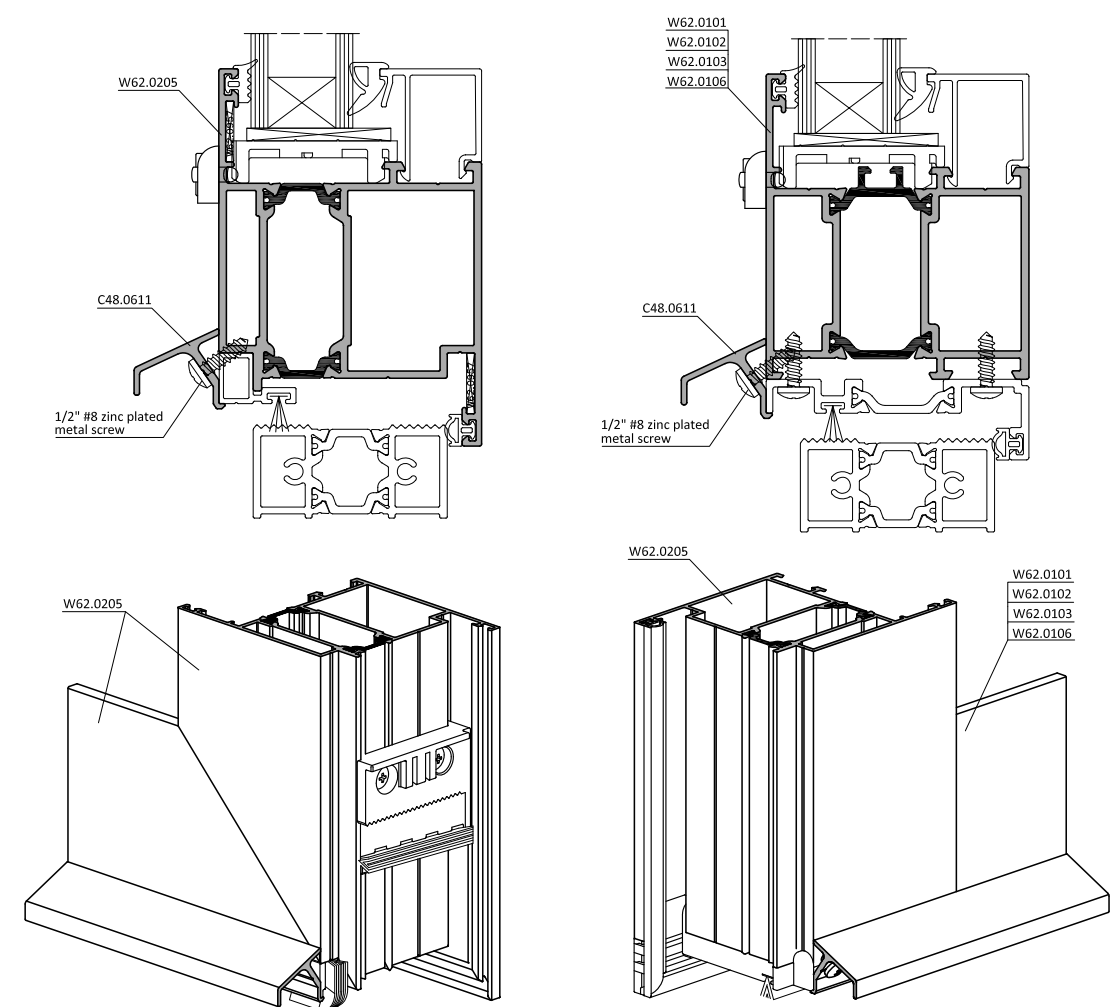

Water deflector C48.0611 fabrication for W62.0204

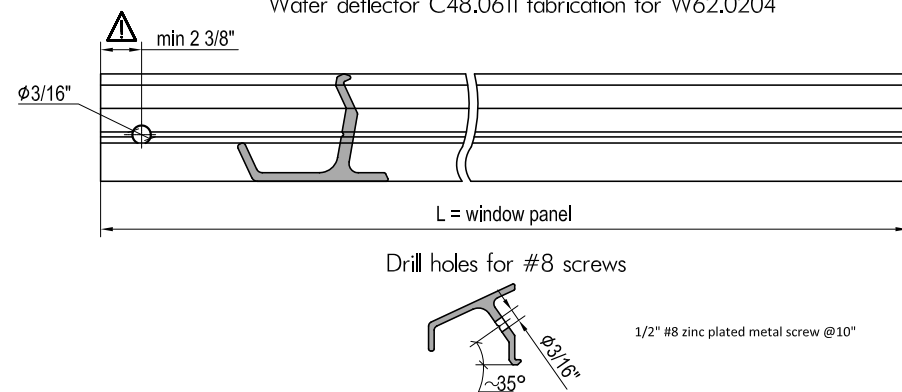

Water deflector C48.0611 fabrication for W62.0205

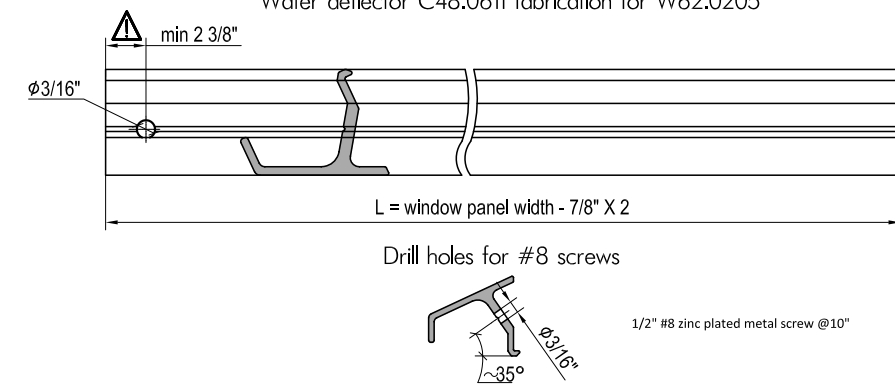

Water deflector installation on passive door

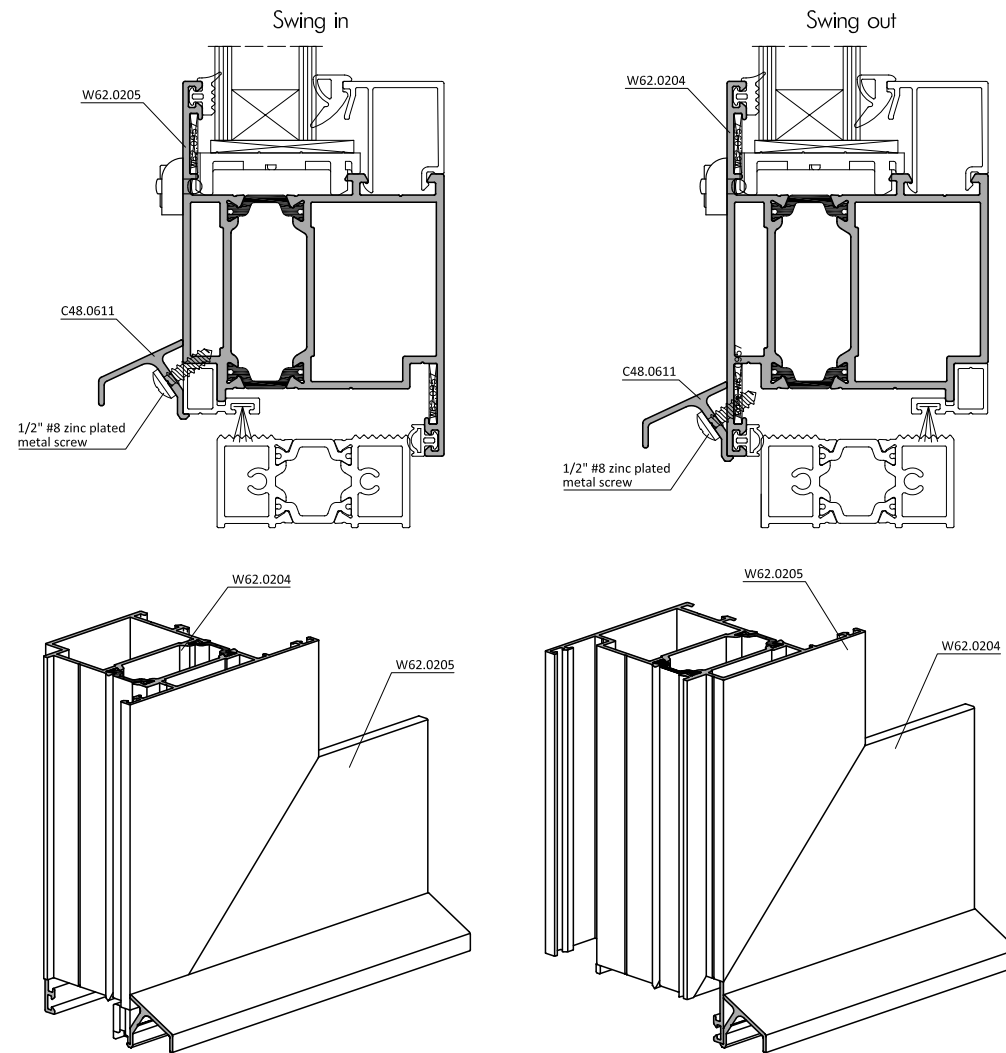

Water deflector installation

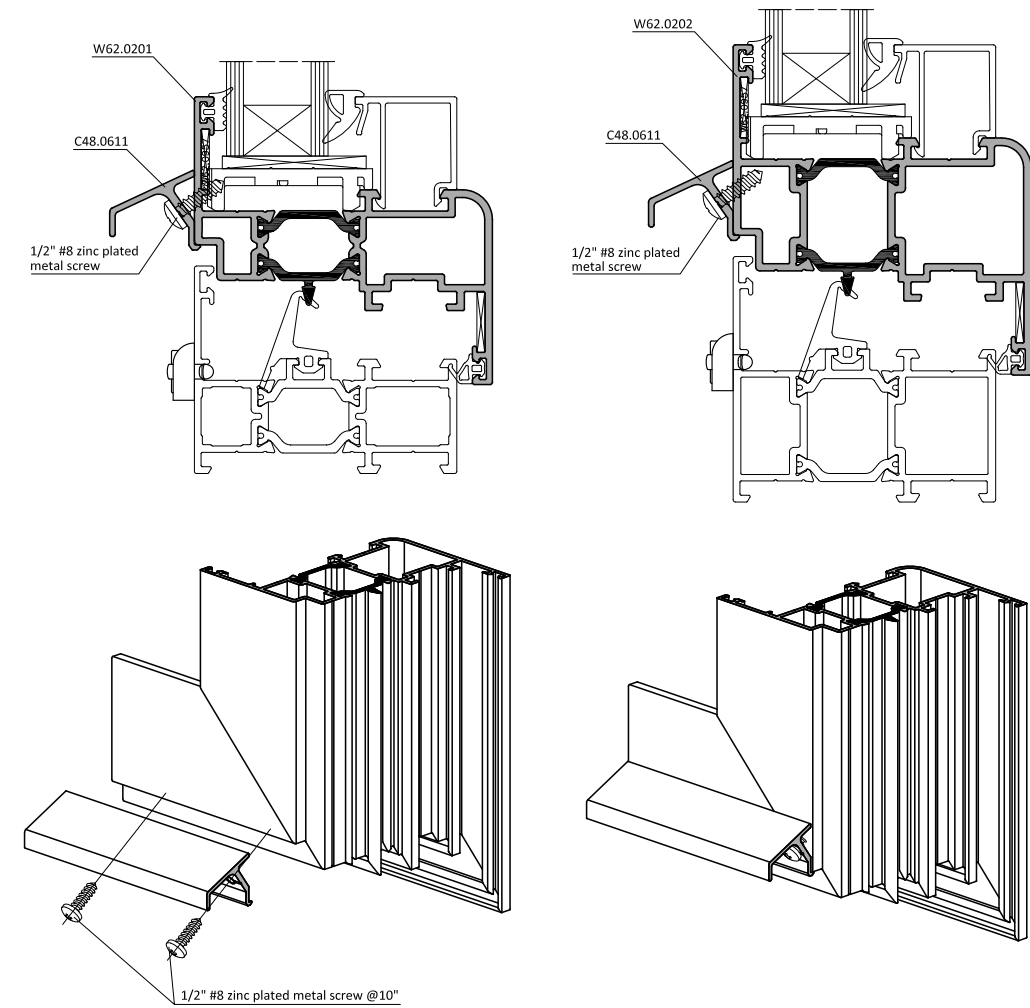

Water deflector C48.0611 fabrication for W62.0205

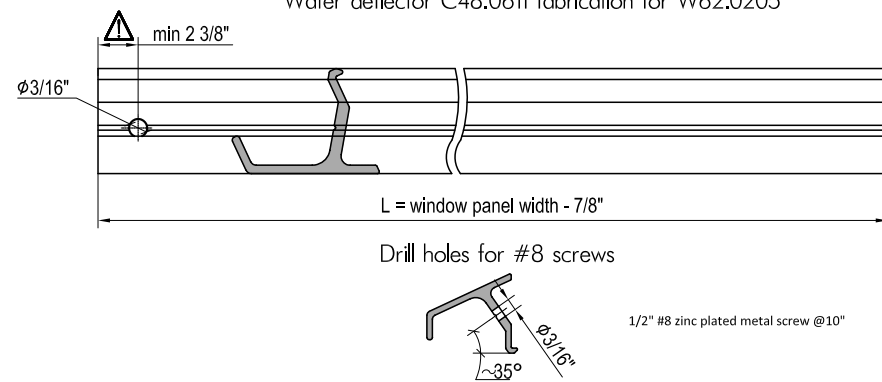

Water deflector C48.0611 fabrication for W62.0201

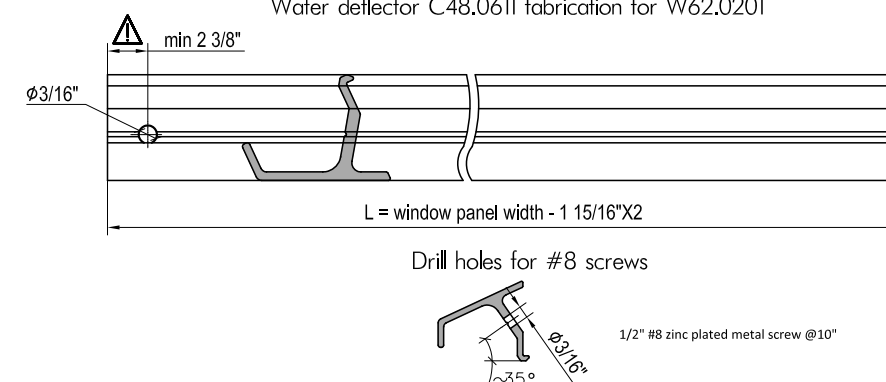

W62.0201, W62.0202, W62.0203 fabrication for optional hardware installation

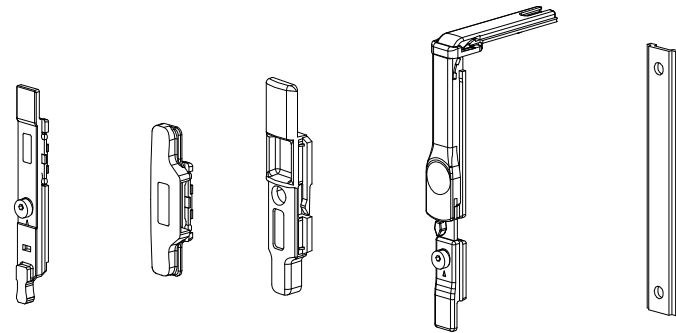

Notches for hardware

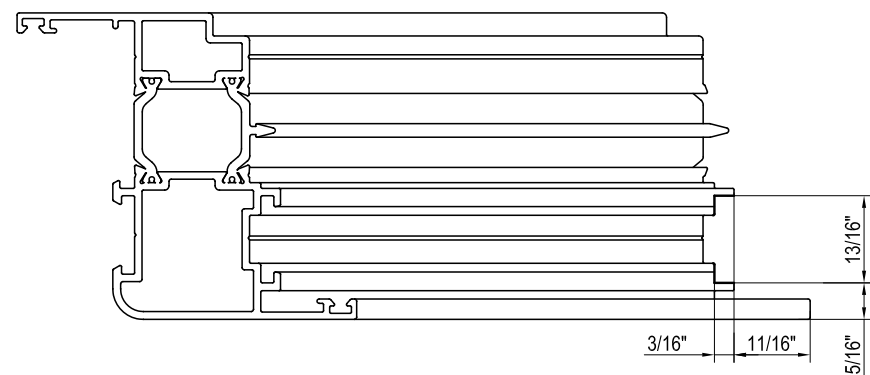
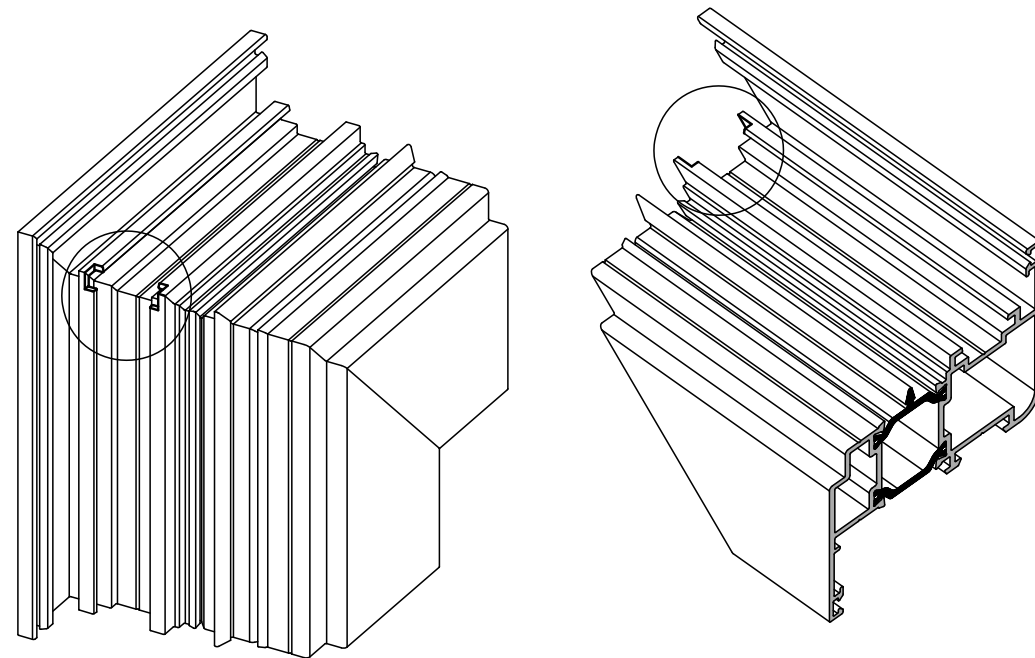

Vent and drain holes location

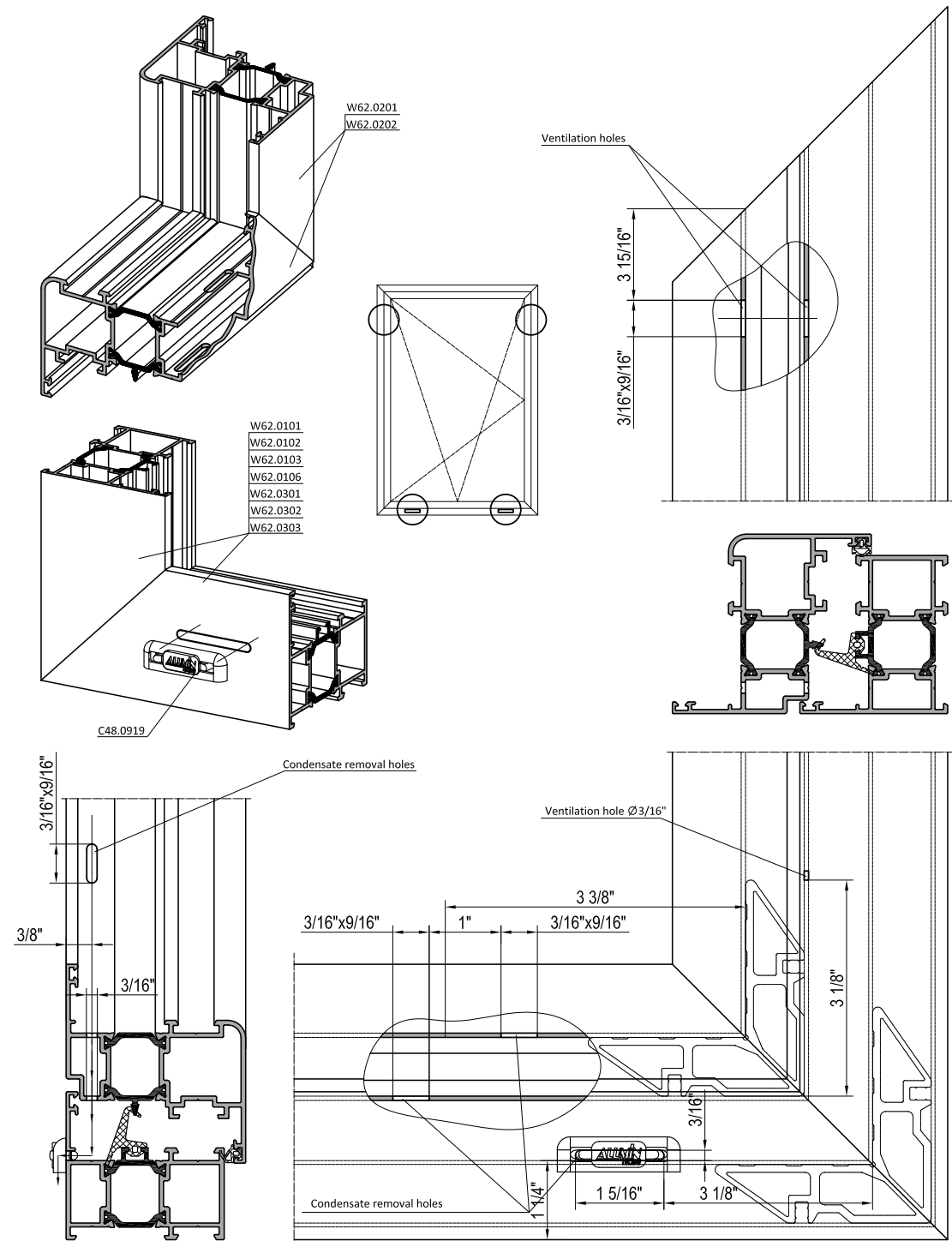

Vent and drain holes location

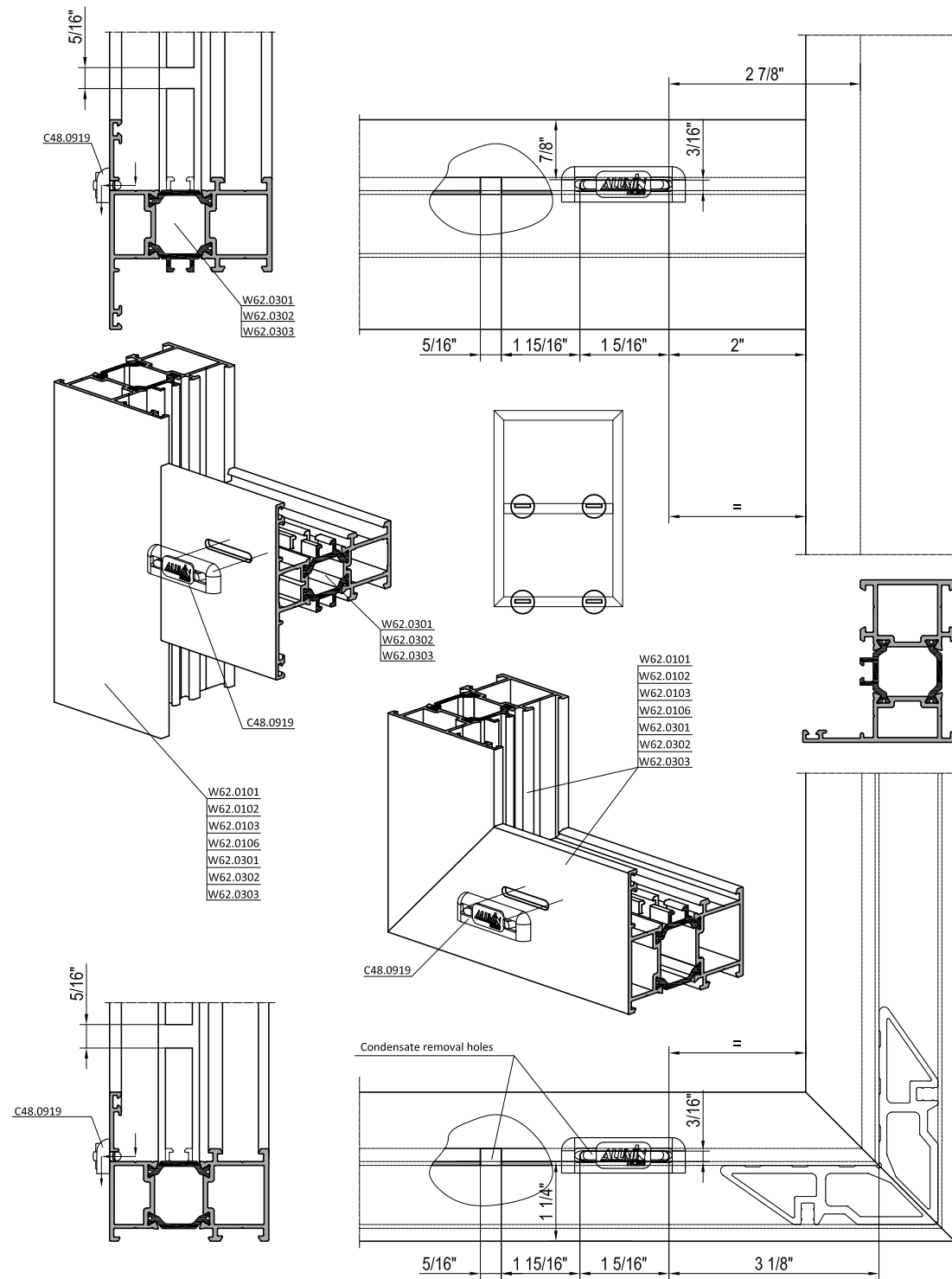

Vent and drain holes location

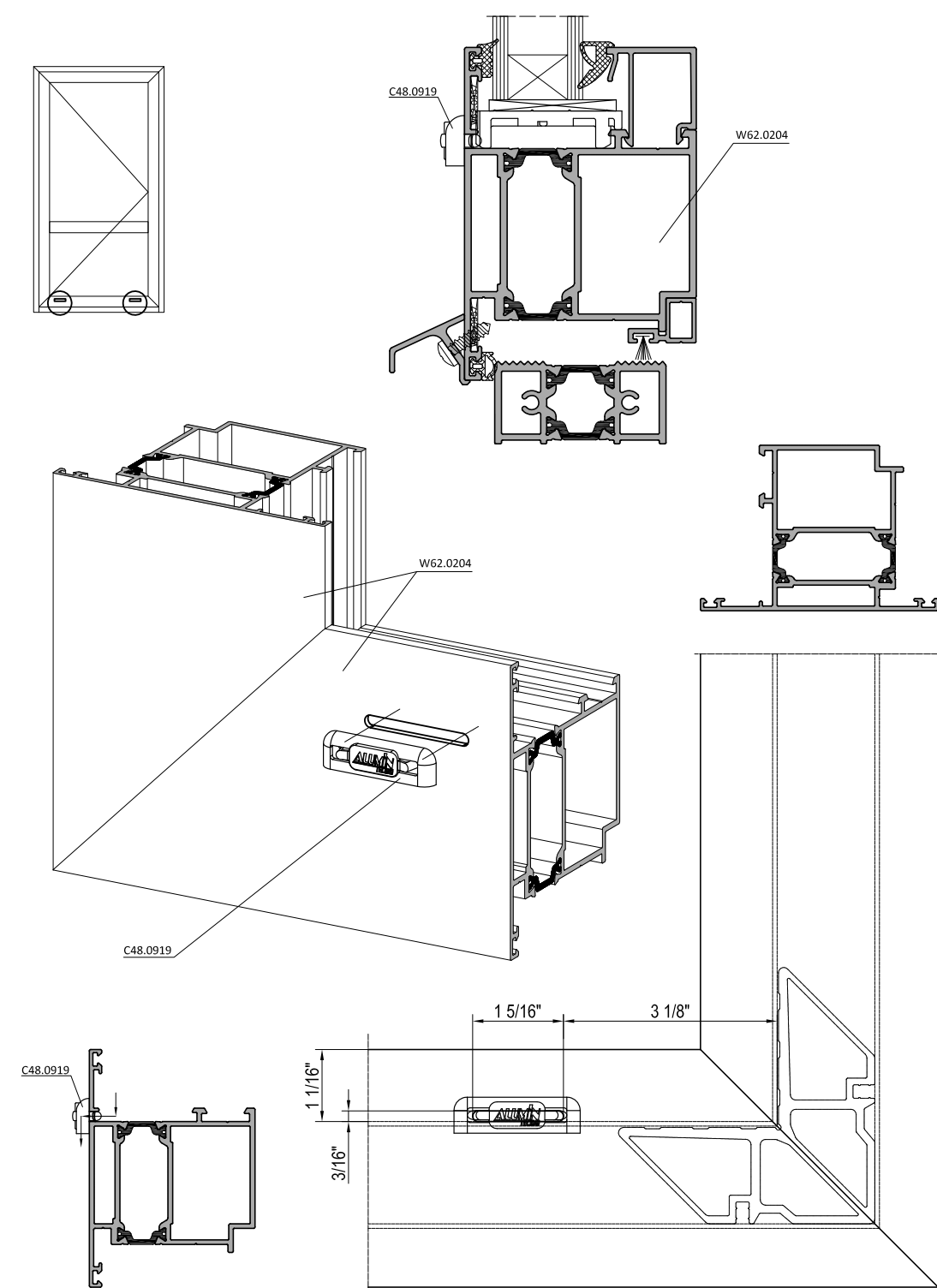

Vent and drain holes location

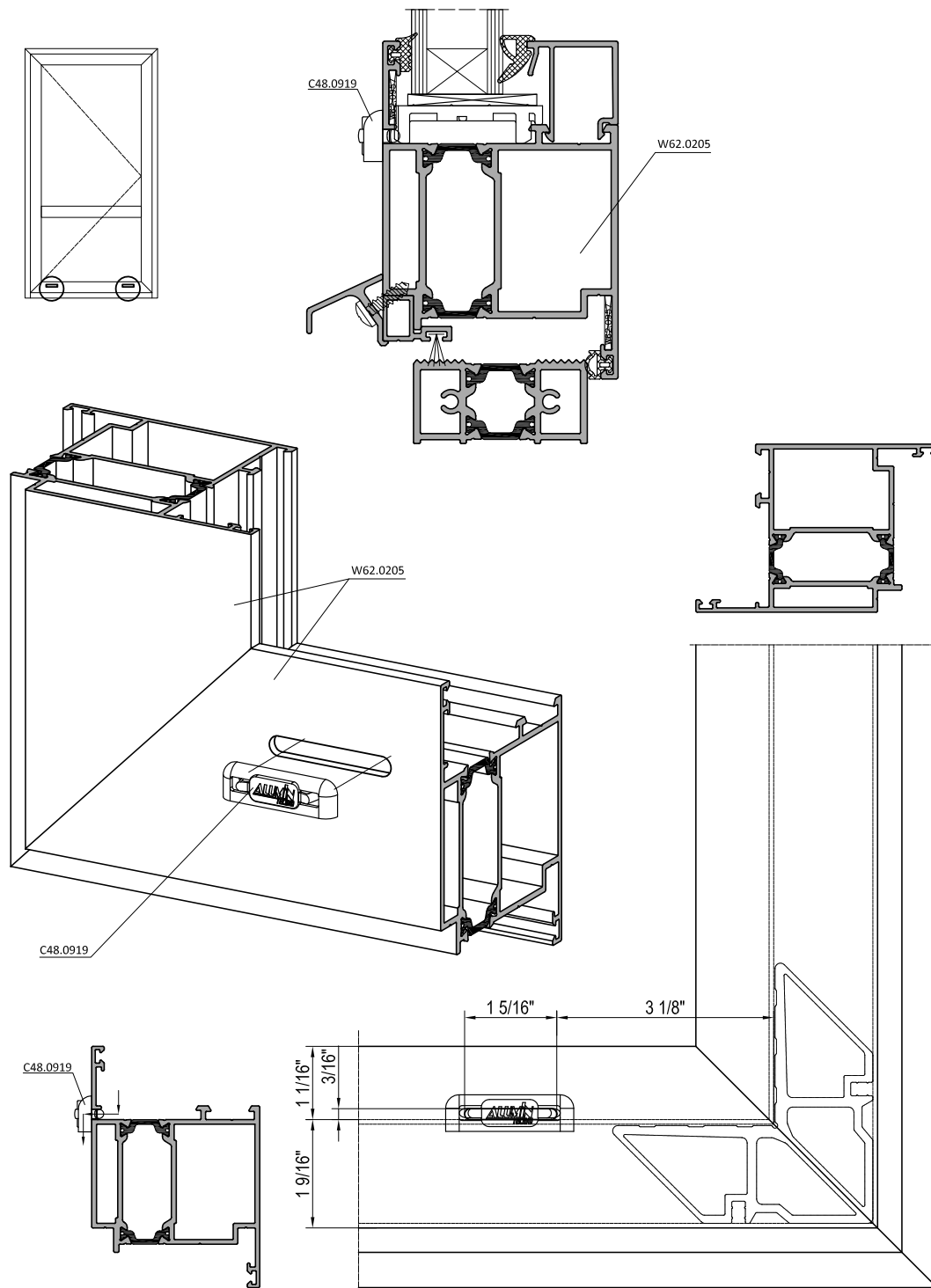

85° - 240° corner assembly

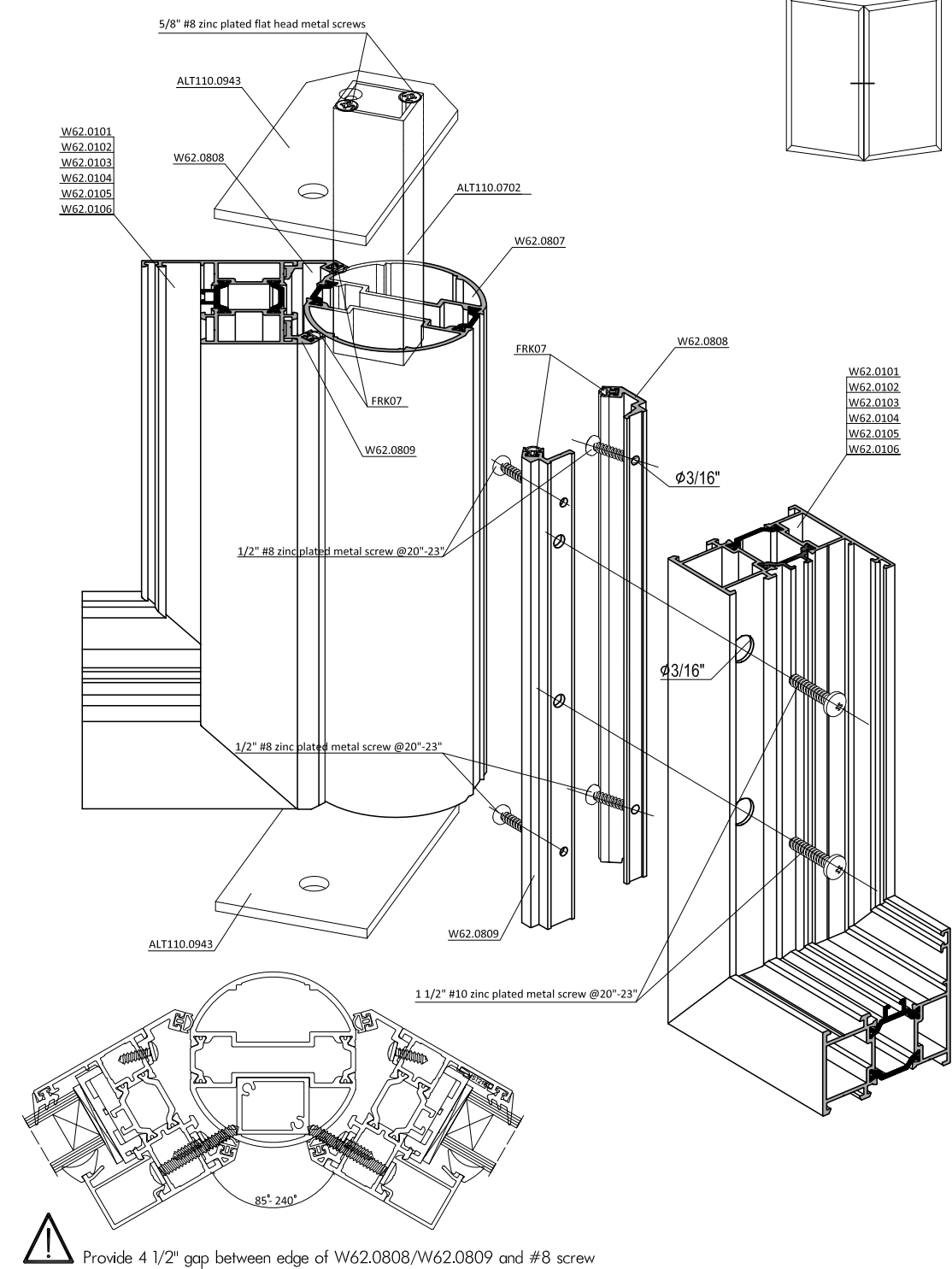

⚠ Provide 4 1/2" gap between edge of W62.0808/W62.0809 and #8 screw

90° corner assembly

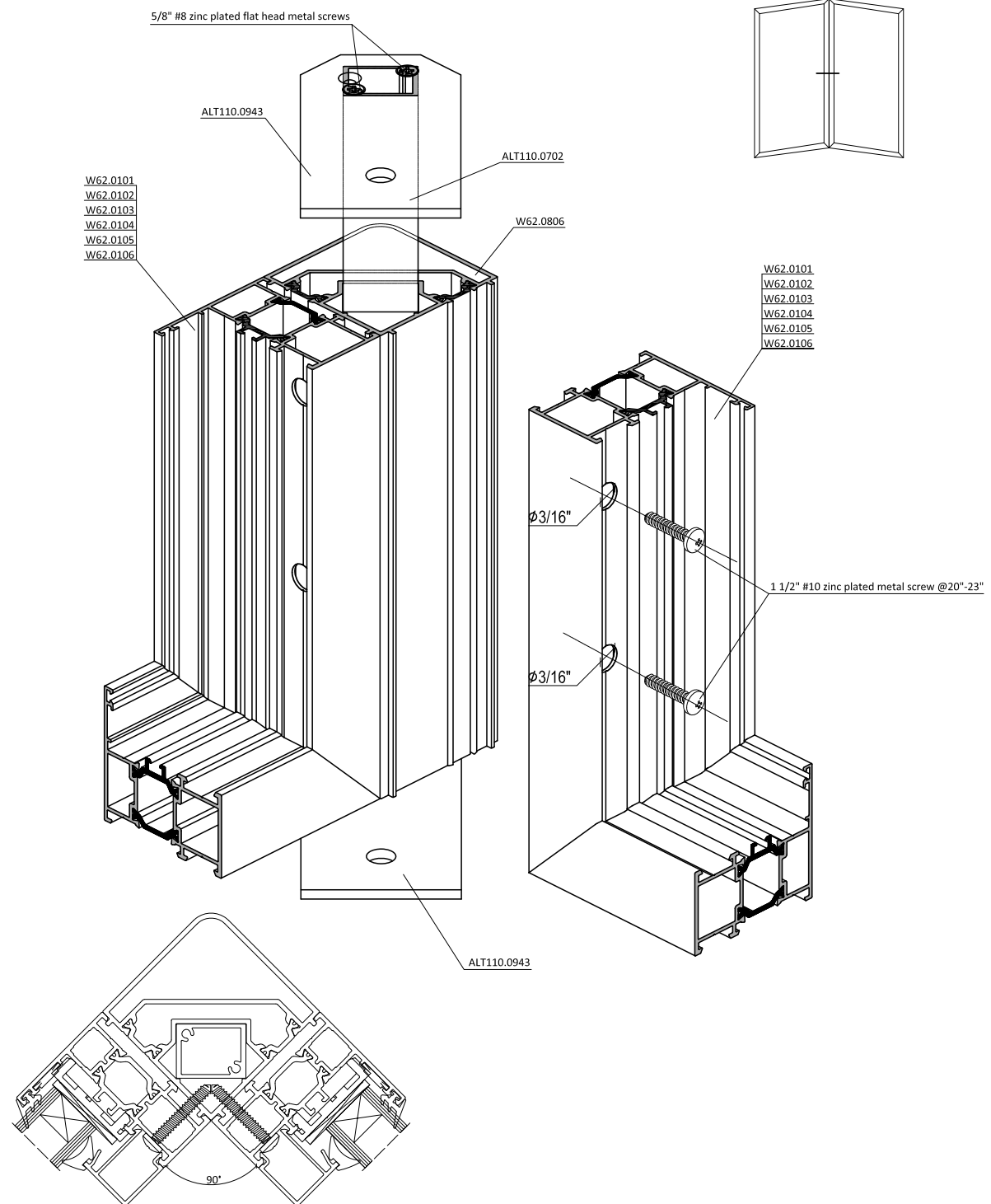

Insulated connection

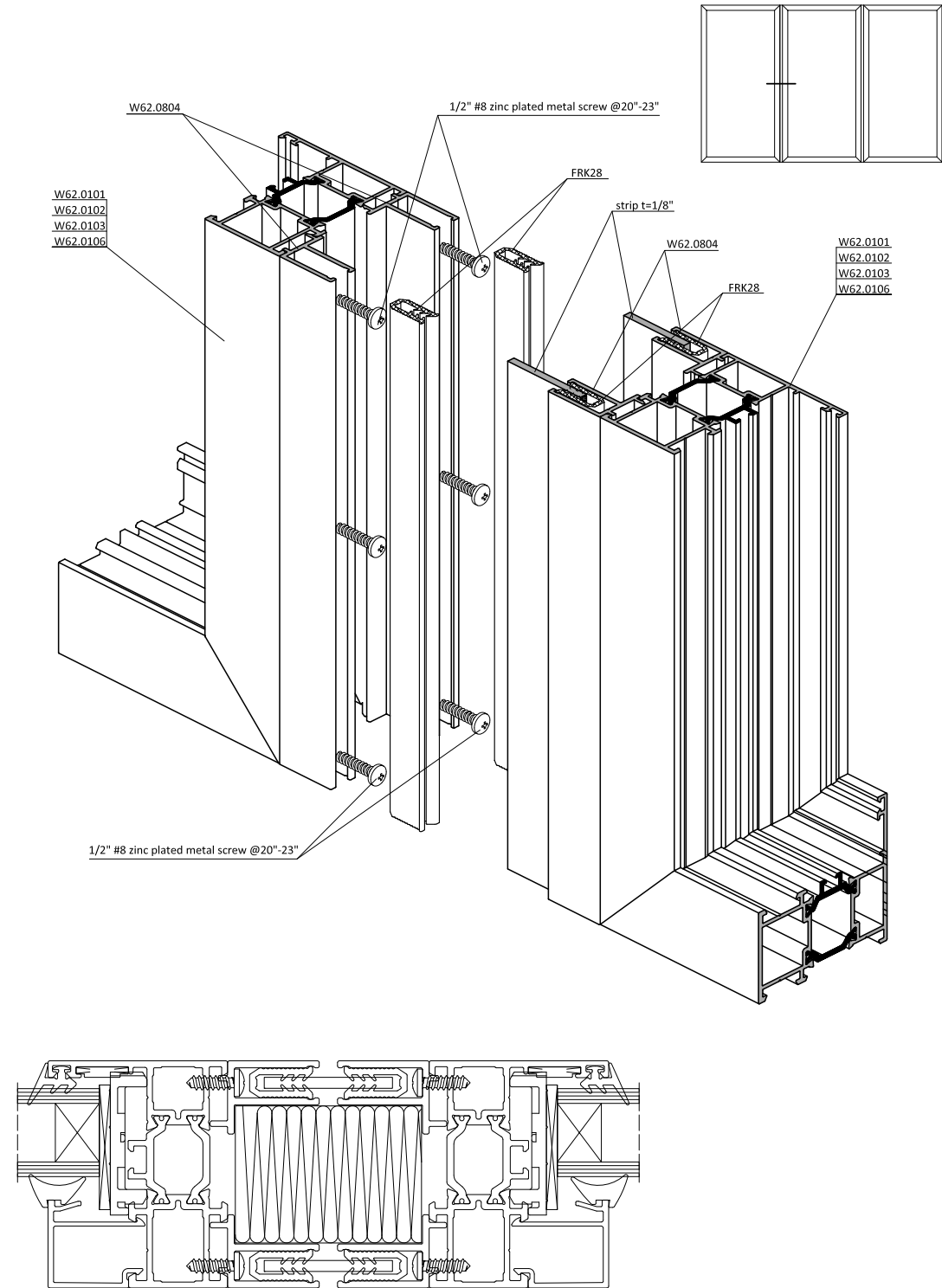

Saddle W62.0801 installation with door frame molding W62.0104

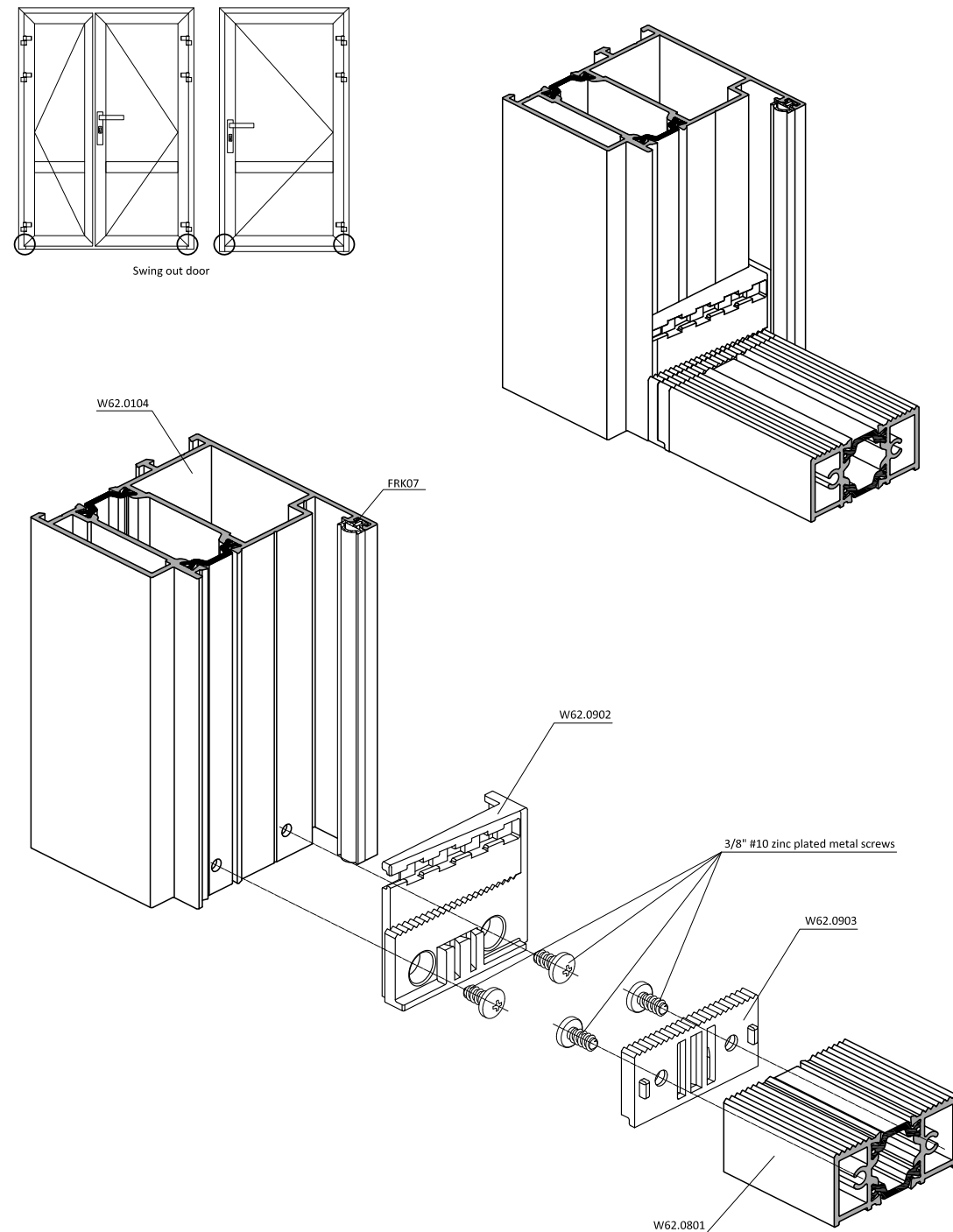

Saddle installation W62.0802 with door frame molding W62.0104

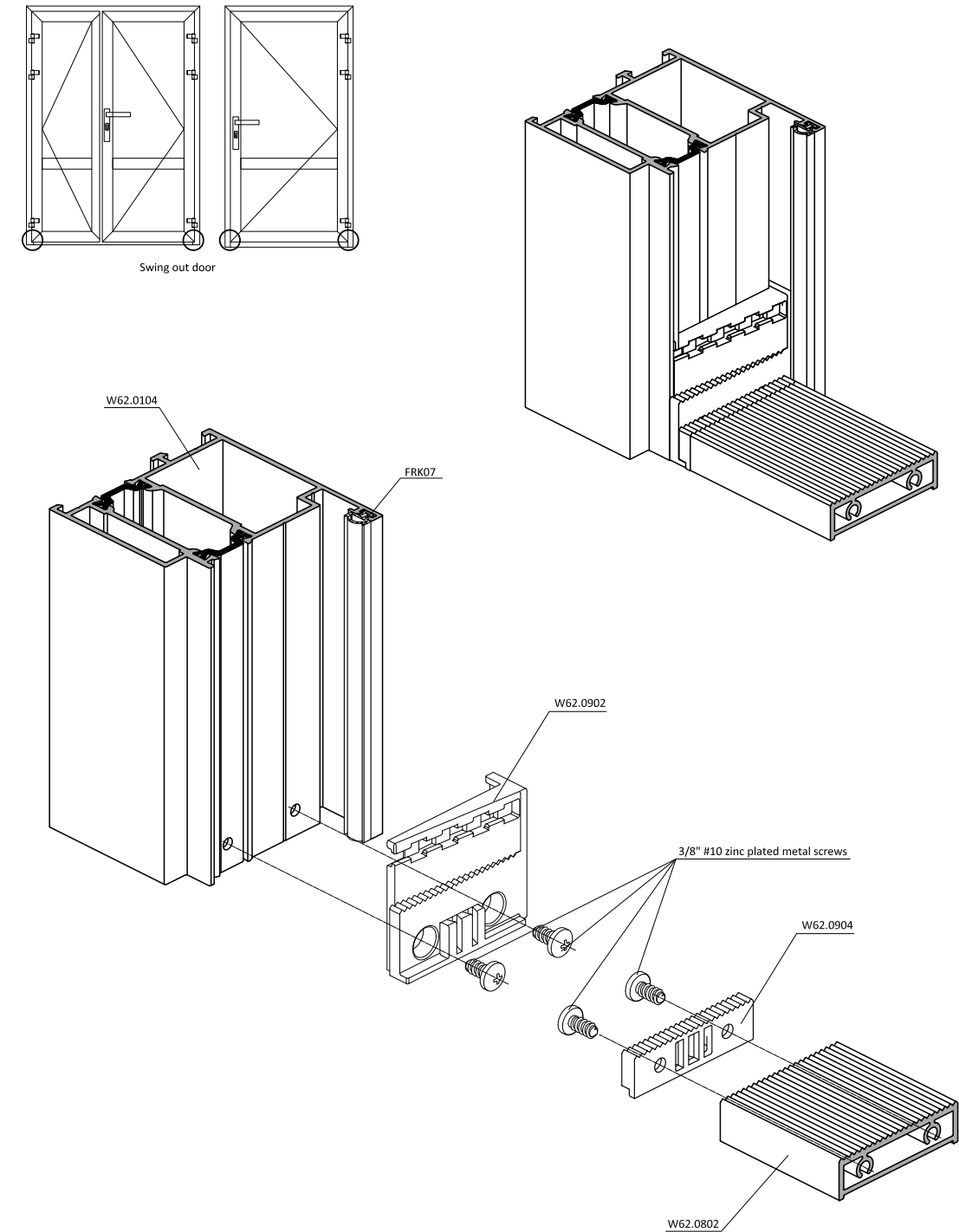

Saddle W62.0801 installation with door frame molding W62.0105

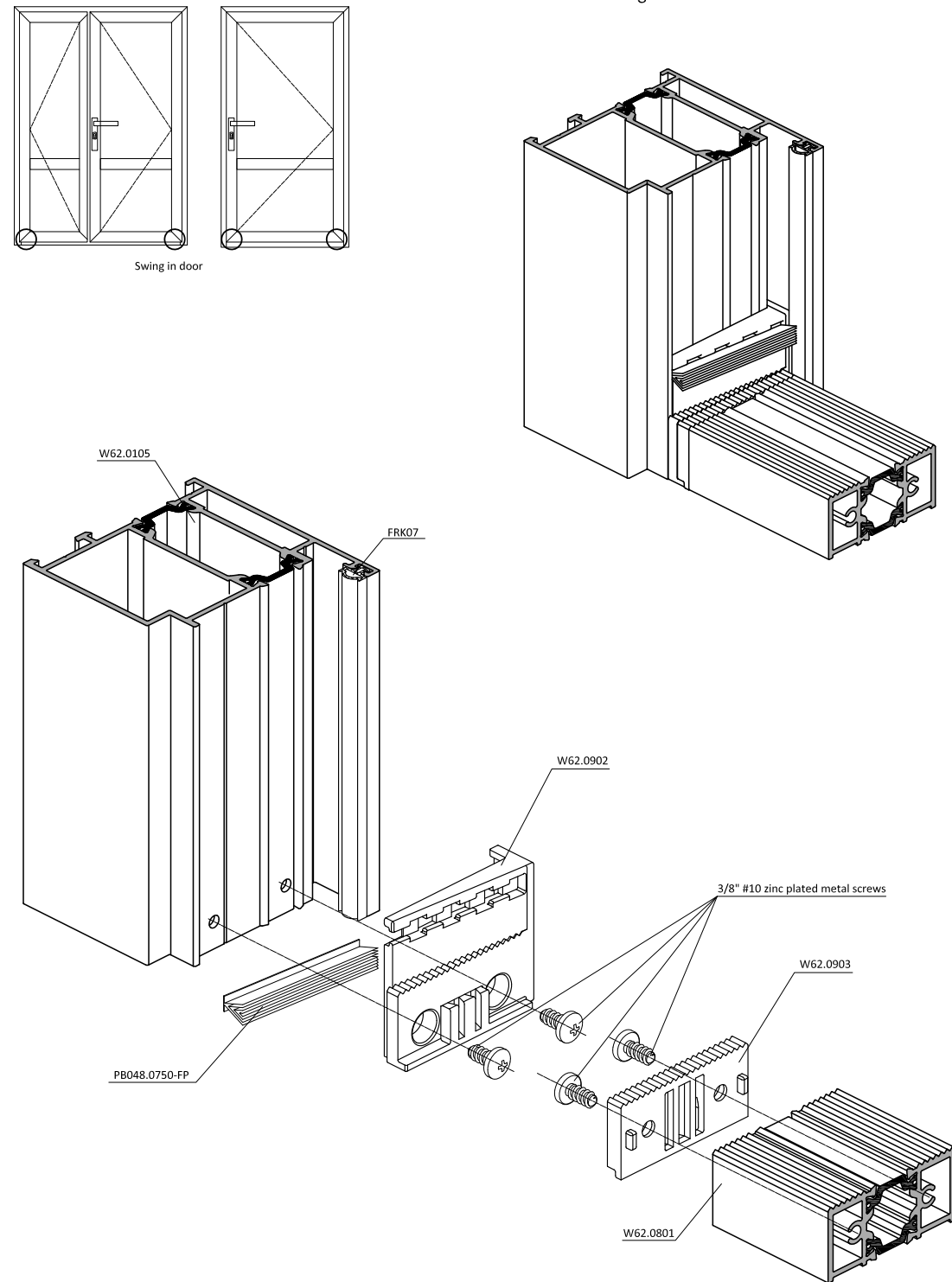

Saddle W62.0802 installation with door frame molding W62.0105

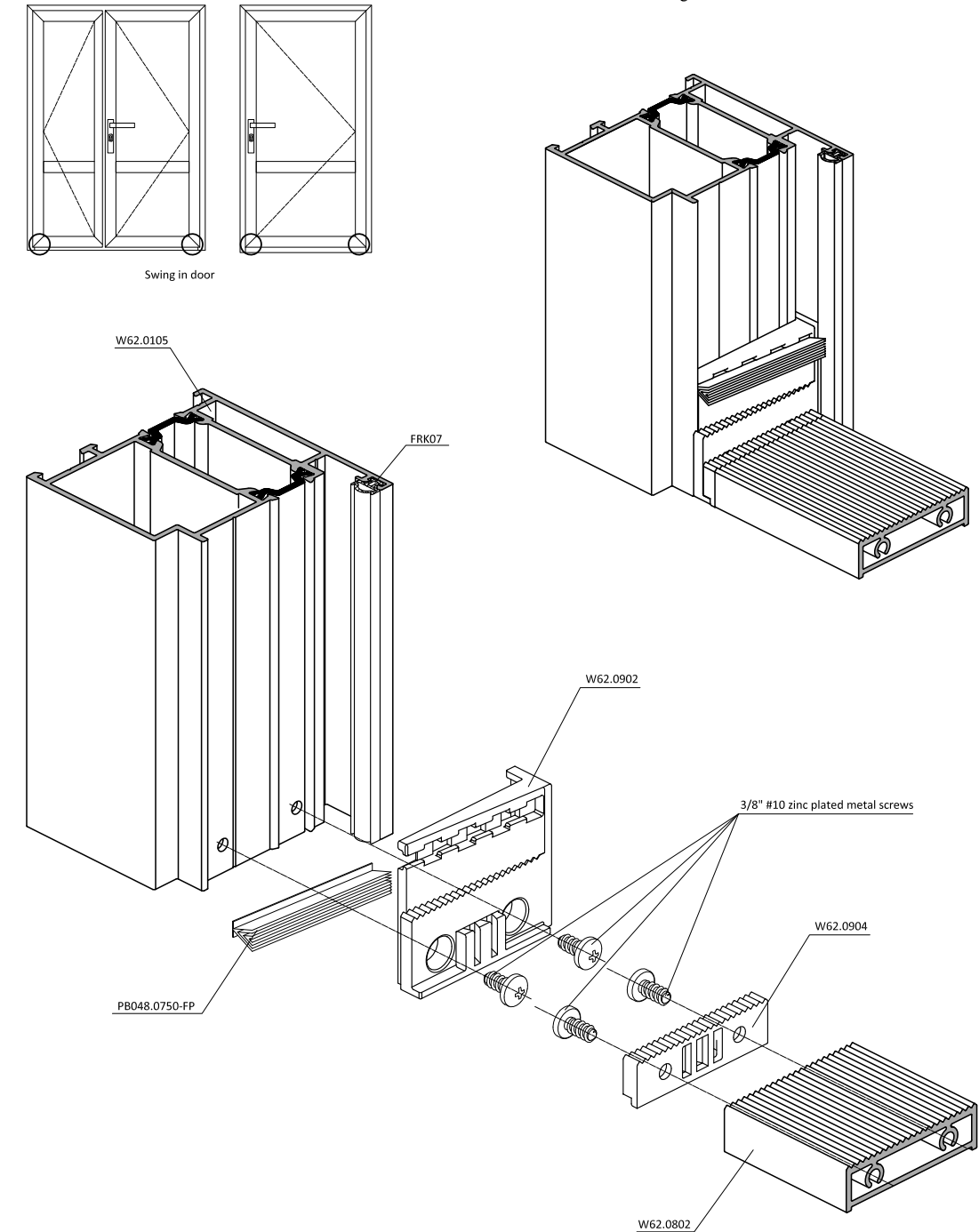

Saddle installation with moldings W62.0102 (0103) in combination with W62.0805

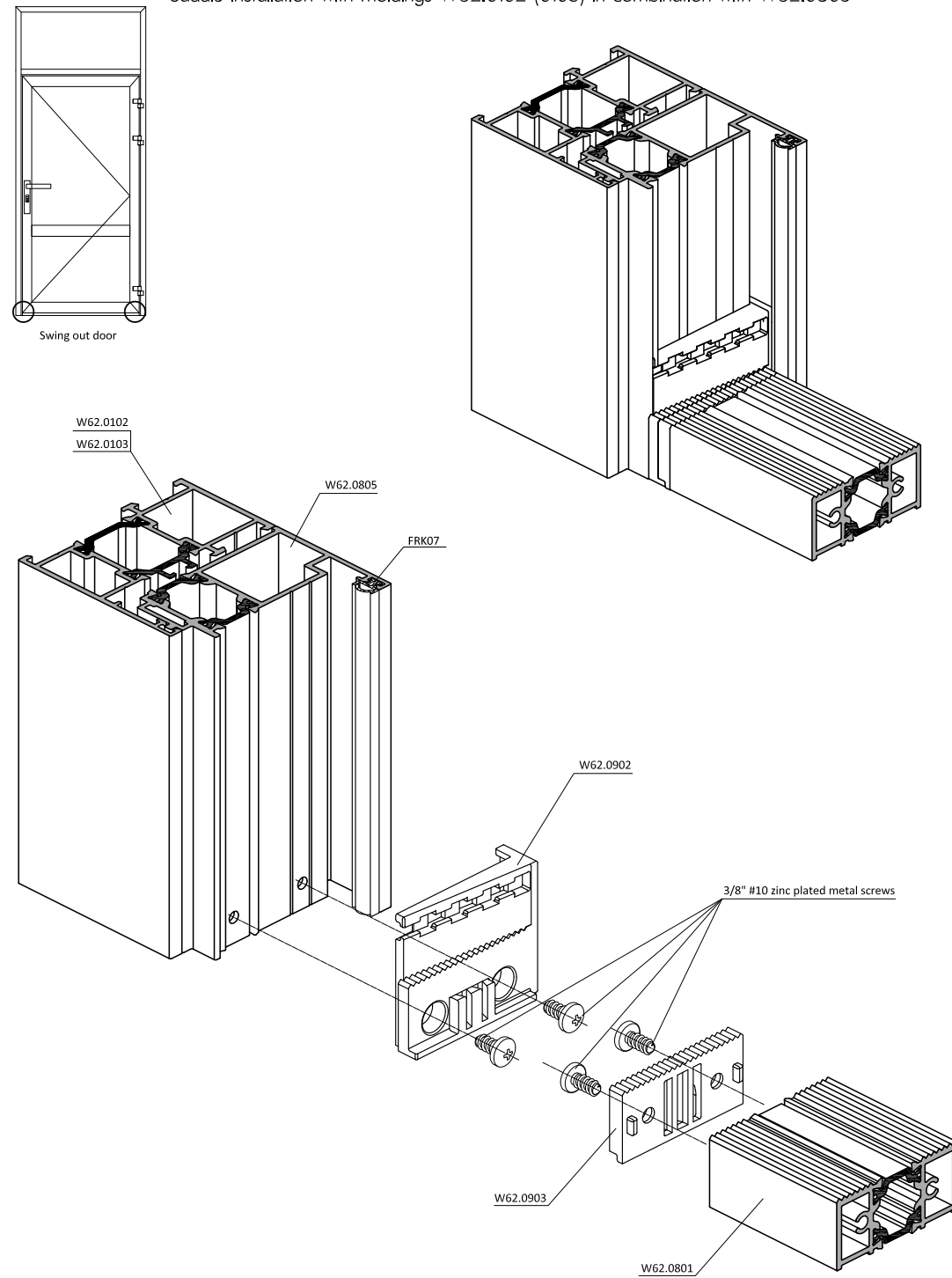

Saddle installation with moldings W62.0102 (0103) in combination with W62.0805

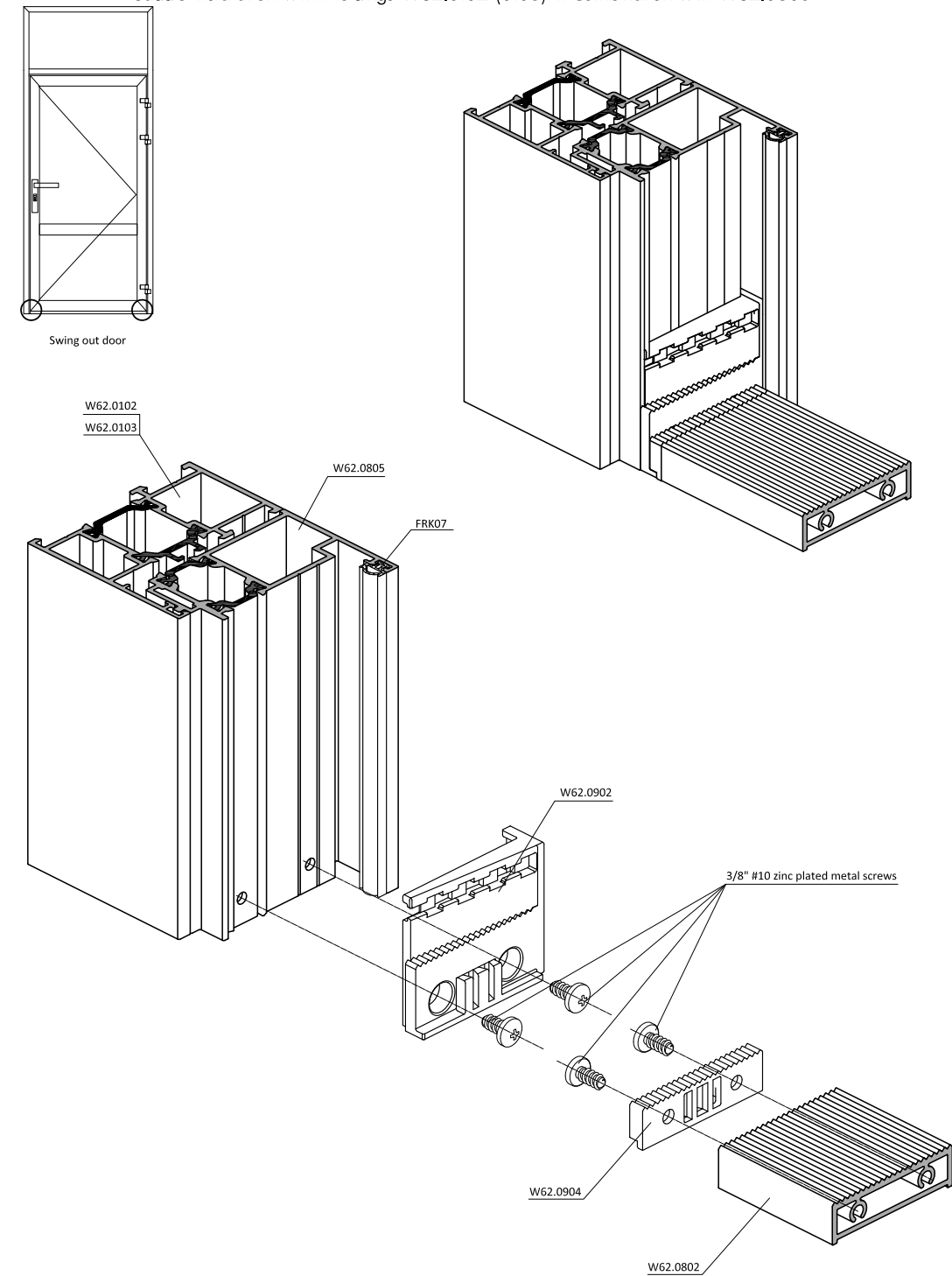

RECOMMENDED HARDWARE

Window handle NEFER 0760B

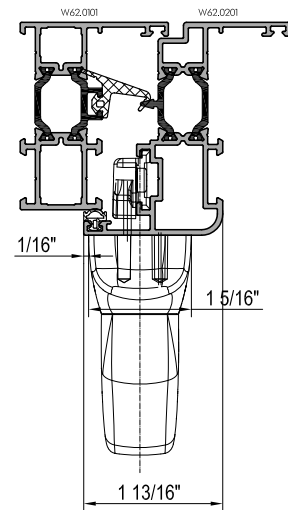

Window hinge BLITZ 9730

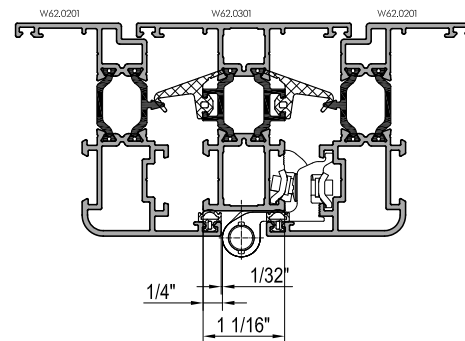

Window hinge VENICE 5601

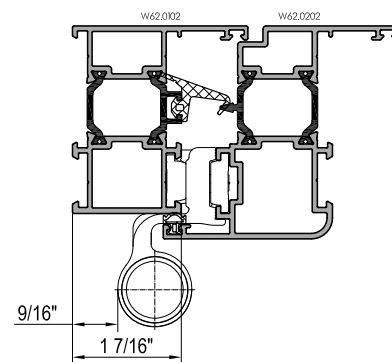

Outside opening

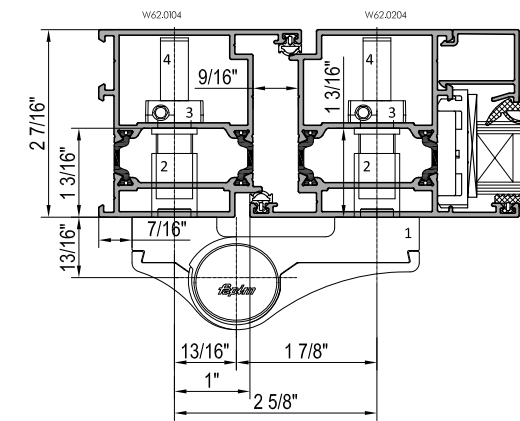

- 1 - hinge LOIRA+ 7010i or 7013i with 2 5/8" center-to-center spacing
- 2 - set of non adjustable collars 6664294
- 3 - set of insert plates 6620AI
- 4 - screws M8x60 from the set 6664294

Outside opening

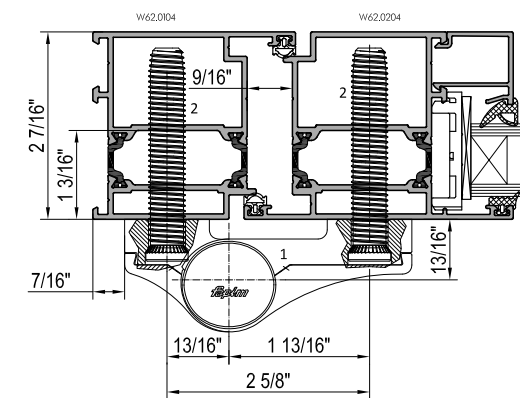

- 1 - hinge LOIRA+ 7010Vi or 7013Vi with 2 5/8" center-to-center spacing
- 2 - self-tapping screw 2 3/8" 6604i

Inside opening

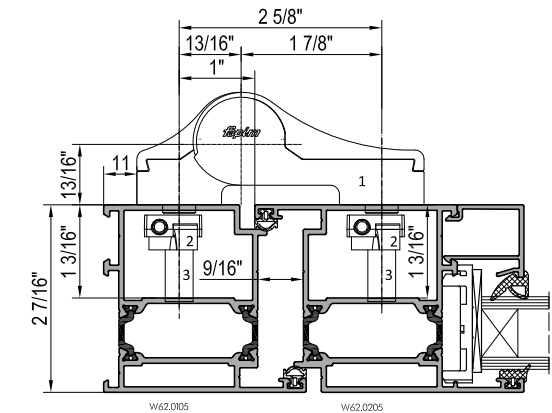

- 1 - hinge LOIRA+ 7010Vi or 7013Vi with 2 5/8" center-to-center spacing
- 2 - self-tapping screw 2 3/8" 6604i

Outside opening

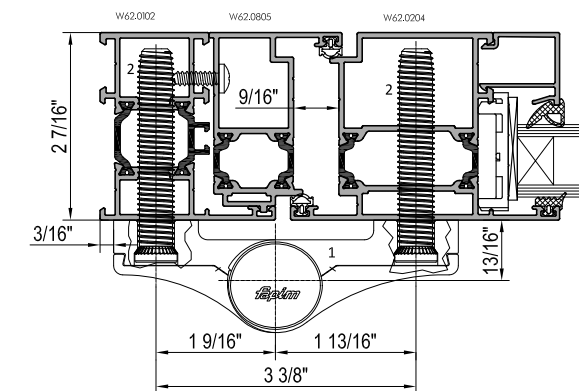

- 1 - hinge LOIRA+ 7040Vi or 7043V with 3 3/8" center-to-center spacing
- 2 - self-tapping screw 2 3/8" 6604i

Profiles fabrication for door hardware installation

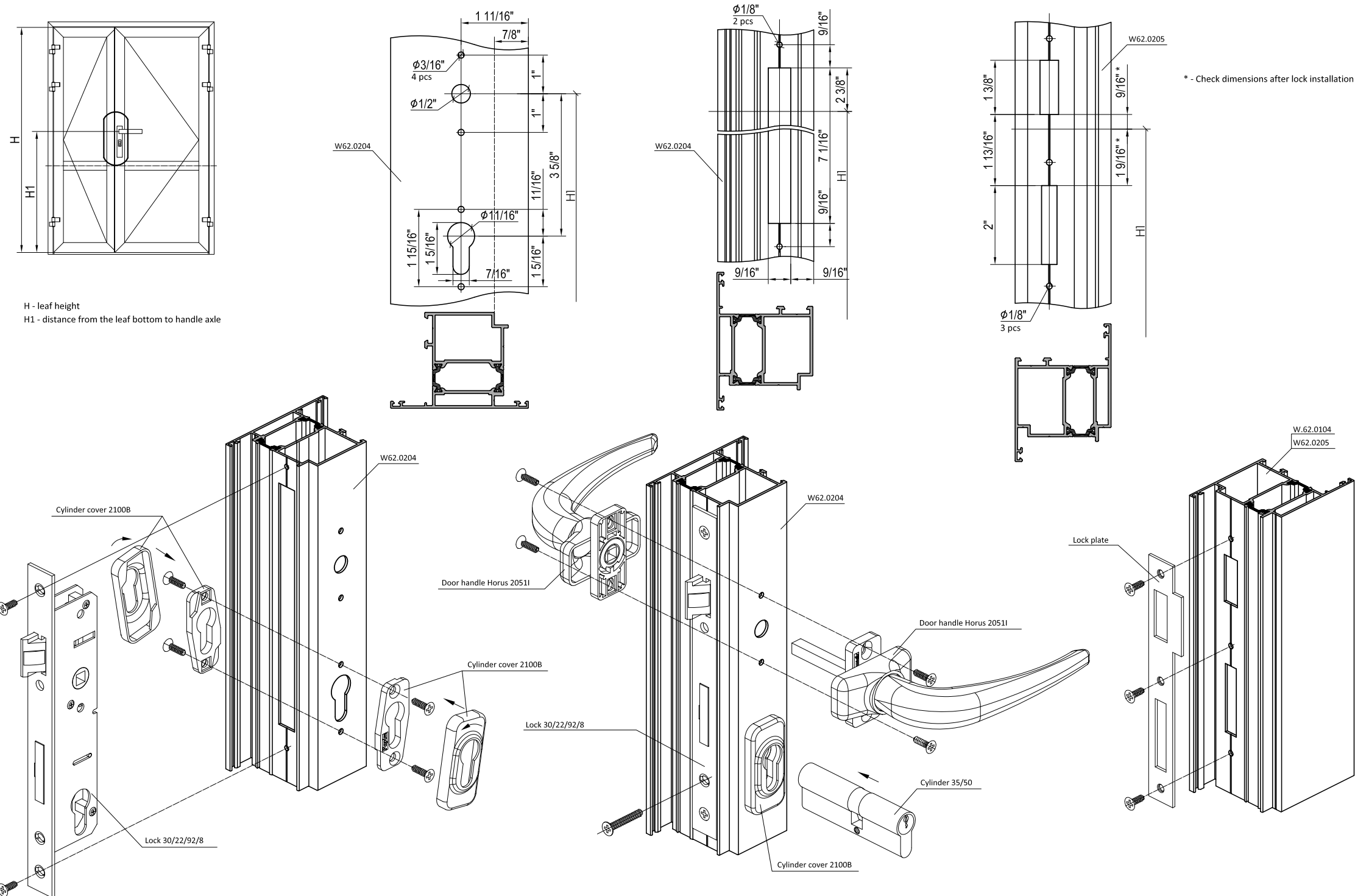

H - leaf height
H1 - distance from the leaf bottom to handle axle

* - Check dimensions after lock installation

⚠ Install cover plate 2100B prior to cylinder 35/50 installation

ART# 2051

ART# 0760B

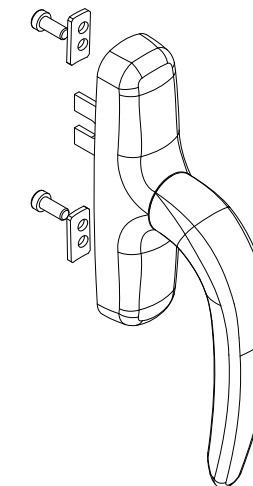
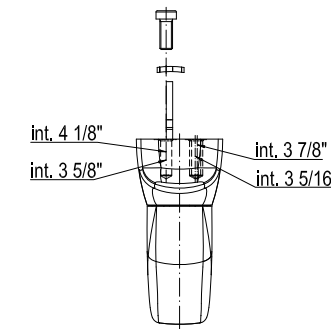
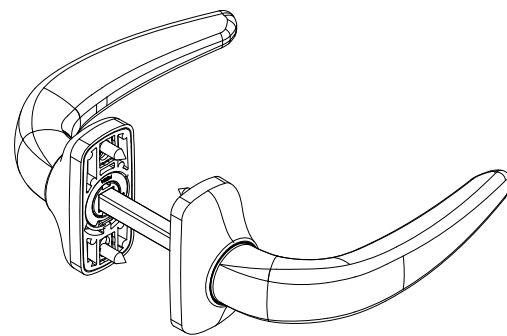
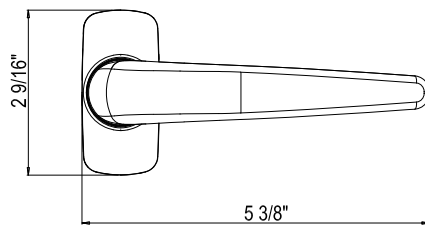
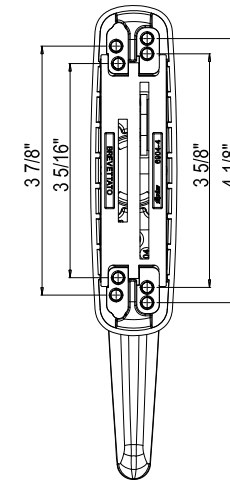
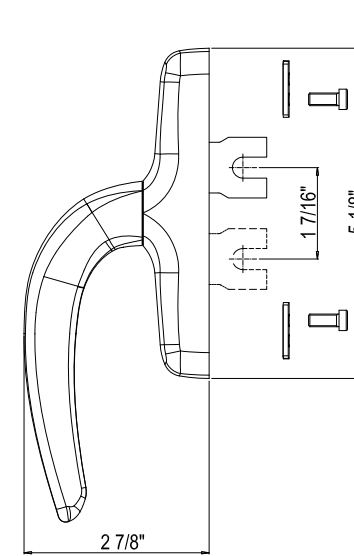
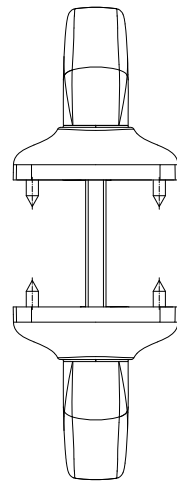
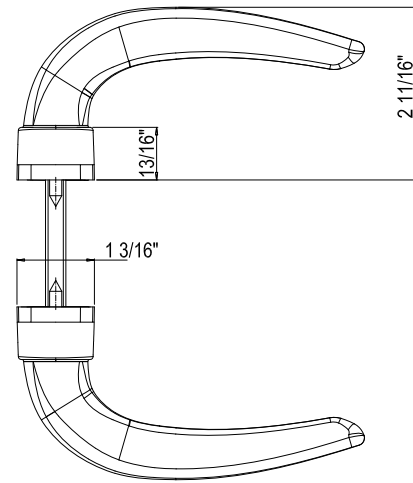

fapim

fapim

ART# 9730

ART# 5601

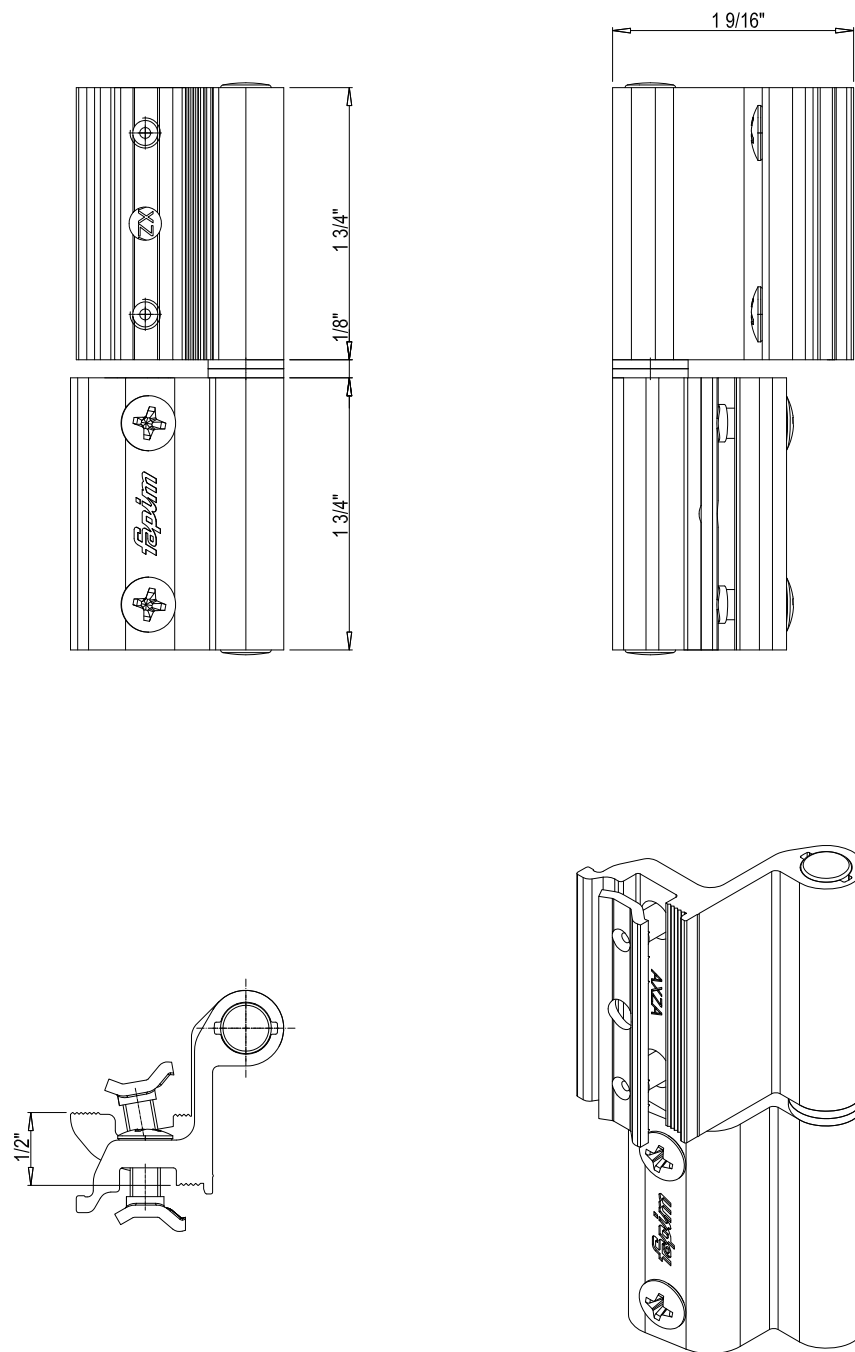

fapim

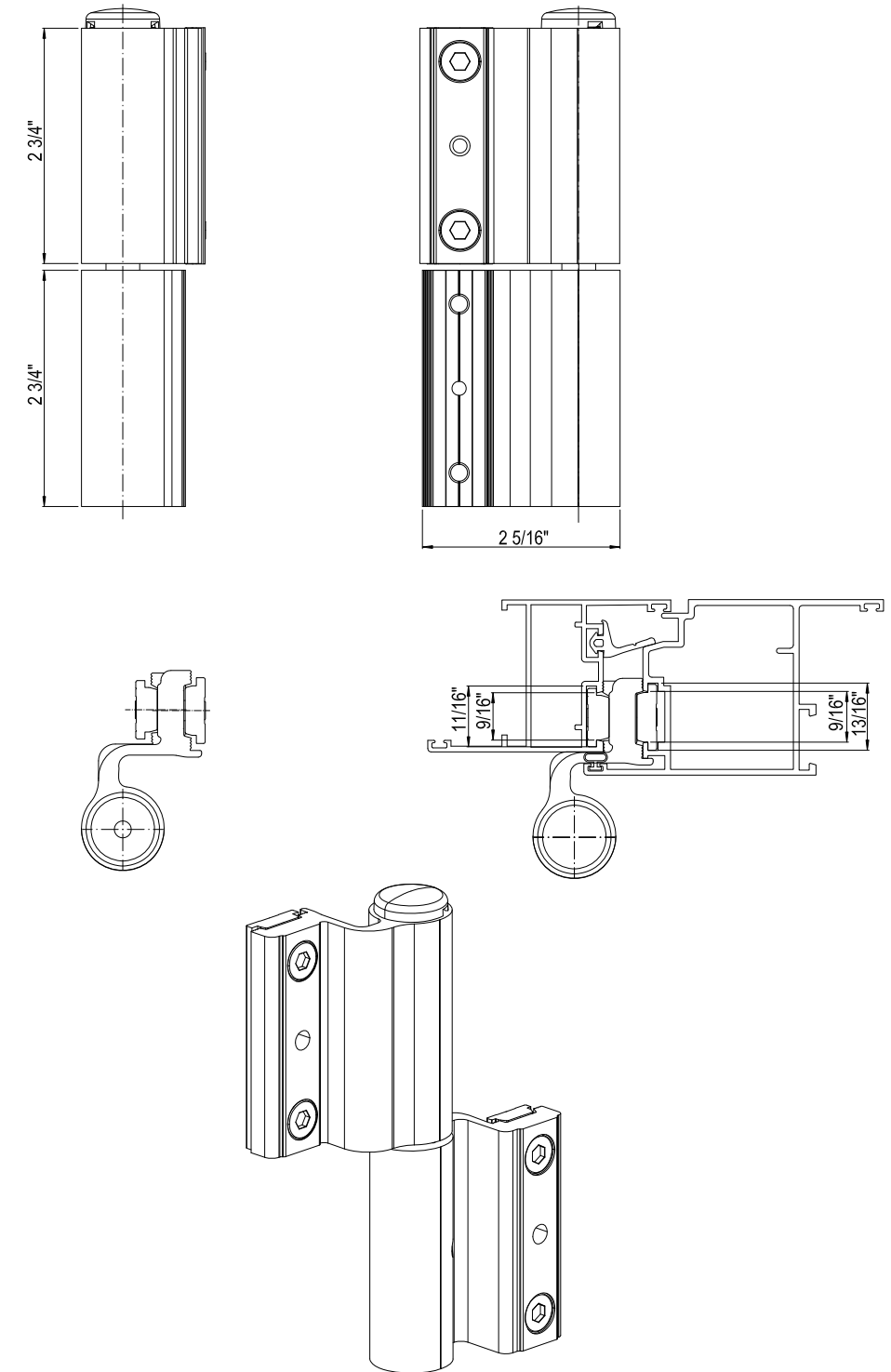

fapim

ART# 7010V

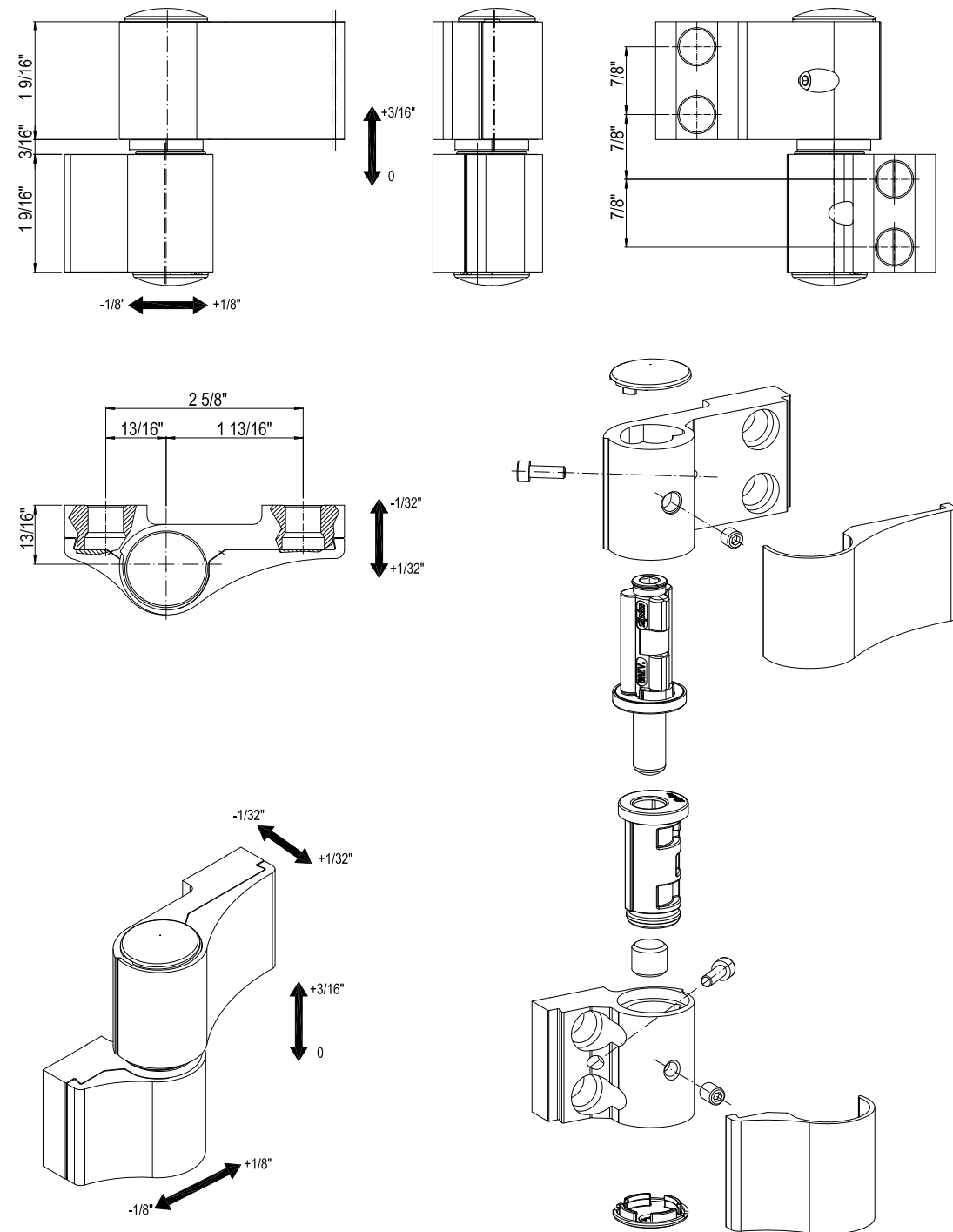

fapim

ART# 7010

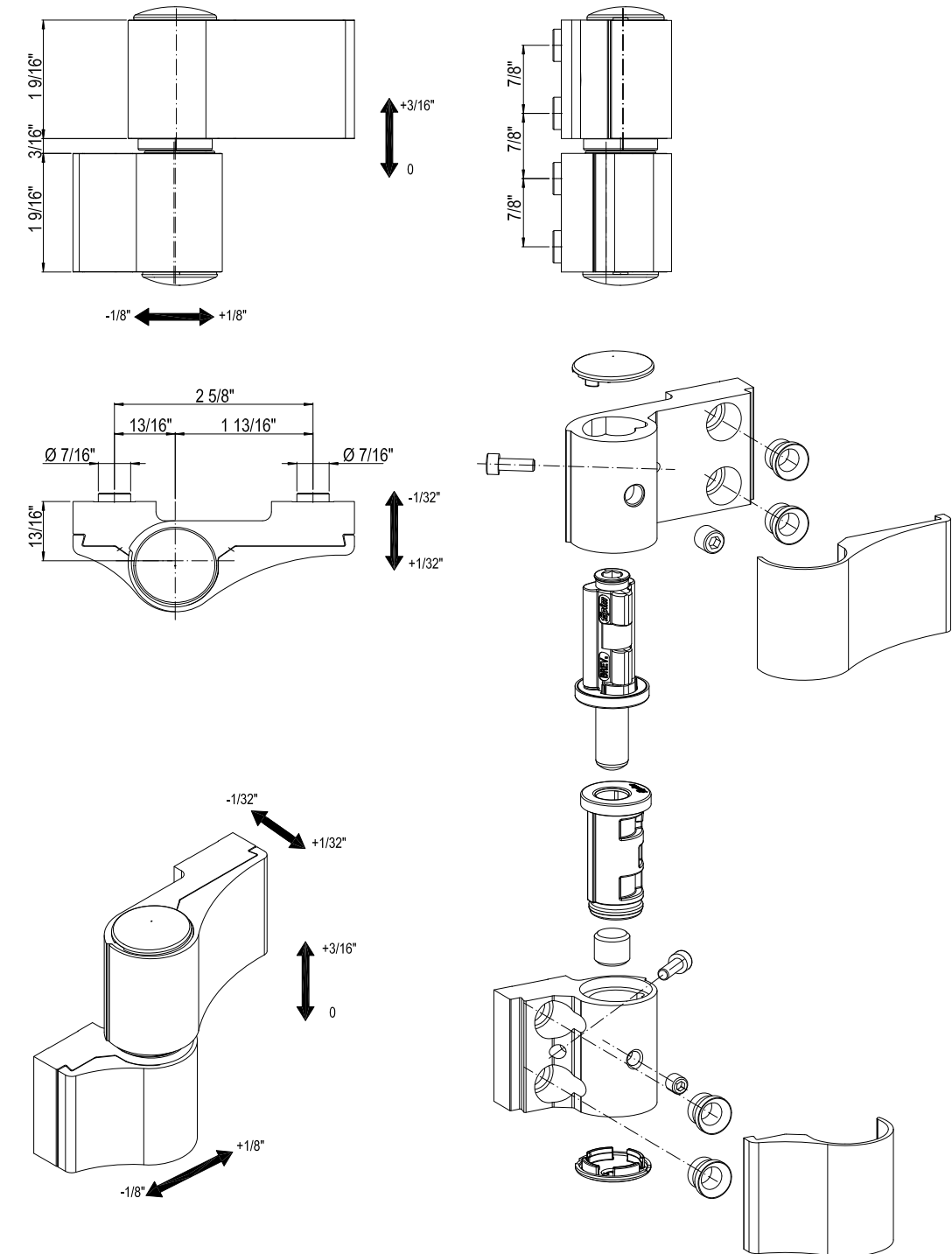

fapim

ART# 7040V

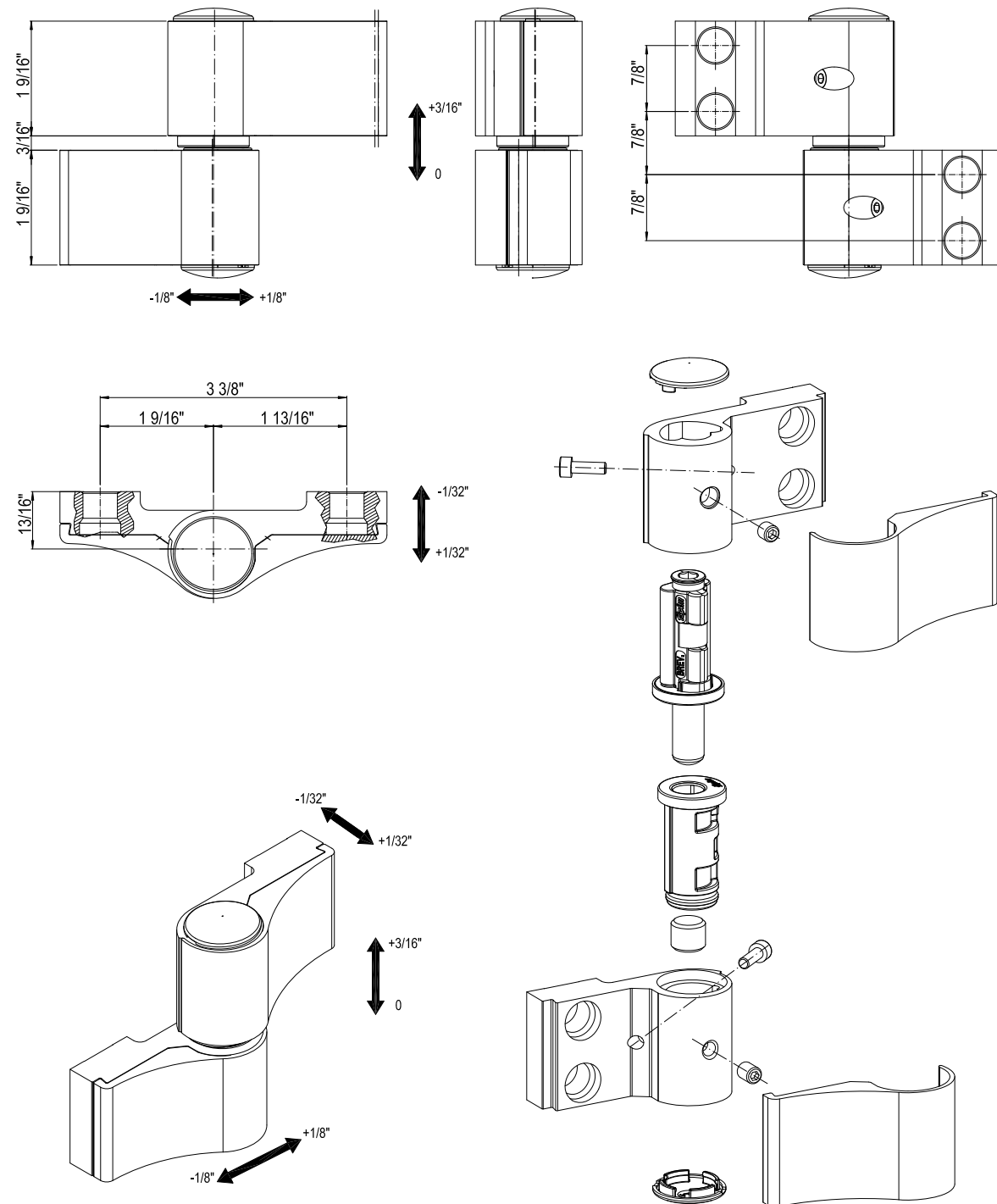

ART# 2755CG

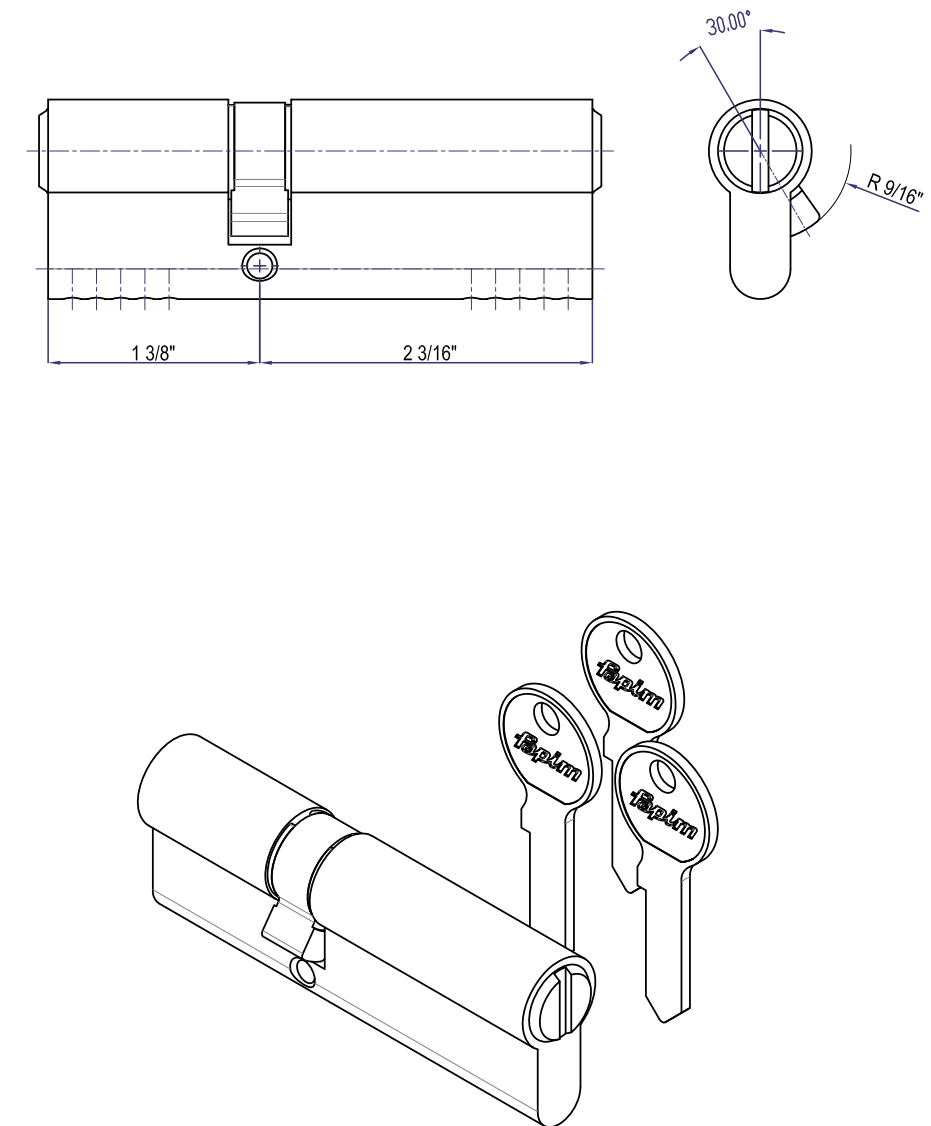

fapim.

fapim.

ART# 2100B

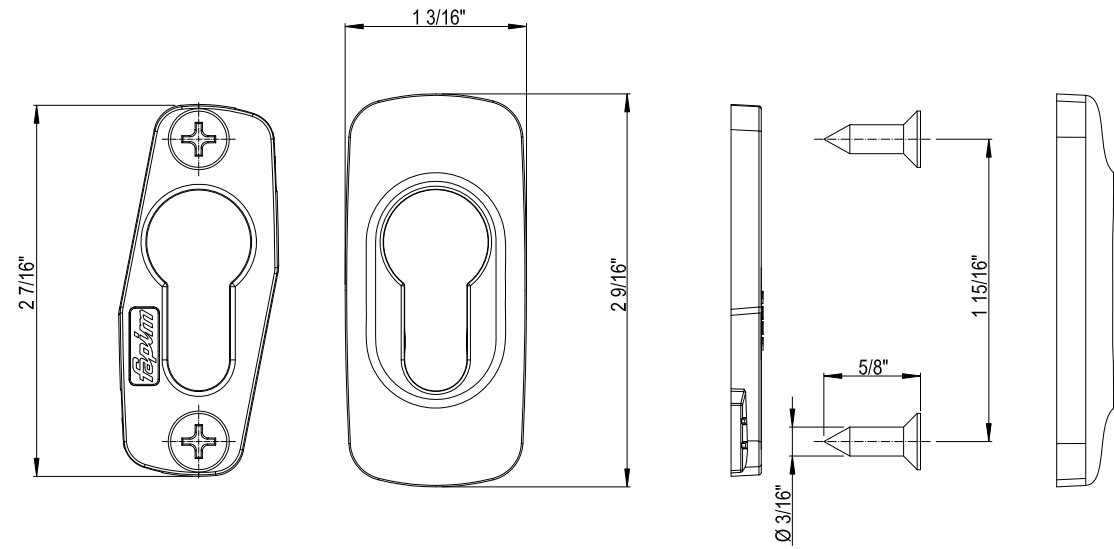

ART# 2100C

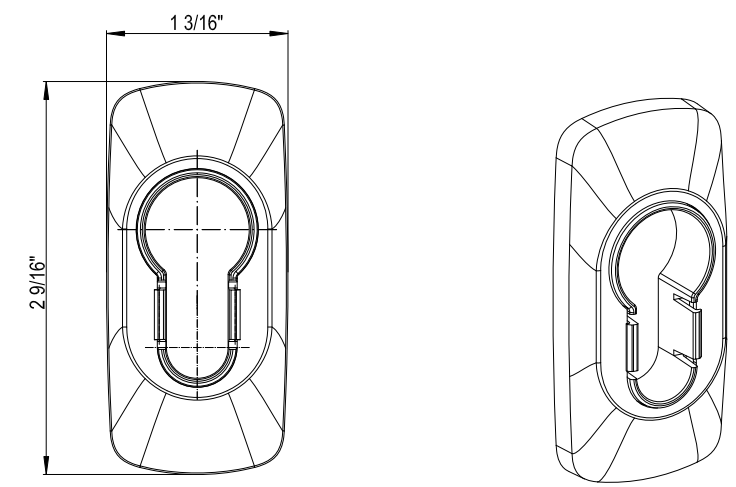
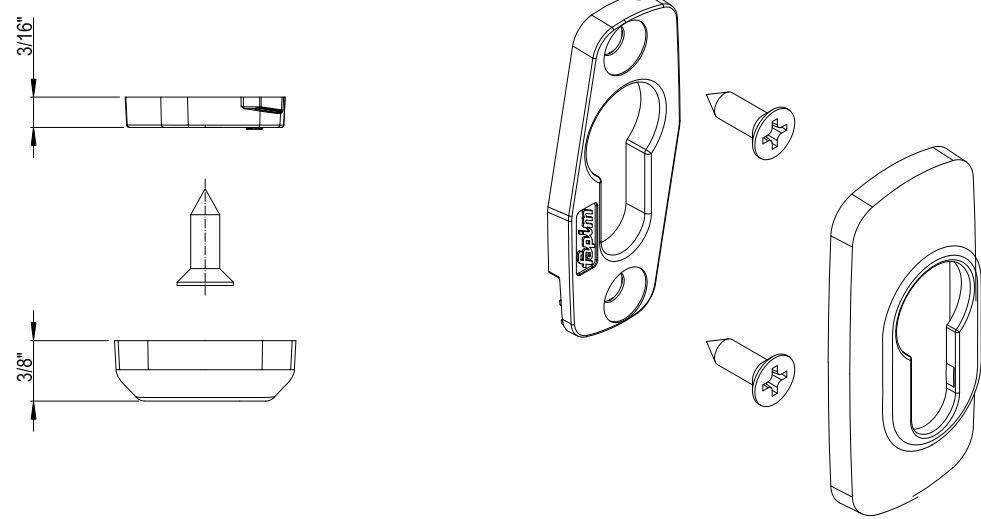
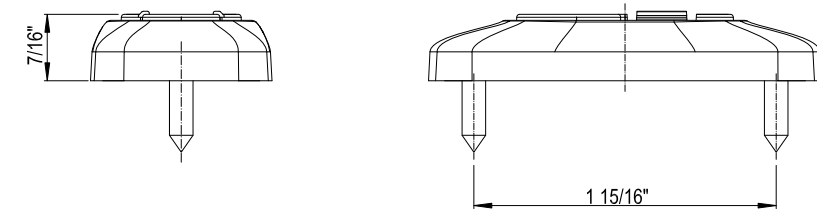

fapim

fapim

ART# 2501B

ART# 2501C

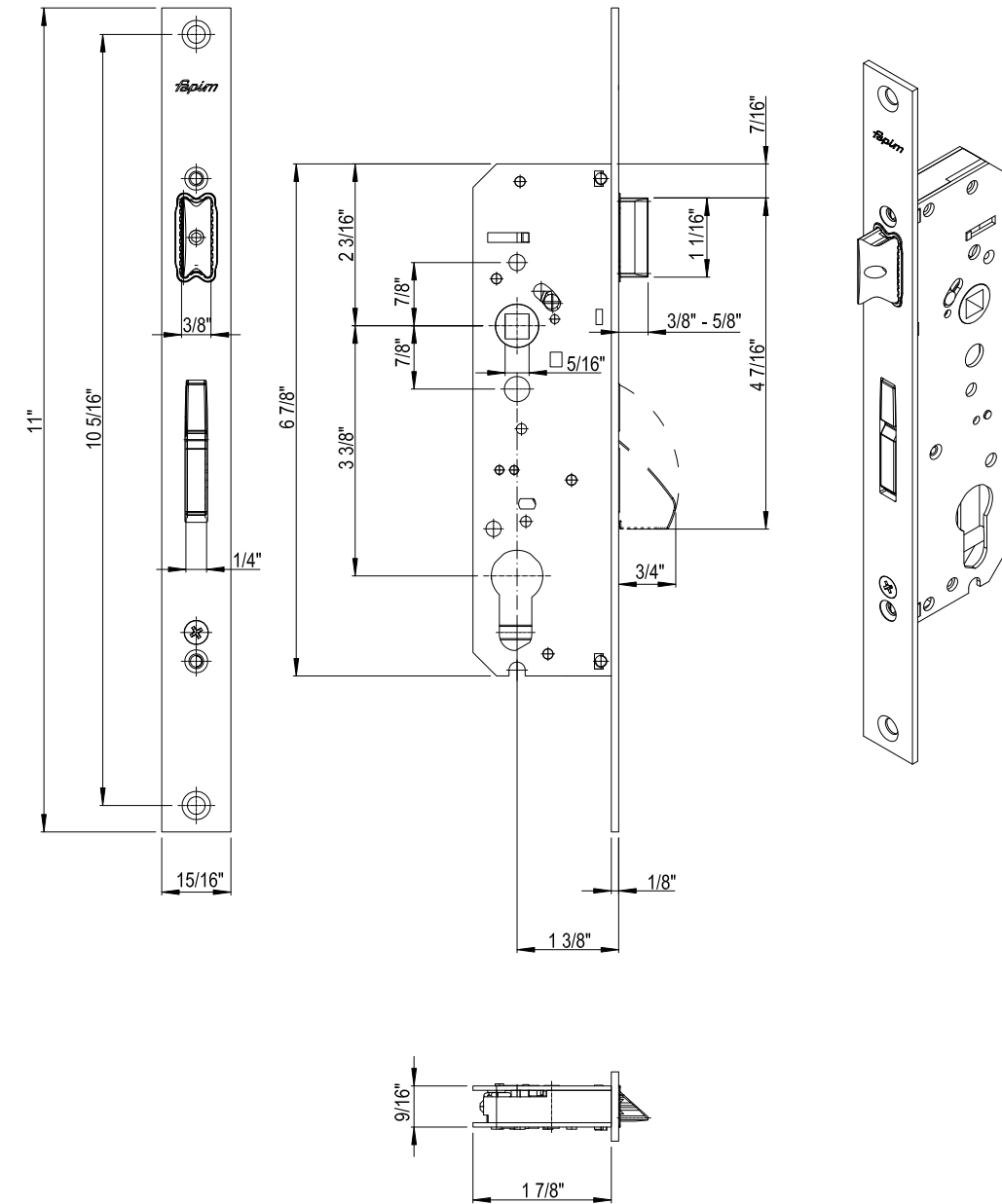
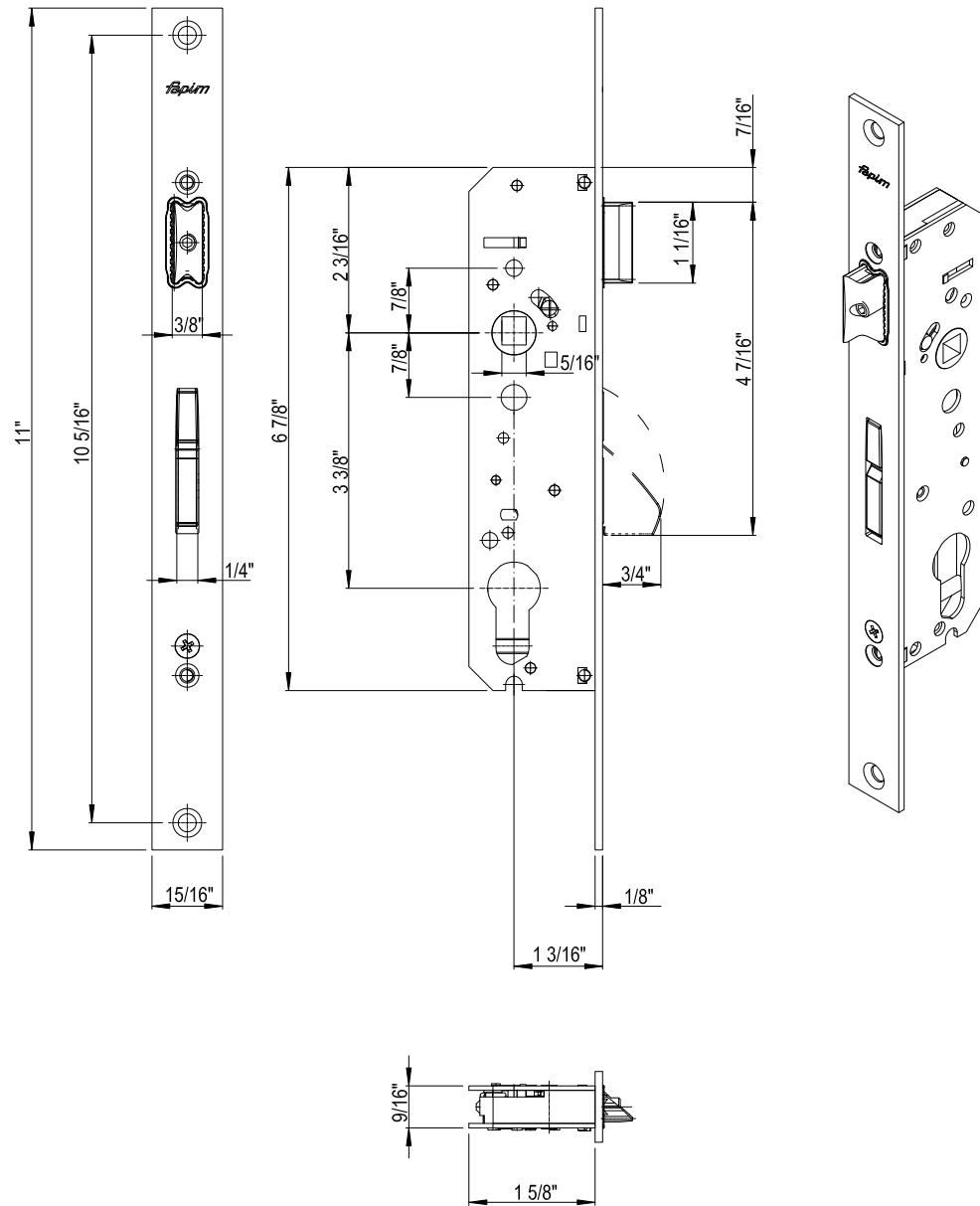

fapim

fapim

ART# 6620

ART# 6604A

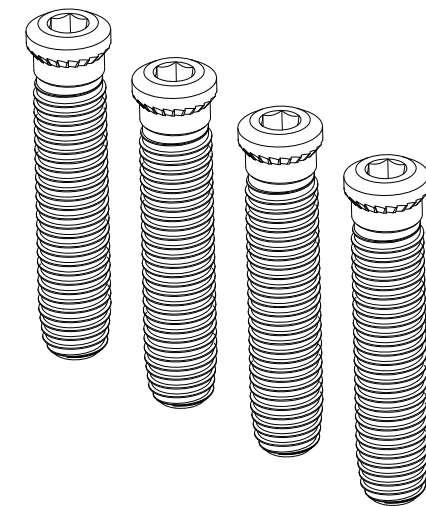
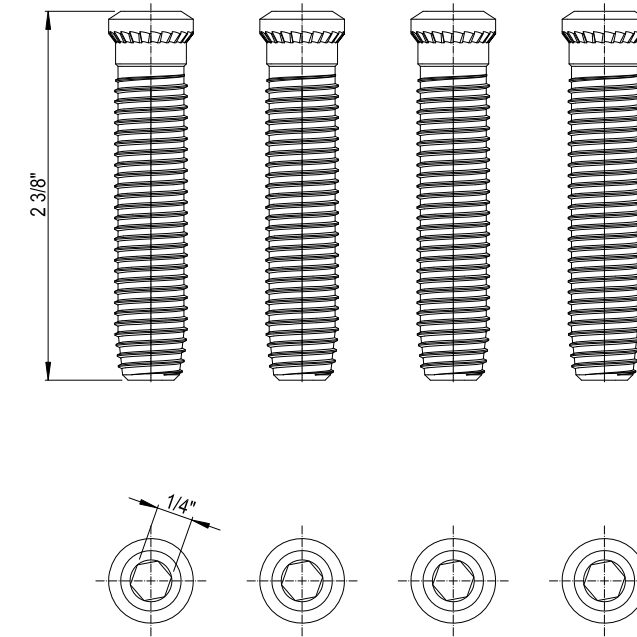
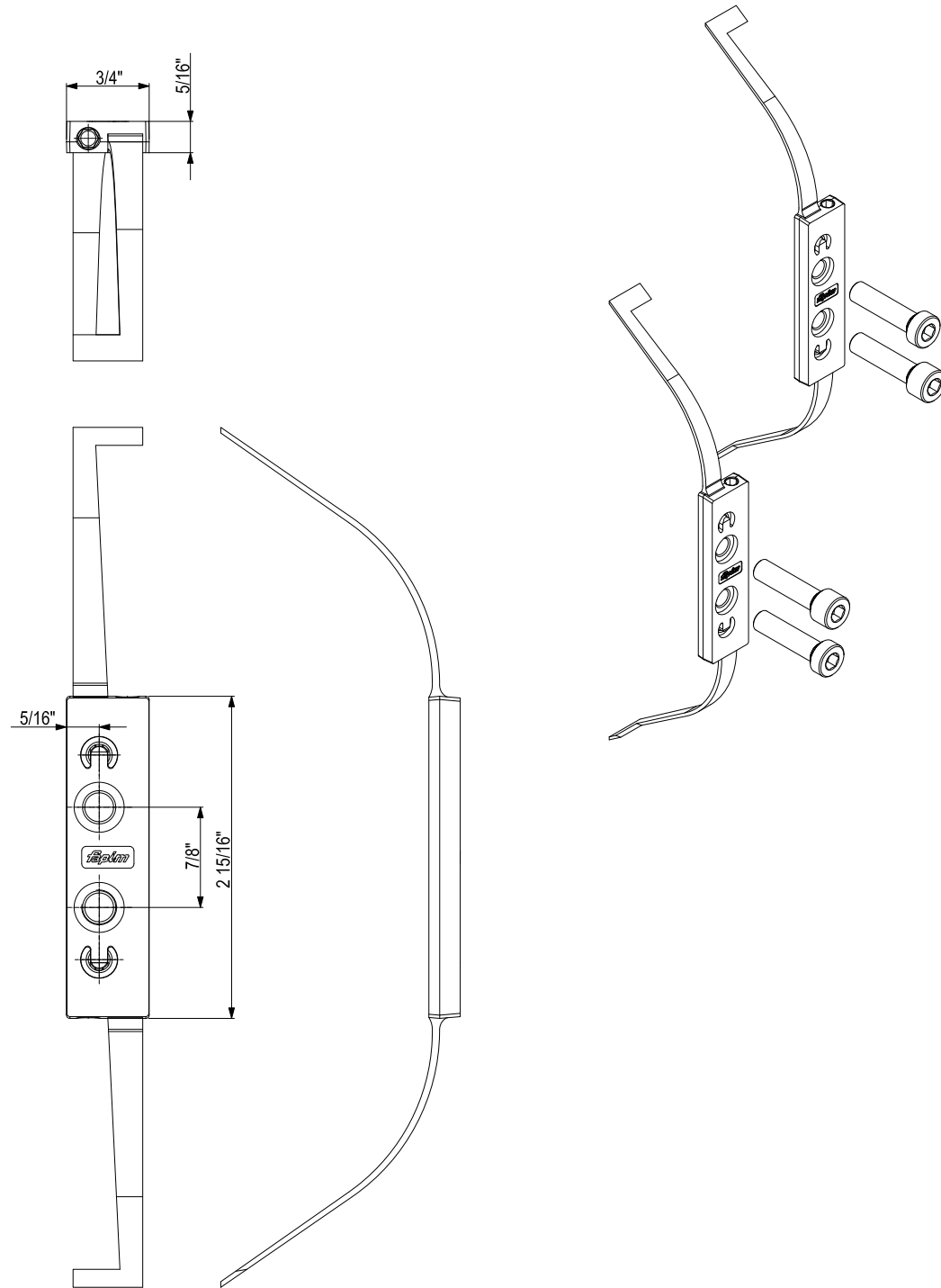

fapim

fapim

AluminTechno, LLC is the leading aluminum extrusions manufacturer and profile systems engineering company on the territory of Central and Eastern Europe.

The enterprise is equipped with state-of-art machinery supplied by the leading manufacturers from the USA, Germany and Italy. At AluminTechno the complete production cycle is being performed: from primary aluminum foundry casting works to extrusion of aluminum moldings followed by coating or anodizing. The main manufacturing facilities are modern foundry complexes, high-performance press lines, advanced coating and anodizing shops.

Currently AluminTechno, LLC produces a wide range of aluminum extrusions for architectural systems: more than 1,000 various configurations. Standard length of extruded profiles is from 10' to 22'-4". Maximum available length for mill finish extrusions 25', for powder coated 22'-11", for anodized 23'-7". Polymeric coating thickness is from 60 to 80 micron, any RAL color available. The range of anodic finishes includes 11 colors and 2 different types of surface finish (standard and polished), which gives the opportunity to get 22 different effects. The anodic coating thickness can vary from 10 to 15 micron. Enterprise's annual output is 45,000 tons of extruded profiles.

The range of architectural systems engineered by AluminTechno, LLC includes more than 20 products for construction, architecture and design. The fast growth of the company with average 3 new products launched annually makes AluminTechno, LLC one of the industry leaders. Our engineering department is always ready to design solutions for specific projects, which allow us to get involved in construction and renovation projects all over the world.

The quality control management system at AluminTechno, LLC is compliant with the requirements of ISO 9001:2009 International Standard of TÜV CERT system. Most of top line products have successfully passed major **ASTM, AAMA** and **TAS** tests.

The quality of aluminum moldings' finish is proven by three international certificates: **QUALICOAT, SEASIDE** and **QUALANOD**. All AluminTechno's aluminum products distributed by Professional Grade Aluminum, Corp. are either coated with Swiss made materials by IGP that meet or exceed AAMA 2603, or anodized to meet QUALANOD requirements.



AluminTechno, LLC Production Facility







Professional Grade Aluminum
701 39th Street Brooklyn NY 11232

Tel 718.382.8400
Fax 718.382.8401