

ALT SL160

Mounting instructions
for the lift and slide door system



Contents

General rules 2

Convention 5

Drawing of the typical door 5

Mounting instructions of ALTS160 6

General rules

The proper door assembly is a compulsory condition for guaranteeing of the high performance characteristics of the product. In the present instructions there is shown the recommended step by step installation process of the ALT SL160 door. All the existing norms and regulations applicable to the installation of lift and slide doors must be strictly observed. The contents of this Instructions can not be the basis for legal claims. ALUTECH keeps the right to make changes and additions to the lift and slide door constructions as well as to the present Instructions.

1. Security measures

- Carefully read the installation instructions before assembly.
- Do not work alone. Two or more people are required. Use safe ways to lift large and heavy structures.
- Be careful while handling the glass. Broken or cracked glass can cause serious injury.
- Use protective equipment (for example, goggles, gloves, protective headphones, etc.).
- Use safe hand/electric tools and follow the assembly instructions.
- Be careful when working at height.

The mounting process of lift and slide doors must be carried out only by the qualified staff who is acquainted with the technological process of the door mounting, trained and provided with safety instructions. The national safety rules and regulations must be strictly observed while making the installation.

The means of protection

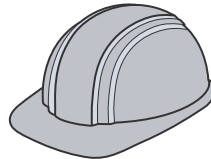
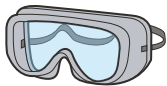

2. Aperture requirements

The prepared apertures must meet the following requirements:

- Apertures must be of square shape.
- The aperture framing surfaces must be smooth, without plaster infiltrations and cracks.
- Any deviation of the working surfaces from the vertical and horizontal lines should not exceed 0.5 mm/m, but not more than 3 mm.
- The space required for the door installation must be free of heating and ventilation pipelines, etc.

General rules (Continuation)

3. Frame installation rules:

- The frame should be placed symmetrically to the vertical axis of the aperture.
- While making the frame assembly, its components must be vertically and horizontally leveled.
- The lower supporting part of the frame should adjoin with the floor along the entire length of the aperture. The local gaps of not more than 5 mm as well as the slopes with a total deviation of not more than 5 mm from the horizontal level are acceptable. These deviations must be eliminated by the installation of the gaskets in the fixing points.
- The difference between the lengths of the diagonals, measured at the end points of the door frame, should not exceed 2 mm.
- The frame must be securely fixed and does not pose a threat to human life and health.

The fixing elements should be chosen in accordance with the material used for the apertures. Screws must be made of steel with no less than 9 microns of anti-corrosion coating. The strength class of the screws is not less than 5.6. All fasteners must be resistant to corrosion.

4. Door installation

It is recommended to make the visual examination of the door for:

- The correct and full range of the ordered material (size, opening type, color, accessories, glazing, etc.).
- The integrity and availability of all the system components.
- The tight corner joining, absence of cracks, holes, missing areas and/or other damages.

The aperture as well as the rough (finished) floor must be completely prepared before the door installation. It is necessary to ensure proper waterproofing, steam isolation, and effective insulation of the erection joint in accordance with the project documentation. In case of having any construction works in the area of the lift and slide door installation, the door itself should be protected from spray of solution, cement, gypsum, caustic substances (acids and alkalis), paint materials, etc.

The assembly equipment

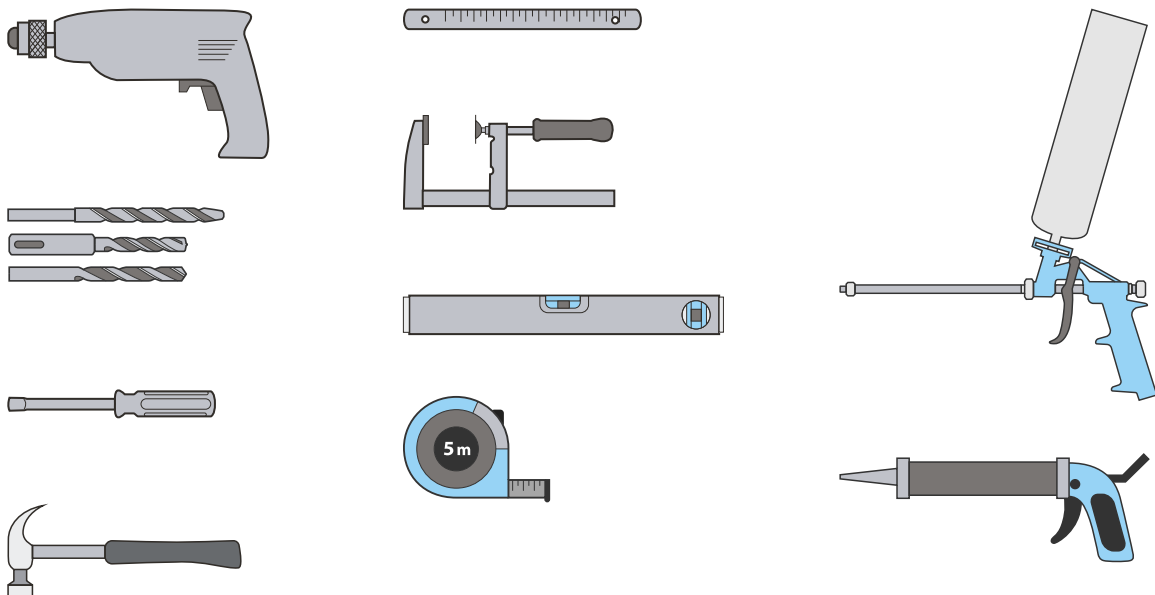

General rules (Continuation)

5. Door adjustment and testing

The profile protective film should be removed immediately after completing of the installation work. Impure areas of the door should be cleaned. Cleaning can be done with pure water or non-aggressive detergent solutions using a sponge or a soft cloth.

Do not use abrasive cleaners or products containing alcohols.

The working capacity of all the active sashes must be checked by the five times repeating of the following operations: lift the sash—move aside—move back—pull down.

For the doors equipped with the electric motor, all the program modes should be checked.

A complete removal of the protective film should be done immediately after the completing of the installation.

6. Door delivery

The delivery of the assembled door to the Customer is carried out in the following order:

- The representative of the Organization, responsible for the assembly, makes a complete demonstration of the functional performance of the lift and slide door.
- The operational documentation is filled.

Convention



Attention

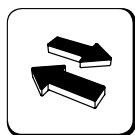

Replacement
is possible

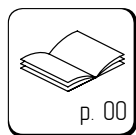

See page №

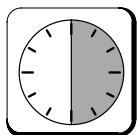

Wait for
30 min

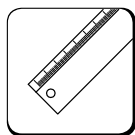

Ruler
measuring

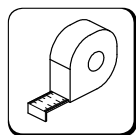

Tape
measuring

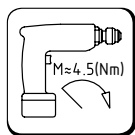

Tightening



Surface
cleaning

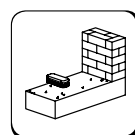

Aperture
cleaning

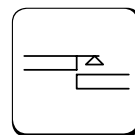

Flatness

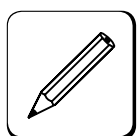

Marking

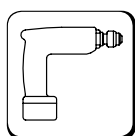

Screwing

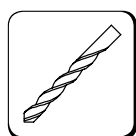

Drilling

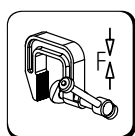

Clamping

Drawing of the typical door

- H - frame height
- H1- sash height
- H2- door height taking into account
the supporting profile
- L - door width
- L1 - sash width



$$\frac{H1}{L1} \leq 2.5$$

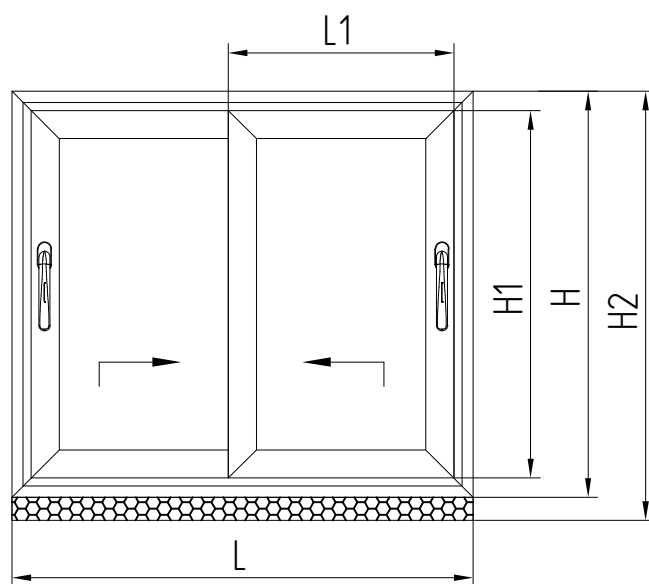

Mounting instructions of ALT SL160

1

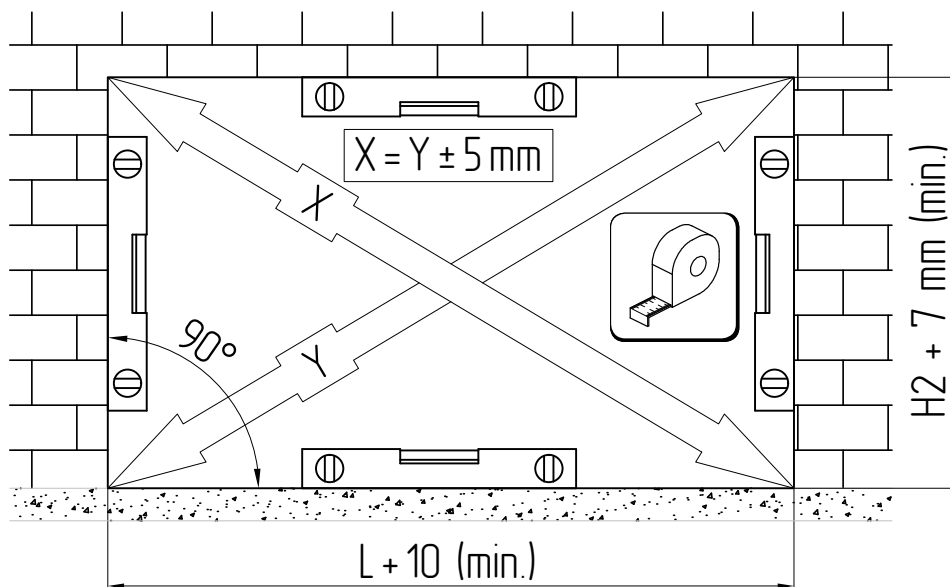
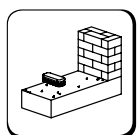

2

Before the frame installation, the aperture should be prepared in accordance with the project documentation.



The mounting plates should be installed in advance.

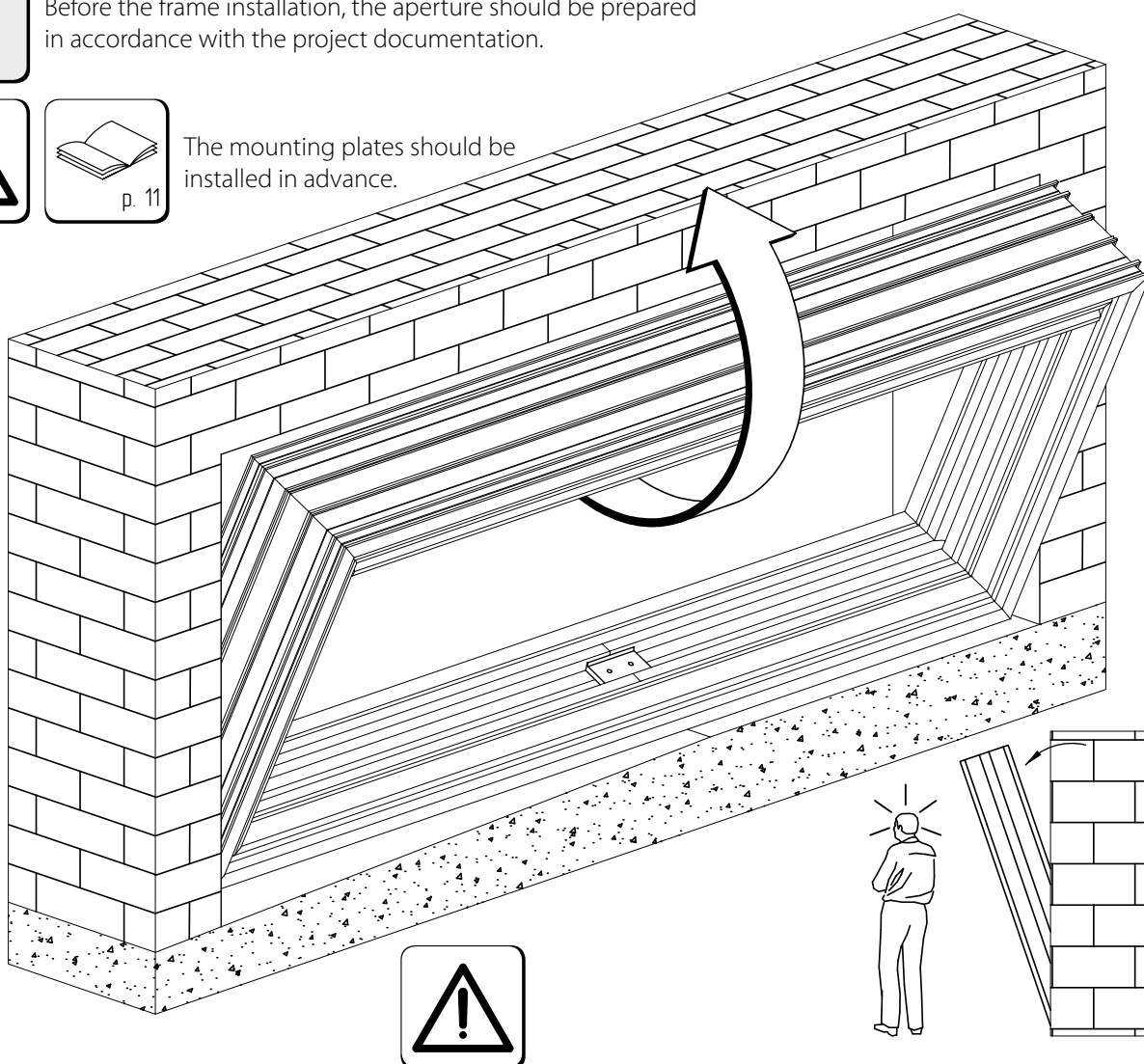

Mounting instructions of ALT SL160 (Continuation)

3

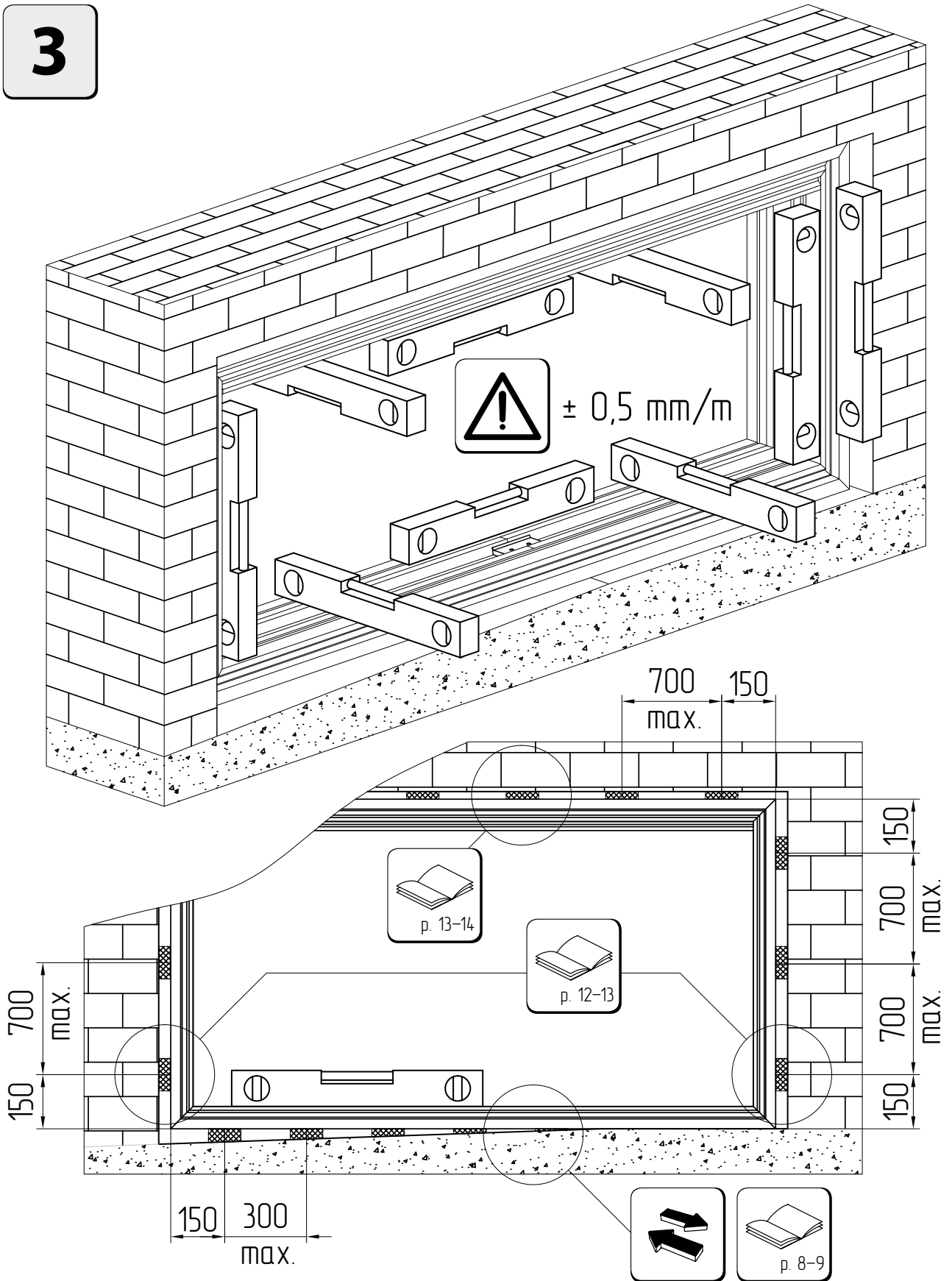

Mounting instructions of ALT SL160 (Continuation)

The scheme of bearing and distance supports installation scheme

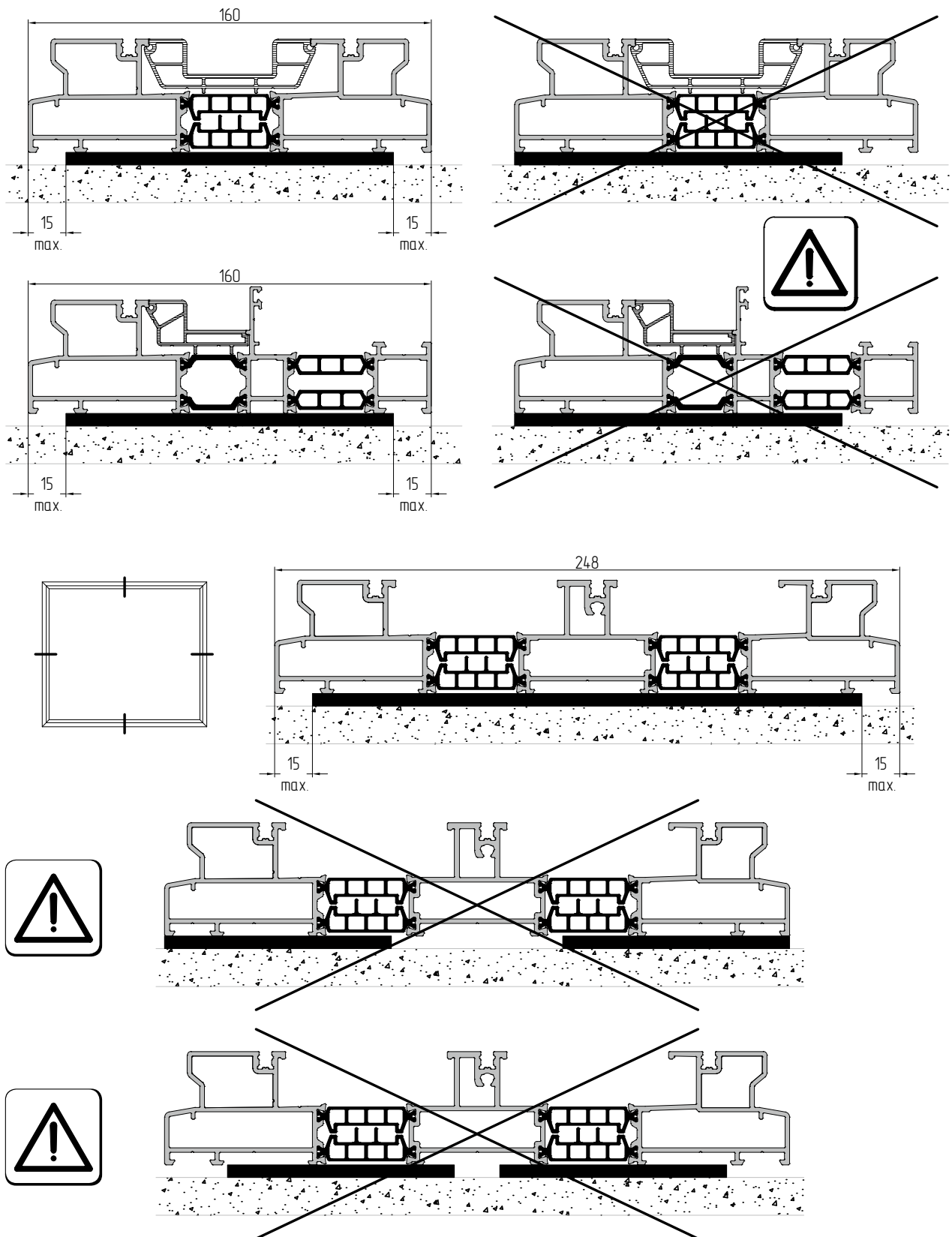

Mounting instructions of ALT SL160 (Continuation)

The installation scheme of the supporting profiles at the bottom of the door

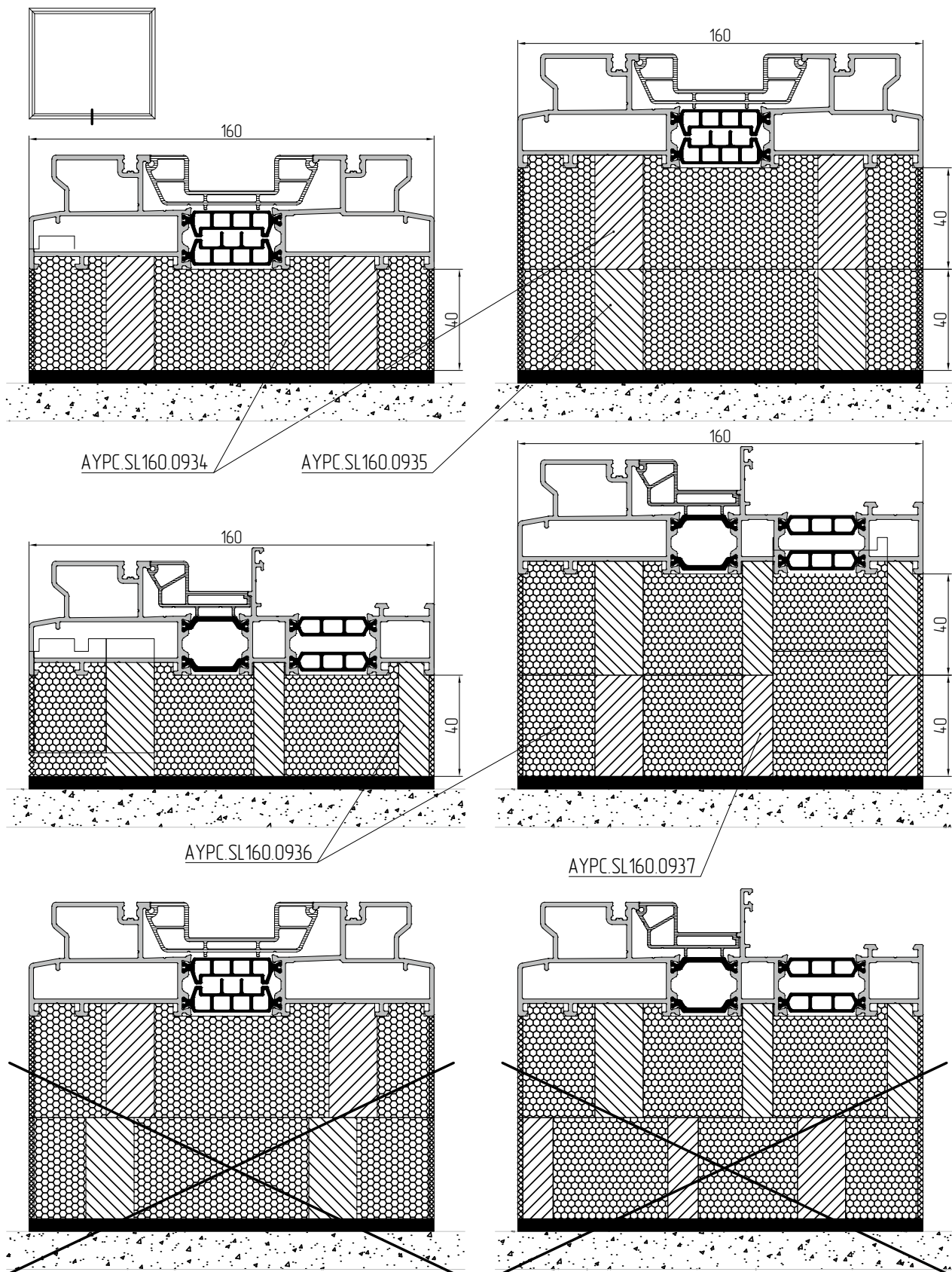

Mounting instructions of ALT SL160 (Continuation)



Fixation of the supporting profiles
AYPC.SL160.0936 and AYPC.SL160.0937.

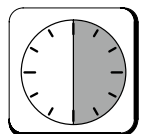
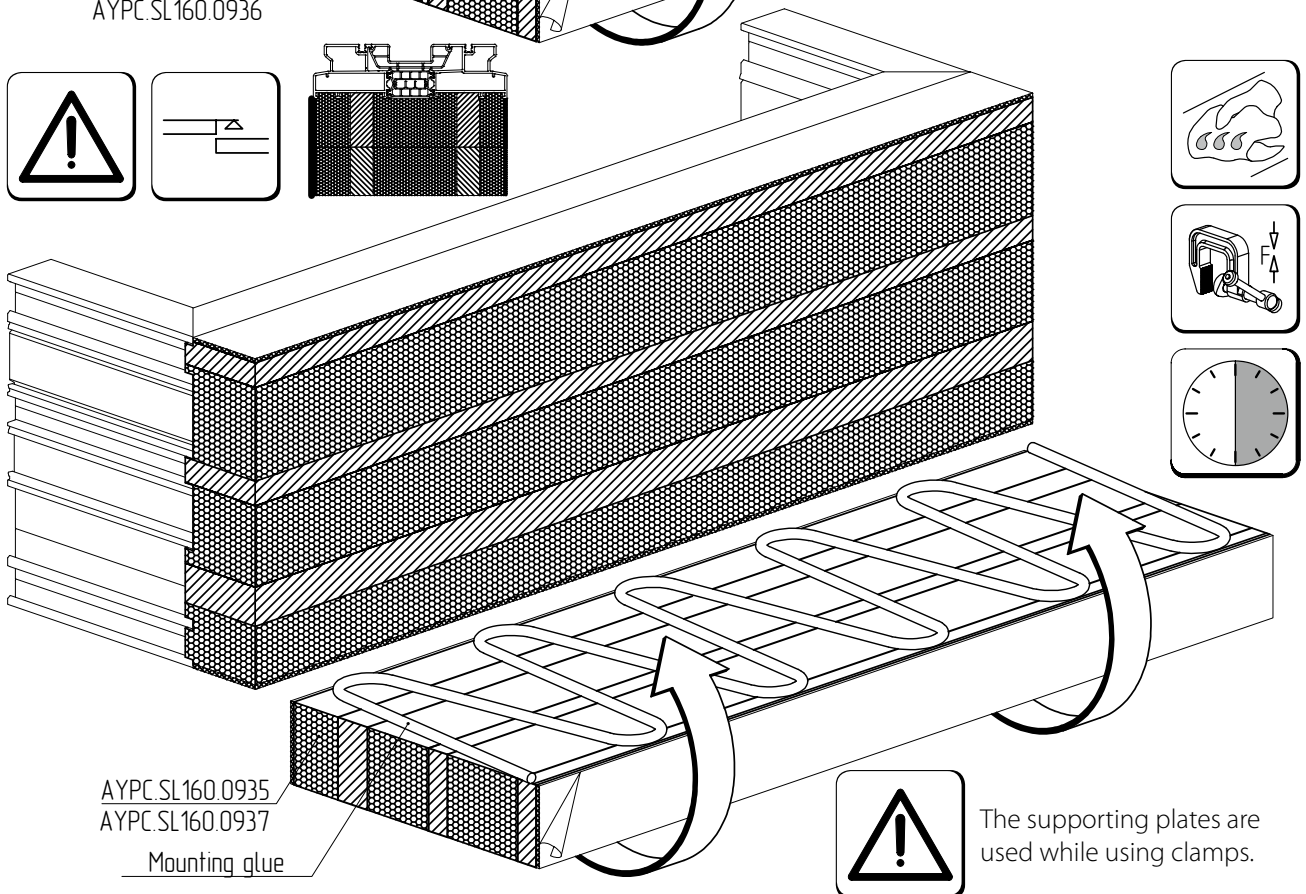
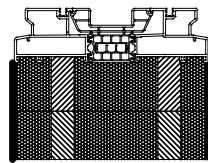
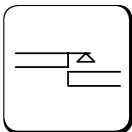
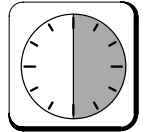
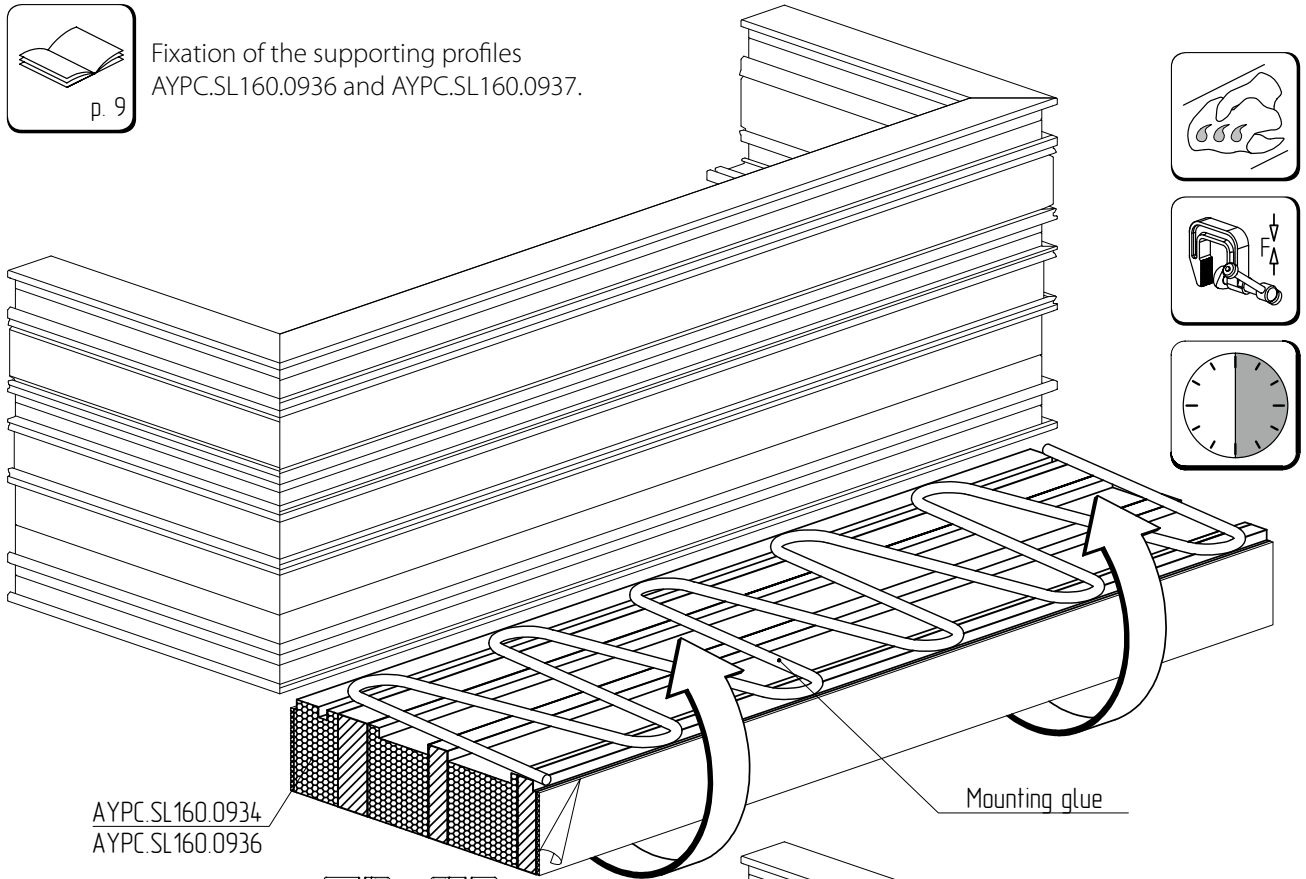

The supporting plates are used while using clamps.

Mounting instructions of ALT SL160 (Continuation)

4

The fixation requirements are the same for both the mounting plates and anchors (additional information see on pages 12–13).

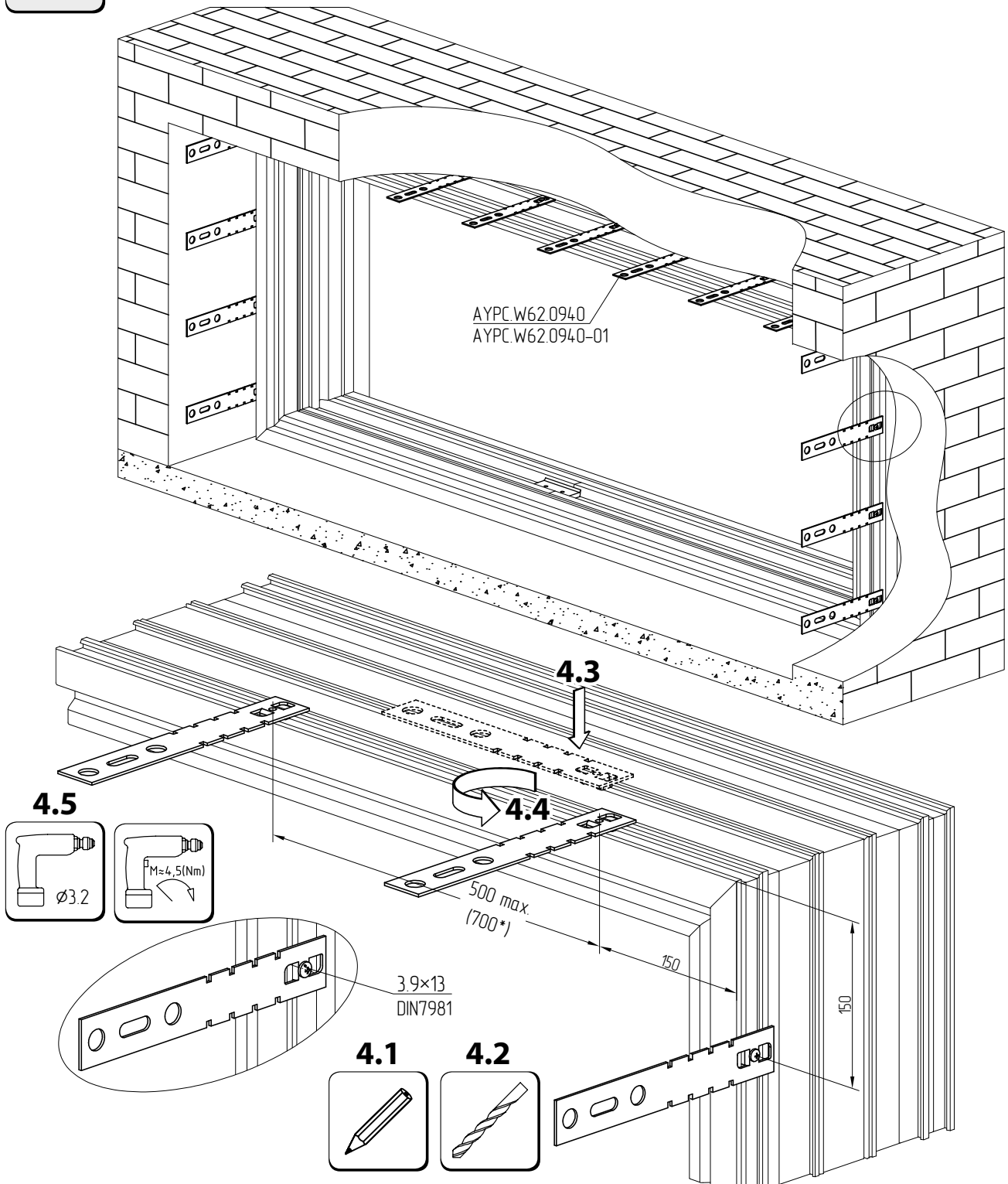

Type of fasteners should be chosen in accordance with the material of the aperture.
Fixing points (on the mounting plates or anchors) should be placed in the area of the installation of the distance supports.

* In case of using of the metal anchors.

Mounting instructions of ALT SL160 (Continuation)

Door installation variants

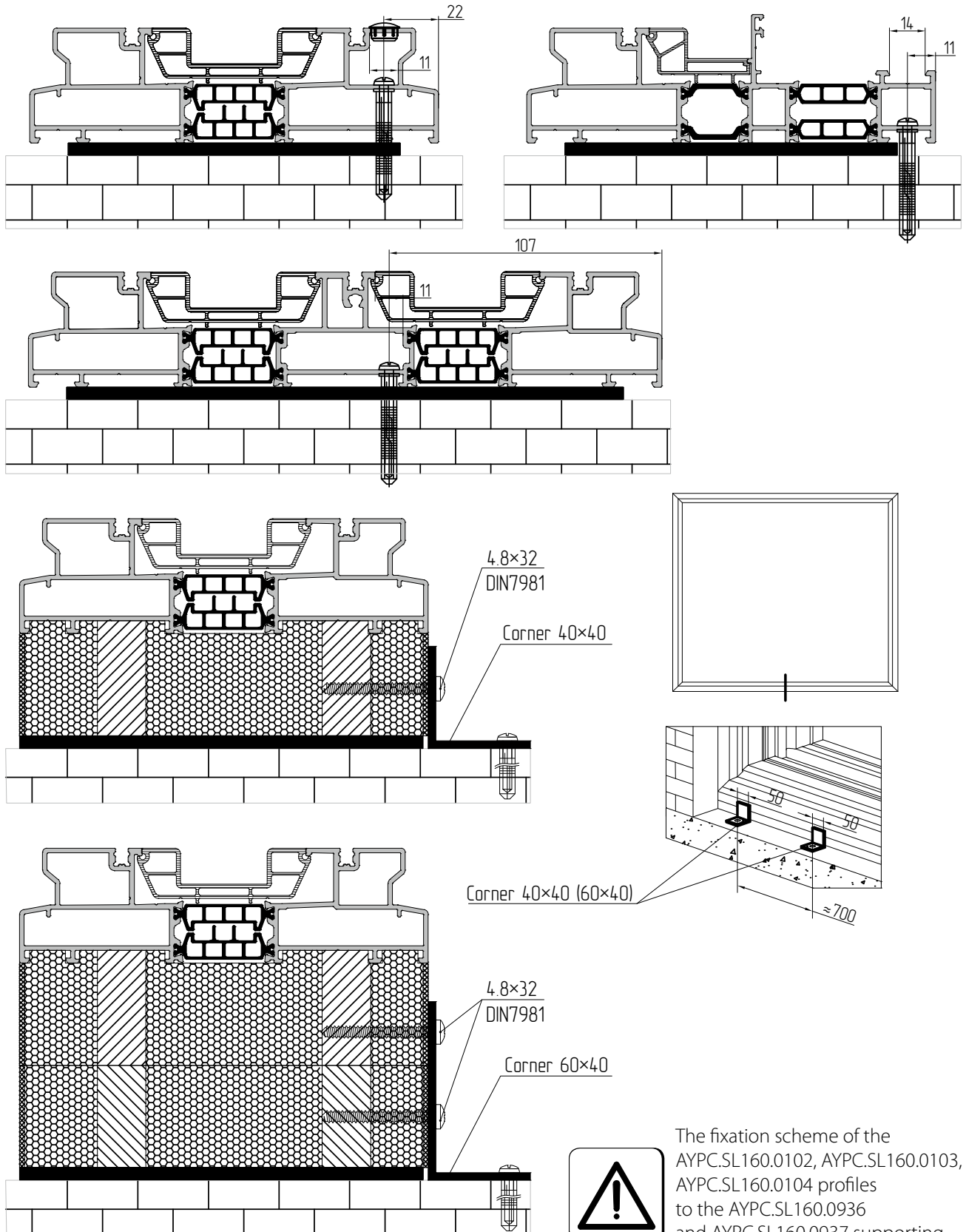

The fixation scheme of the AYP.C.SL160.0102, AYP.C.SL160.0103, AYP.C.SL160.0104 profiles to the AYP.C.SL160.0936 and AYP.C.SL160.0937 supporting profiles is equal.

Mounting instructions of ALT SL160 (Continuation)

Door installation variants

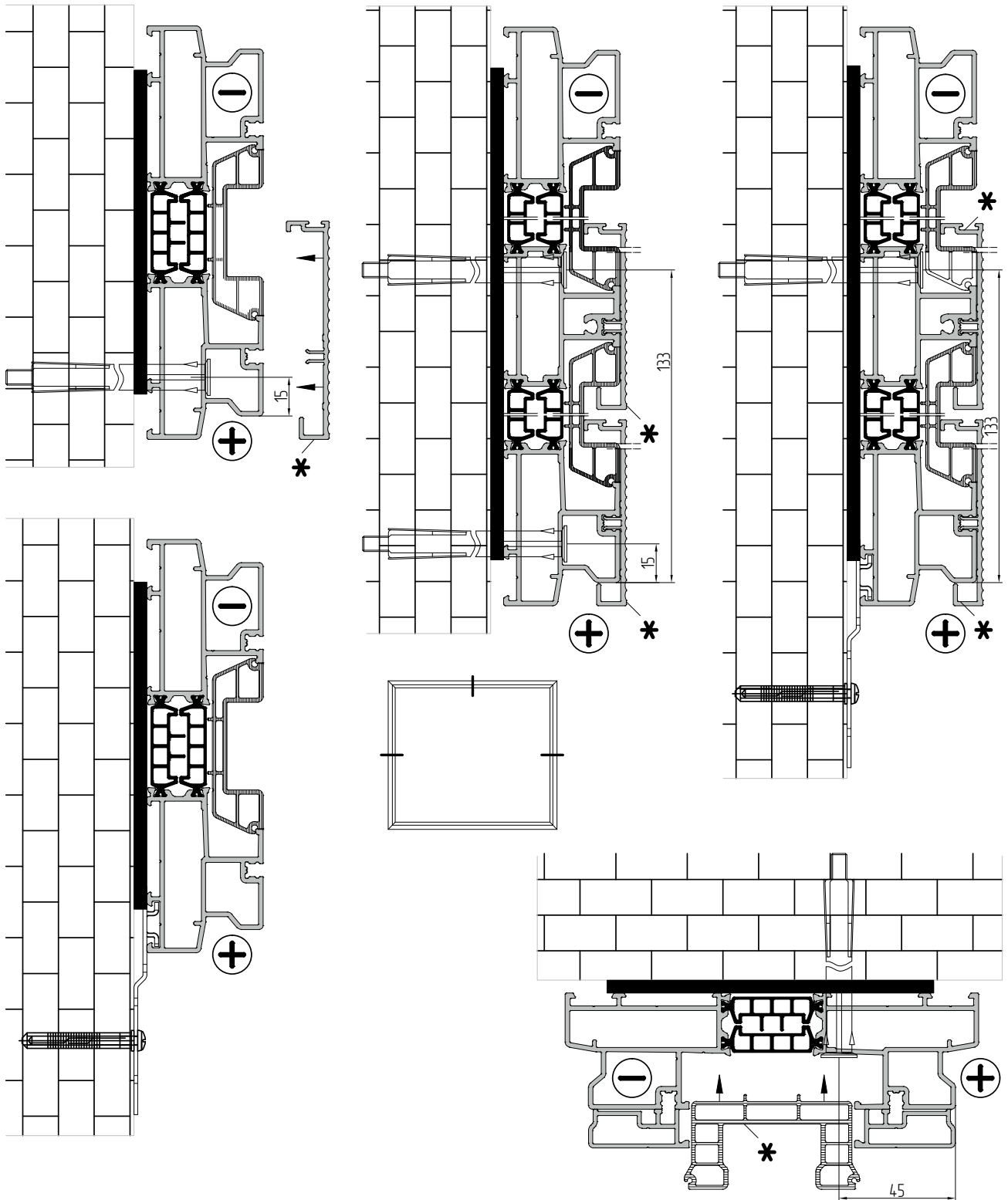

The mounting holes should be placed in the area of distance supports installation.

* Should be placed after the installation of the assembled door in the aperture in accordance with the guidance of the technical manual.

The type of fasteners should be chosen depending on the material used for the aperture.

Mounting instructions of ALT SL160 (Continuation)

Door installation variants

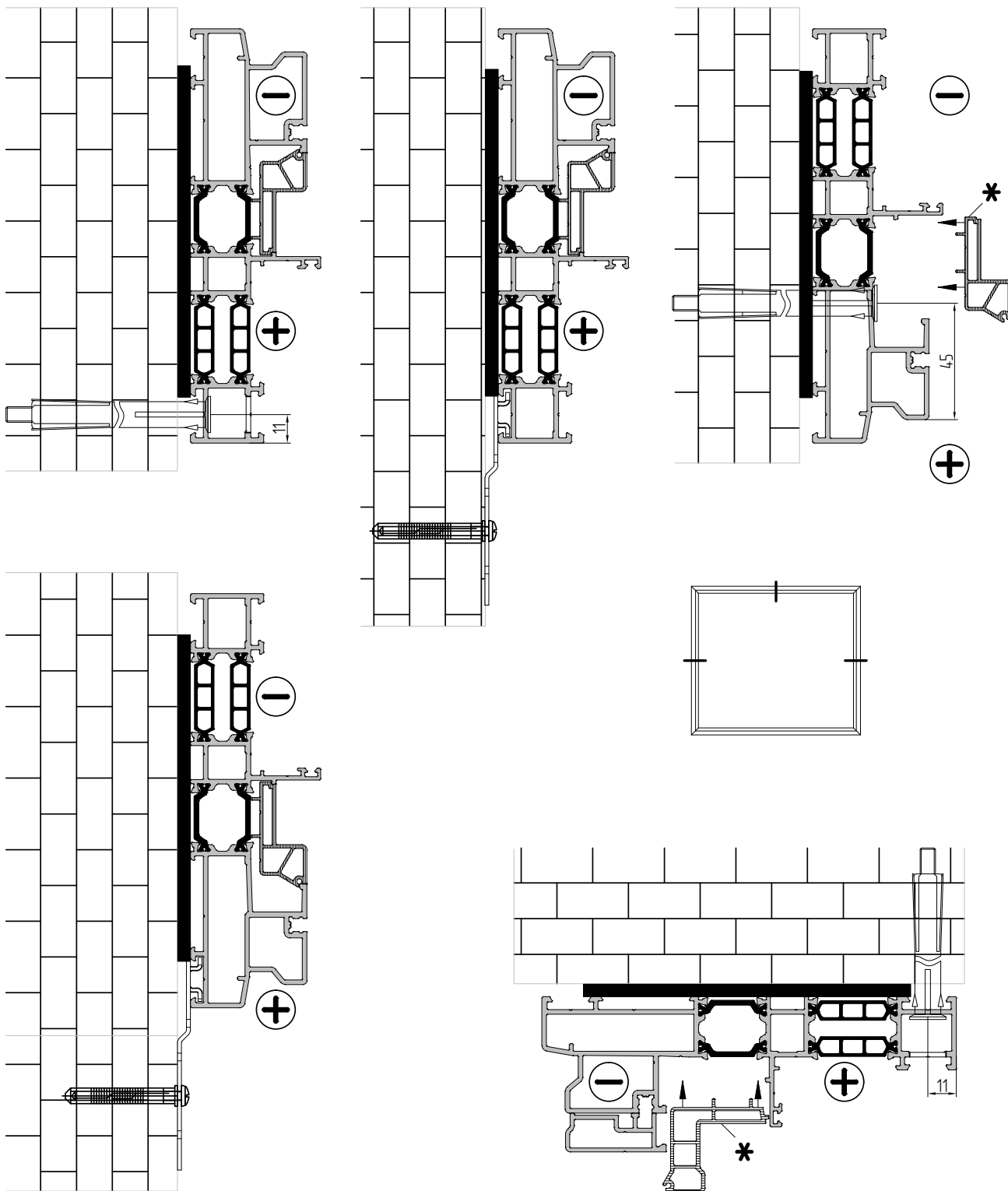

The mounting holes should be placed in the area of distance supports installation.

* Should be placed after the installation of the assembled door in the aperture in accordance with the guidance of the technical manual.

The type of fasteners should be chosen depending on the material used for the aperture.

Mounting instructions of ALT SL160 (Continuation)

Door installation variants

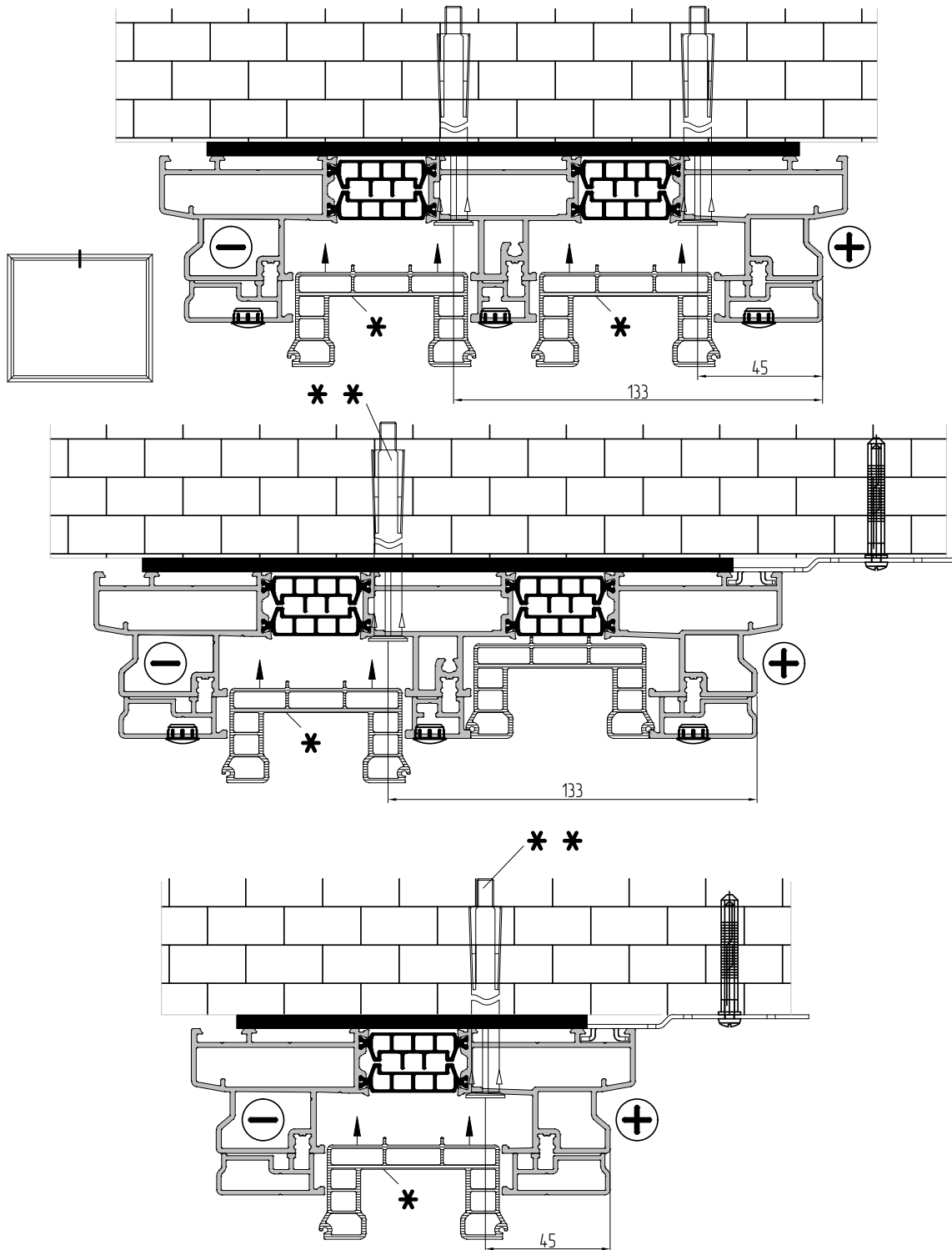

The mounting holes should be placed in the area of distance supports installation.

* Should be placed after the installation of the assembled door in the aperture in accordance with the guidance of the technical manual. The type of fasteners should be chosen depending on the material used for the aperture.

** See page 16.

Mounting instructions of ALT SL160 (Continuation)

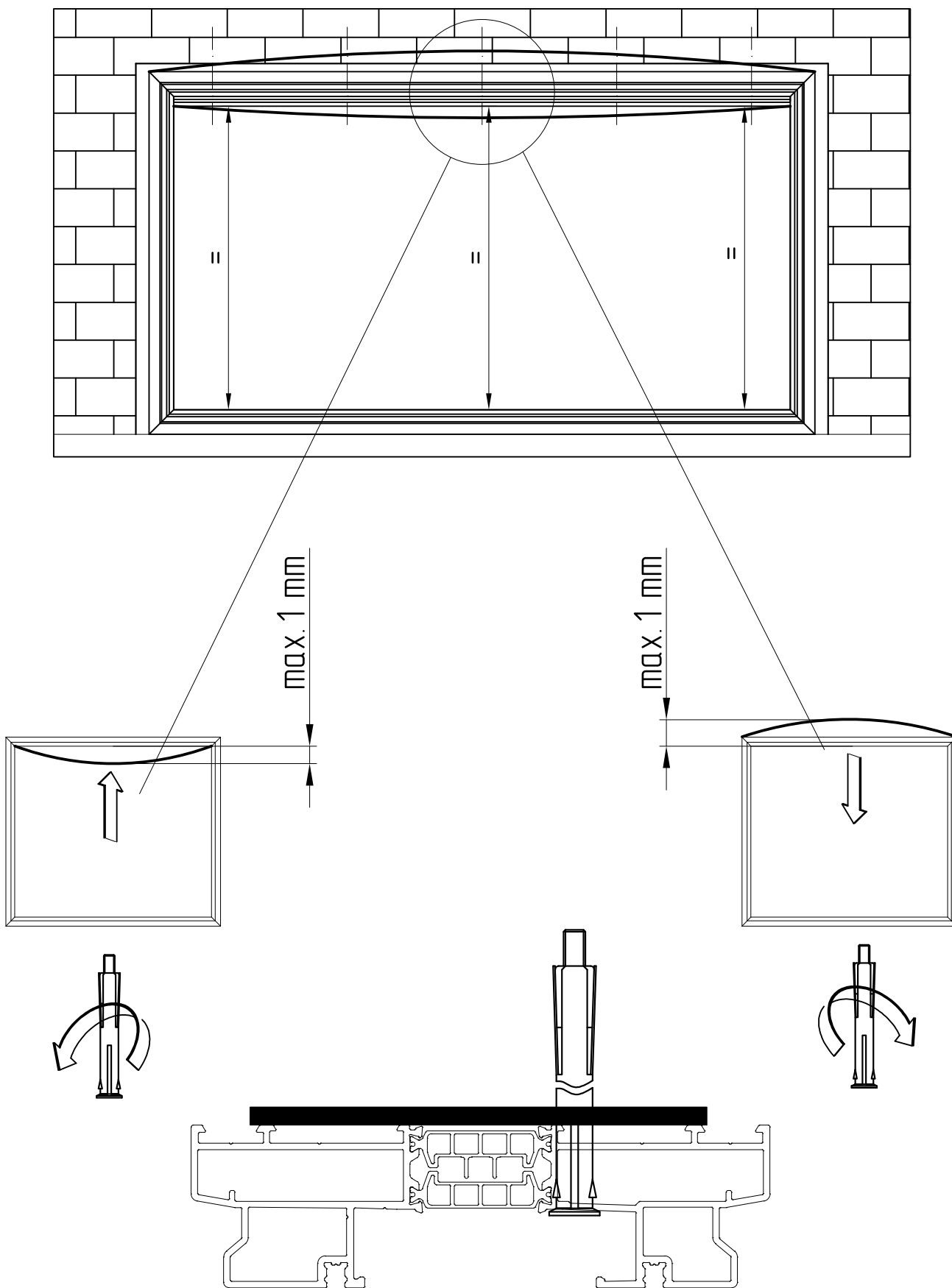

Mounting instructions of ALT SL160 (Continuation)

5

The sealing contour as well as the set components (SL160.0916) should be checked before the sash installation. In case of having the door with the fixed sash, try to install it as close as possible to the end ledge profile for further avoiding of the SL160.0915 collar shifting. The sash should be slightly uplifted while shifting.

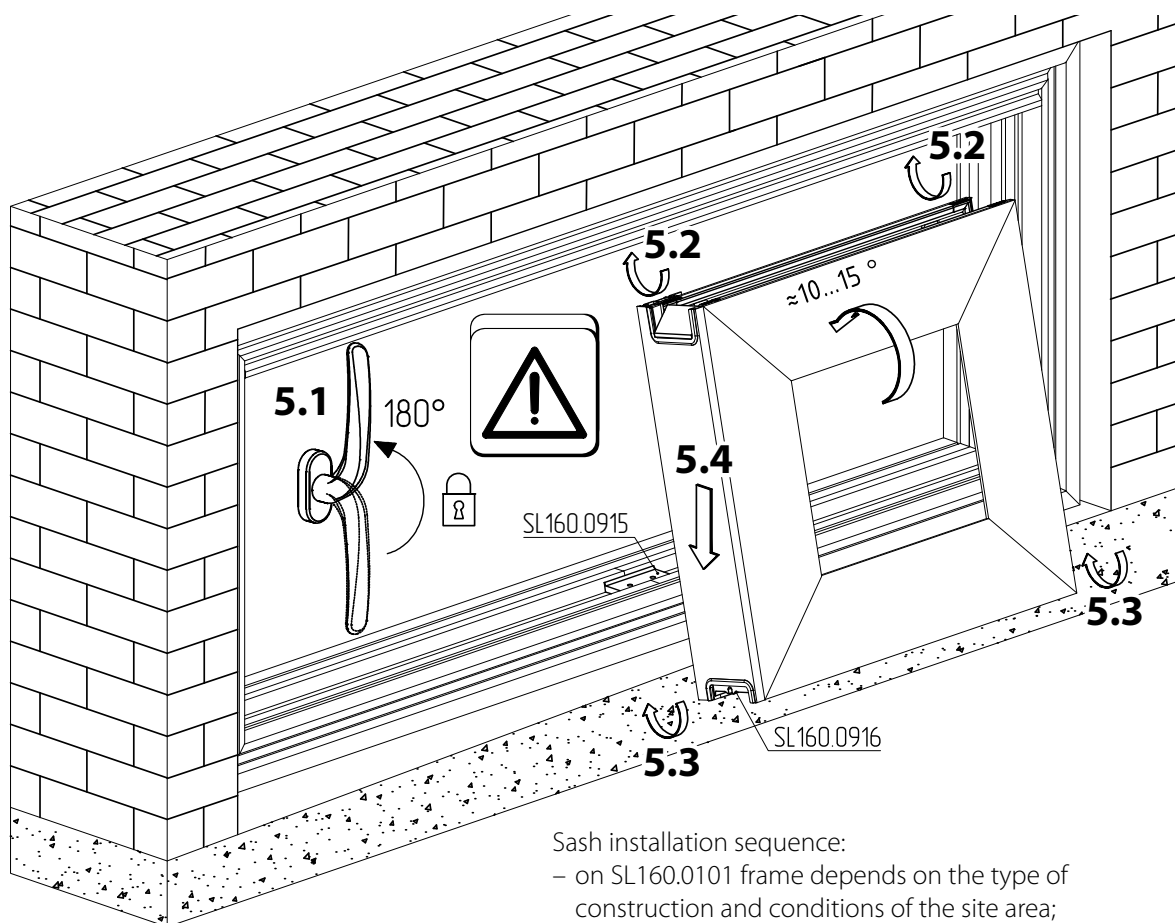

Sash installation sequence:

- on SL160.0101 frame depends on the type of construction and conditions of the site area;
- on SL160.0102 frame—from the outside;
- on SL160.0103 frame—from the inside.

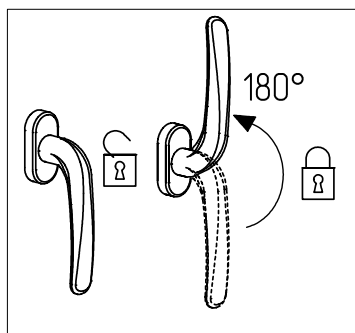

The sashes should move smoothly, without jerks and jams. Size 16 ± 1 need to be controlled after installation of the sash.

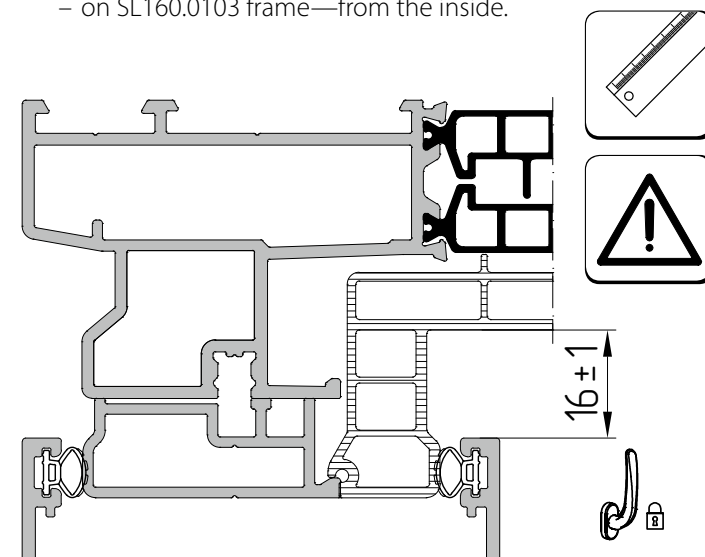

Mounting instructions of ALT SL160 (Continuation)

6

The additional elements should be installed in accordance with the technical manual guidance.

Installation of the locking elements

Tun	A1, mm	A2, mm	B1, mm	B2, mm	C1, mm	C2, mm
Gr. 180	588	612	988	1012	-	-
Gr. 210	738	762	1188	1212	1588	1612
Gr. 240					1888	1912
Gr. 270					2188	2212

Installation of the decorative elements



Microventilation hook is always installed from the bottom side.

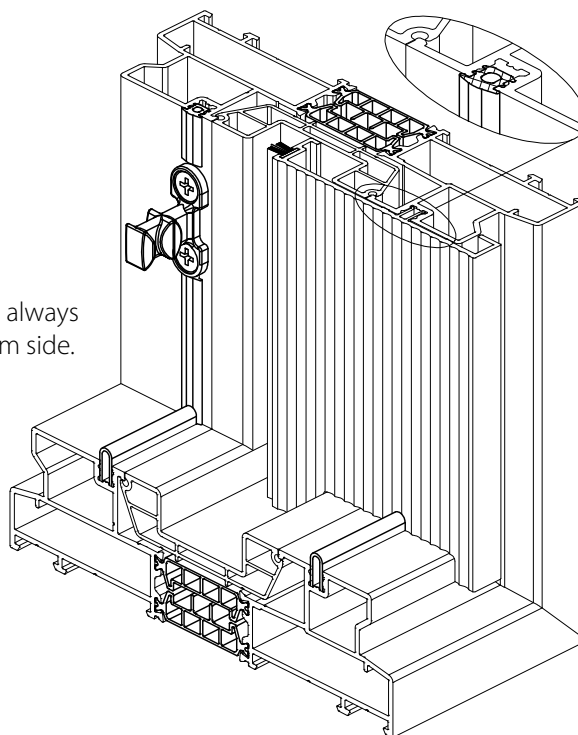

The dimensions should be measured from the top side of the AYPC.SL160.1950 guiding rail.

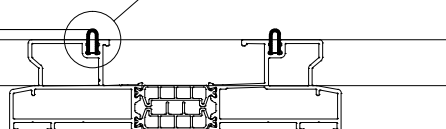
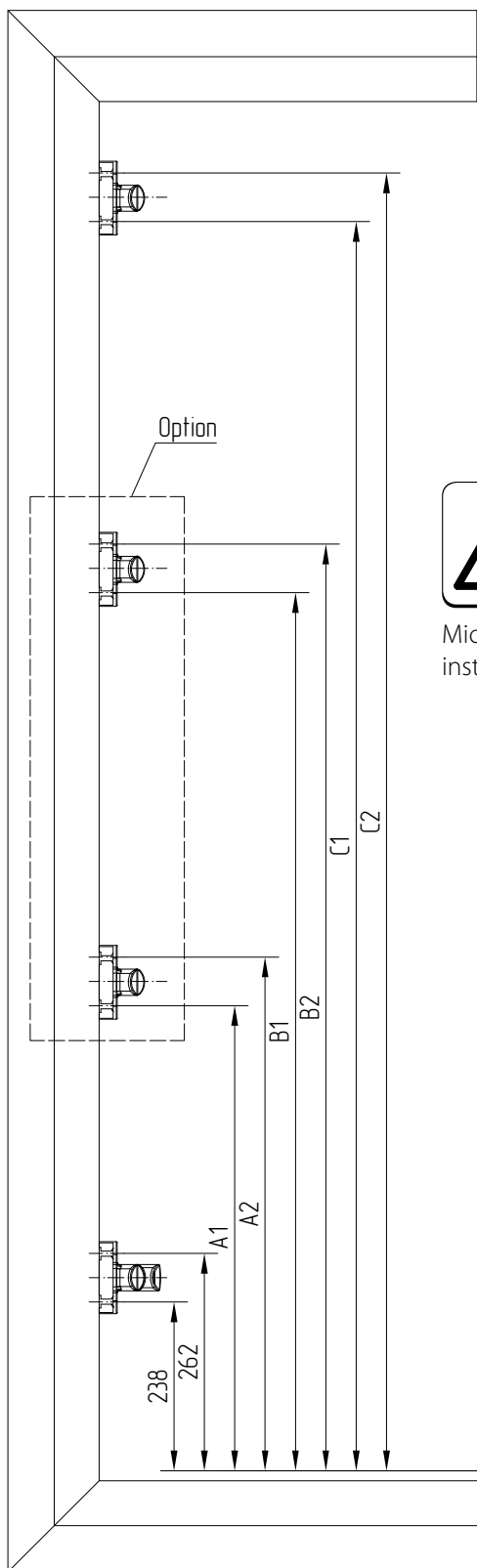
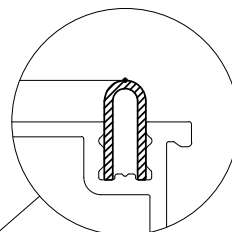

Mounting instructions of ALT SL160 (Continuation)

The stop kit installation

187480 (white) kit, 187477 (black) kit

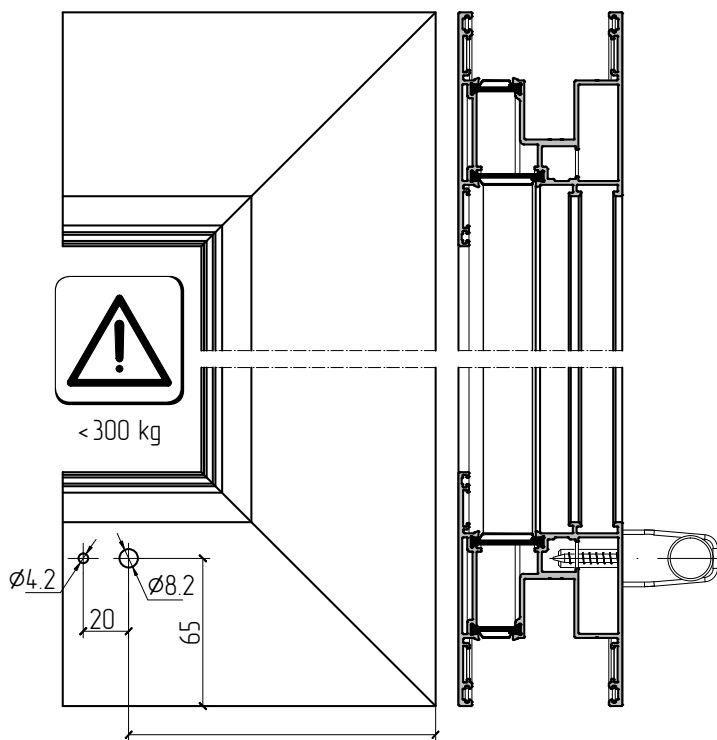
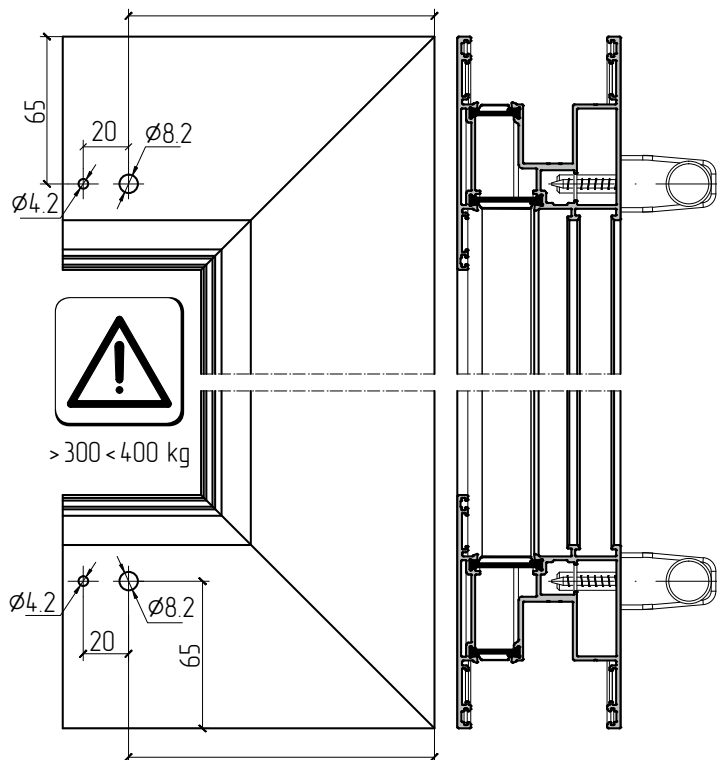

For service issues contact door installer:

Name: _____

Tel: _____

E-mail: _____

